

# **Service Guide**

## **HP 8590 Series Analyzers Assembly-Level Repair**



**HP Part No. 08590-90300    Supersedes 5963-2950**  
**Printed in USA    July 1998**

**Notice.**

The information contained in this document is subject to change without notice.

Hewlett-Packard makes no warranty of any kind with regard to this material, including but not limited to, the implied warranties of merchantability and fitness for a particular purpose. Hewlett-Packard shall not be liable for errors contained herein or for incidental or consequential damages in connection with the furnishing, performance, or use of this material.

---

## **Certification**

Hewlett-Packard Company certifies that this product met its published specifications at the time of shipment from the factory. Hewlett-Packard further certifies that its calibration measurements are traceable to the United States National Institute of Standards and Technology, to the extent allowed by the Institute's calibration facility, and to the calibration facilities of other International Standards Organization members.

## **Regulatory Information**

The regulatory information is located in the calibration guide for your analyzer.

---

## **Warranty**

This Hewlett-Packard instrument product is warranted against defects in material and workmanship for a period of one year from date of shipment. During the warranty period, Hewlett-Packard Company will, at its option, either repair or replace products which prove to be defective.

For warranty service or repair, this product must be returned to a service facility designated by Hewlett-Packard. Buyer shall prepay shipping charges to Hewlett-Packard and Hewlett-Packard shall pay shipping charges to return the product to Buyer. However, Buyer shall pay all shipping charges, duties, and taxes for products returned to Hewlett-Packard from another country.

Hewlett-Packard warrants that its software and firmware designated by Hewlett-Packard for use with an instrument will execute its programming instructions when properly installed on that instrument. Hewlett-Packard does not warrant that the operation of the instrument, or software, or firmware will be uninterrupted or error-free.

### **LIMITATION OF WARRANTY**

The foregoing warranty shall not apply to defects resulting from improper or inadequate maintenance by Buyer, Buyer-supplied software or interfacing, unauthorized modification or misuse, operation outside of the environmental specifications for the product, or improper site preparation or maintenance.

**NO OTHER WARRANTY IS EXPRESSED OR IMPLIED. HEWLETT-PACKARD SPECIFICALLY DISCLAIMS THE IMPLIED WARRANTIES OF MERCHANTABILITY AND FITNESS FOR A PARTICULAR PURPOSE.**

### **EXCLUSIVE REMEDIES**

**THE REMEDIES PROVIDED HEREIN ARE BUYER'S SOLE AND EXCLUSIVE REMEDIES. HEWLETT-PACKARD SHALL NOT BE LIABLE FOR ANY DIRECT, INDIRECT, SPECIAL, INCIDENTAL, OR CONSEQUENTIAL DAMAGES, WHETHER BASED ON CONTRACT, TORT, OR ANY OTHER LEGAL THEORY.**

---

## Assistance

*Product maintenance agreements and other customer assistance agreements are available for Hewlett-Packard products.*

*For any assistance, contact your nearest Hewlett-Packard Sales and Service Office.*

---

## Safety Notes

The following safety notes are used throughout this manual. Familiarize yourself with each of the notes and its meaning before operating this instrument.

---

**Warning**      **Warning denotes a hazard. It calls attention to a procedure which, if not correctly performed or adhered to, could result in injury or loss of life. Do not proceed beyond a warning note until the indicated conditions are fully understood and met.**

---

**Warning**      **These servicing instructions are for use by qualified personnel only. To avoid electrical shock, do not perform any servicing unless you are qualified to do so.**

---

**Warning**      **The power cord is connected to internal capacitors that may remain live for 10 seconds after disconnecting the plug from its power supply.**

---

**Caution**      **Caution denotes a hazard. It calls attention to a procedure that, if not correctly performed or adhered to, could result in damage to or destruction of the instrument. Do not proceed beyond a caution sign until the indicated conditions are fully understood and met.**

---



The instruction documentation symbol. The product is marked with this symbol when it is necessary for the user to refer to the instructions in the documentation.



The CE mark is a registered trademark of the European Community. (If accompanied by a year, it is when the design was proven.)



The CSA mark is a registered trademark of the Canadian Standards Association.



This is a symbol of an Industrial Scientific and Medical Group 1 Class A product.



---

## General Safety Considerations

---

**Warning** This is a Safety Class I product (provided with a protective earthing ground incorporated in the power cord). The mains plug shall only be inserted in a socket outlet provided with a protective earth contact. Any interruption of the protective conductor, inside or outside the instrument, is likely to make the instrument dangerous. Intentional interruption is prohibited.

---

**Warning** The opening of covers or removal of parts is likely to expose dangerous voltages. Disconnect the instrument from all voltage sources while it is being opened.

---

**Warning** The detachable power cord is the instrument disconnect device. It disconnects the mains circuits from the mains supply before other parts of the instrument. The front panel switch is only a standby switch and is not a LINE switch (disconnect device).

---

**Warning** These servicing instructions are for use by qualified personnel only. To avoid electrical shock, do not perform any service unless you are qualified to do so.

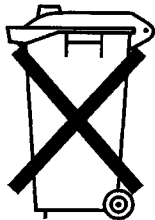
---

**Warning** The power cord is connected to internal capacitors that may remain live for 10 seconds after disconnecting the plug from its power supply.

---

**Warning** There is a danger of explosion if the battery is incorrectly replaced. Replace only with the same or equivalent type recommended. Discard used batteries according to manufacture's instructions.

---



DO NOT THROW BATTERIES AWAY BUT  
COLLECT AS SMALL CHEMICAL WASTE.

sk780a

---

**Warning** For continued protection against fire hazard, replace fuse only with same type and ratings, (type 5A/250V). The use of other fuses or materials is prohibited.

---

**Caution** Before switching on this instrument, make sure that the line voltage selector switch is set to the voltage of the power supply and the correct fuse is installed.

---

---

## How to Use This Guide

### This guide uses the following conventions.

- Front-Panel Key** This represents a key physically located on the instrument front panel.
- Softkey** This indicates a “softkey,” a key whose label is determined by the instrument’s firmware. Softkeys are located on the display bezel.
- Screen Text** This indicates text displayed on the instrument screen.

---

## HP 8590 E-Series and L-Series Spectrum Analyzer Documentation Description

**The following guides are shipped with your HP 8590 E-Series or L-Series spectrum analyzer.**

*HP 8590 E-Series Spectrum Analyzers and HP 8591C Cable TV Analyzer Calibration Guide*

- Tells you how to test your analyzer to determine if the analyzer meets its specifications.

*HP 8590 E-Series and L-Series Spectrum Analyzers User's Guide*

- Tells you how to make measurements with your analyzer.
- Describes the analyzer features.
- Tells you what to do in case of a failure.

*HP 8590 E-Series and L-Series Spectrum Analyzers Quick Reference Guide*

- Describes how to make a simple measurement with your analyzer.
- Briefly describes the analyzer functions.
- Lists all the programming commands.

---

## HP 8591C Cable TV Analyzer Documentation Description

**The following guides are shipped with your cable TV analyzer.**

*HP 8590 E-Series Spectrum Analyzers and HP 8591C Cable TV Analyzer Calibration Guide*

- Tells you how to test your analyzer to determine if the analyzer meets its specifications.

*HP 8591C Cable TV Analyzer User's Guides*

*Cable TV Measurements*

- Tells you how to make cable TV measurements with your analyzer.
- Describes the cable TV analyzer mode features.

*Spectrum Analyzer Reference*

- Tells you how to make measurements using the spectrum analyzer mode.
- Describes the spectrum analyzer mode features.
- Tells you what to do in case of a failure.

*HP 8591C Cable TV Analyzer Getting Started and Quick Reference Guide*

- Describes how to make a simple measurement with your analyzer.
- Briefly describes the cable TV and spectrum analyzer functions.
- Provides a quick reference for cable TV and spectrum analyzer softkeys.

*HP 8590 E-Series and L-Series Spectrum Analyzers, and HP 8591C Cable TV Analyzer Programmer's Guide*

- Describes analyzer operation via a remote controller (computer) for Parallel/RS-232 or Parallel/HPIB interface. This manual is provided when ordering either Option 041, Option 043, or HP 8591C.

## Documentation Options

### Option 041 or 043: Programmer's Guide

*HP 8590 E-Series and L-Series Spectrum Analyzers, and HP 8591C Cable TV Analyzer Programmer's Guide*

- Describes analyzer operation via a remote controller (computer) for Parallel/RS-232 or Parallel/HPIB interface.

### Option 910: Additional User's Documentation

Provides an additional copy of the user's guides, the calibration guide, and the quick reference guide.

### Option 915: Service Guide and Component-Level Information

Describes troubleshooting and repair of the analyzer.

Option 915 consists of two manuals:

*HP 8590 Series Analyzers Assembly-Level Repair Service Guide*

- Describes adjustment and assembly level repair of the analyzer.

*HP 8590 Series Analyzers Component-Level Repair Service Guide*

- Provides information for component-level repair of the analyzer.

---

## HP 8594Q QAM analyzer Documentation Description

**The following guides are shipped with your QAM analyzer.**

*HP 8590 Series Analyzers Calibration Guide*

- Tells you how to test your analyzer to determine if the analyzer meets its specifications.

*HP 8594Q QAM Analyzer User's Guides*

*Option 190/195 DVB-C/Data Measurements*

- Tells you how to make QAM measurements with your analyzer.
- Describes the QAM analyzer mode features.

*Spectrum Analyzer Reference*

- Tells you how to make measurements using the spectrum analyzer mode.
- Describes the spectrum analyzer mode features.
- Tells you what to do in case of a failure.

*HP 8594Q Option 190/195 DVB-C/Data Measurement QAM Analyzer Getting Started and Quick Reference Guide*

- Provides a quick reference for QAM and spectrum analyzer softkeys.

## Documentation Options

### Option 041 or 043: Programmer's Guide

*HP 8590 E-Series and L-Series Spectrum Analyzers, and HP 8591C Cable TV Analyzer Programmer's Guide*

- Describes analyzer operation via a remote controller (computer) for Parallel/RS-232 or Parallel/HPIB interface.

### Option 910: Additional User's Documentation

Provides an additional copy of the user's guides, the calibration guide, and the quick reference guide.

### Option 915: Service Guide and Component-Level Information

Describes troubleshooting and repair of the analyzer.

Option 915 consists of two manuals:

*HP 8590 Series Analyzers Assembly-Level Repair Service Guide*

- Describes adjustment and assembly level repair of the analyzer.

*HP 8590 Series Analyzers Component-Level Repair Service Guide*

- Provides information for component-level repair of the analyzer.

---

## How to Order Guides

Each of the guides listed above can be ordered individually. To order, contact your local HP Sales and Service Office.

# Contents

---

## 1. Introduction

Service Guide Organization . . . . .	1-2
Analyzer Description . . . . .	1-3
Firmware Revision Date . . . . .	1-4
Firmware Upgrade Kit Ordering Information . . . . .	1-4
Safety Considerations . . . . .	1-5
Reliability Considerations . . . . .	1-6
Analyzer Input Protection . . . . .	1-6
Protection from Electrostatic Discharge . . . . .	1-8
Handling of Electronic Components and ESD . . . . .	1-9
Test Equipment Usage and ESD . . . . .	1-9
For Additional Information about ESD . . . . .	1-9

## 2. Making Adjustments

Safety . . . . .	2-2
Before You Start . . . . .	2-3
Test equipment you will need . . . . .	2-3
If there are abnormal indications during adjustment . . . . .	2-3
Periodically verifying calibration . . . . .	2-3
Standard-value replacement components . . . . .	2-3
If you replace or repair an assembly . . . . .	2-3
1a. Display (with four access holes in top of shield) . . . . .	2-8
1b. Display (with eight access holes in top of shield) . . . . .	2-11
2. Sampler Match . . . . .	2-16
3. 10 MHz Reference . . . . .	2-18
4. 10 MHz Precision Frequency Reference . . . . .	2-20
5. Crystal and LC Bandwidth Filter . . . . .	2-23
6. Cal Attenuator Error . . . . .	2-30
7. Log and Linear Amplifier . . . . .	2-34
8. CAL FREQ Adjustment Routine . . . . .	2-38
9. CAL AMPTD Adjustment Routine . . . . .	2-40
10. CAL YTF Adjustment Routine . . . . .	2-42
11. CAL MXR Adjustment Routine . . . . .	2-46
12. Second Converter . . . . .	2-48
13. Third Converter and Second IF Bandpass . . . . .	2-53
14. Comb Generator . . . . .	2-58
15. Frequency Response of the HP 8590L, HP 8591C, and HP 8591E . . . . .	2-62
16. Frequency Response of the HP 8592L/94L, HP 8593E/94E/95E/96E, and HP 8594Q . . . . .	2-71
17. Time and Date . . . . .	2-86
18. Modulator Offset and Gain for Option 010 or 011 . . . . .	2-87
19. Entering External ALC Correction Constants for Option 010 or 011 . . . . .	2-90
20. Checking the External ALC for Option 010 or 011 . . . . .	2-91
21. Correcting for External ALC Error for Option 010 or 011 . . . . .	2-94
22. First LO Distribution Amplifier for Option 009 or 010 . . . . .	2-97
23. BITG Power Level for Option 010 . . . . .	2-99

24. Tracking Oscillator for Option 010 . . . . .	2-102
25. Checking the Absolute Amplitude Accuracy for Option 050 . . . . .	2-106
26. Correcting for Absolute Amplitude Accuracy for Option 050 . . . . .	2-111
27. Checking the Absolute Amplitude Accuracy for Option 051 . . . . .	2-113
Equipment required . . . . .	2-113
Additional Equipment for Option 026 . . . . .	2-113
Procedure . . . . .	2-114
Log Fidelity . . . . .	2-114
Frequency Range 810 MHz to 956 MHz . . . . .	2-115
Frequency Response Input Attenuator 10 dB . . . . .	2-115
Frequency Response Input Attenuator 20 dB . . . . .	2-115
Frequency Response Input Attenuator 30 dB . . . . .	2-116
Frequency Response Input Attenuator 40 dB . . . . .	2-117
Frequency Range 1429 MHz to 1501 MHz . . . . .	2-118
Frequency Response Input Attenuator 10 dB . . . . .	2-118
Frequency Response Input Attenuator 20 dB . . . . .	2-118
Frequency Response Input Attenuator 30 dB . . . . .	2-119
Frequency Response Input Attenuator 40 dB . . . . .	2-120
28. Correcting for Absolute Amplitude Accuracy for Option 051 . . . . .	2-121
Frequency Range 810 MHz to 956 MHz . . . . .	2-121
Frequency Range 1429 MHz to 1501 MHz . . . . .	2-123

### 3. Backing Up and Reloading Correction Constants

Before You Start . . . . .	3-1
Backing Up Analyzer Correction Constants . . . . .	3-2
Retrieve the timebase and flatness-correction constants . . . . .	3-2
Retrieve the A12 step-gain and CALTGX correction constants . . . . .	3-3
Analyzer Initialization . . . . .	3-4
Firmware startup sequence . . . . .	3-4
Set the default configuration . . . . .	3-5
Reset the power-on units . . . . .	3-5
Reloading the Correction Constants . . . . .	3-6
Reload the timebase-correction constant . . . . .	3-6
Reload the flatness-correction constants . . . . .	3-6
Reload the A12 step-gain-correction constants . . . . .	3-7
Reload the differential phase calibration constant . . . . .	3-7
Instrument Calibration after Reloading the Correction Constants . . . . .	3-8

### 4. Troubleshooting the Analyzer

Before You Start . . . . .	4-1
Service equipment you will need . . . . .	4-1
Replacement assemblies . . . . .	4-2
After an analyzer repair . . . . .	4-2
Problems at Instrument Power-Up . . . . .	4-3
Troubleshooting an Inoperative Analyzer . . . . .	4-5
Step 1. Check the Analyzer Setup . . . . .	4-5
Step 2. Check the Power Supply . . . . .	4-5
If the line fuse has blown . . . . .	4-7
If the fan is not operating . . . . .	4-7
If all the A8 power-supply LEDs are off . . . . .	4-8
If individual A8 power-supply LEDs are off . . . . .	4-9
If all the A8 power-supply LEDs are on . . . . .	4-9
If Using Defaults <N> is displayed . . . . .	4-9
Troubleshooting the A2 Display Assembly . . . . .	4-10
If the display has an intensity problem . . . . .	4-11

- If the display is blank . . . . . 4-11
- Isolating an RF, LO, IF, or Video Problem . . . . . 4-15
  - Procedure for Isolating an RF, LO, IF, or Video Failure . . . . . 4-15
  - If there is only a horizontal trace with no signal or noise floor present . . . . . 4-16
  - If the analyzer displays a low signal level . . . . . 4-17
  - If the analyzer displays a high noise floor . . . . . 4-17
  - If the displayed signal amplitude appears too high . . . . . 4-18
  - If the displayed signal is distorted . . . . . 4-18
  - If the signal is off frequency . . . . . 4-19
  - If the signal is off frequency in spans <10 MHz only . . . . . 4-19
  - If the signal displays in low band only . . . . . 4-19
- Using the Internal Service-Diagnostic Routines . . . . . 4-20
  - If a flat line appears at midscreen . . . . . 4-20
  - If a service-diagnostic routine fails . . . . . 4-20
  - Verify the displayed calibration data . . . . . 4-21
  - Verify the 2 V reference detector . . . . . 4-22
  - Verify the ground reference detector . . . . . 4-23
  - Verify the main coil driver . . . . . 4-24
  - Verify the FM coil driver . . . . . 4-25
  - Verify the FM coil driver for spans >10 MHz . . . . . 4-26
  - Verify the sweep ramp . . . . . 4-27
  - Verify the 10 V reference detector . . . . . 4-28
  - Verify the –10 V reference detector . . . . . 4-29
  - Verify the YTF driver . . . . . 4-30
- Troubleshooting the A16 Processor/Video Board Assembly . . . . . 4-31
  - If a signal cannot be displayed . . . . . 4-31
  - If the analyzer does not respond (locked up) . . . . . 4-31
  - Perform a free-run check . . . . . 4-32

**5. Troubleshooting the IF Section**

- Before You Start . . . . . 5-1
  - Service equipment you will need . . . . . 5-2
  - After an analyzer repair . . . . . 5-2
- IF Section Information . . . . . 5-2
- IF Power-Level Measurement . . . . . 5-3
  - To set up the instrument for an IF power-level measurement . . . . . 5-3
    - To check the gains for the IF assemblies . . . . . 5-3
  - To measure the IF signal from the A9 third converter . . . . . 5-4
  - To inject a signal at the output of the A11 bandwidth filter assembly . . . . . 5-4
  - To inject a signal at the output of the A13 bandwidth filter assembly . . . . . 5-5
  - To check bandwidth control lines for the A11/A13 bandwidth filter assemblies . . . . . 5-6
  - To check IF section gain control . . . . . 5-7
    - Control lines for the A12 amplitude control assembly . . . . . 5-9
    - To check linear gain control lines for the A14 log amplifier . . . . . 5-10
- Troubleshooting the A15 Motherboard Assembly . . . . . 5-11



<b>6. Troubleshooting the RF Section</b>	
Before You Start . . . . .	6-1
Service equipment you will need . . . . .	6-2
After an analyzer repair . . . . .	6-2
<b>6a. HP 8590L, HP 8591C, and HP 8591E</b>	
Making RF Power-Level Measurements . . . . .	6a-1
Connector Pin-Out Information . . . . .	6a-2
To check control of the A3 input attenuator . . . . .	6a-3
<b>6b. HP 8592L/94L, HP 8594Q, and HP 8593E/94E/95E/96E</b>	
Making RF Power-Level Measurements . . . . .	6b-1
Connector Pin-Out Information . . . . .	6b-3
To check control of the A3A5 input attenuator . . . . .	6b-5
<b>7. Replacing Major Assemblies</b>	
Introduction . . . . .	7-1
Before You Start . . . . .	7-1
Service equipment you will need . . . . .	7-1
After an analyzer repair . . . . .	7-2
Removal and Replacement Procedures in this Chapter . . . . .	7-2
Instrument Cover . . . . .	7-3
A1 Front-Frame Assembly . . . . .	7-4
A1A1 Keyboard/Front-Panel Keys . . . . .	7-7
A2 Display . . . . .	7-8
RF Assembly . . . . .	7-13
A3 Front-End Assembly . . . . .	7-16
A7 Analog Interface Assembly . . . . .	7-22
A8 Power Supply . . . . .	7-25
A15 Motherboard and IF Extrusion . . . . .	7-27
A16 Processor/Video Board and A16A1 Memory Board Assembly . . . . .	7-32
A16 Processor/Video Board Firmware ROMs . . . . .	7-36
A16A1BT1 Battery . . . . .	7-38
A17 Memory Card Reader Assembly . . . . .	7-40
A25 Counter-Lock Assembly . . . . .	7-42
B1 Fan . . . . .	7-44
Rear-Frame Assembly . . . . .	7-46
<b>8. Contacting Hewlett-Packard</b>	
Check the Basics . . . . .	8-2
Calling HP Sales and Service Offices . . . . .	8-3
Instrument serial numbers . . . . .	8-3
Before calling Hewlett-Packard . . . . .	8-4
HP sales and service offices . . . . .	8-4
Returning Your Analyzer for Service . . . . .	8-6
Package the analyzer for shipment . . . . .	8-6

## 9. Assembly Descriptions and Block Diagrams

RF and LO Section for HP 8590L, HP 8591E, and HP 8591C Spectrum Analyzers . . . . .	9-2
J1 Input Connector . . . . .	9-2
A3 Input Attenuator . . . . .	9-2
A4 First Converter . . . . .	9-2
FL1 Low-Pass Filter and AT1 Isolator . . . . .	9-2
A5 Second Converter . . . . .	9-2
A9 Third Converter . . . . .	9-3
10 MHz Frequency Reference . . . . .	9-3
A25 Counterlock . . . . .	9-4
A25A1 Sampler . . . . .	9-4
A6 YIG Tuned Oscillator (YTO) . . . . .	9-5
A7 Analog Interface . . . . .	9-5
RF and LO Section for HP 8592L, HP 8593E, HP 8594E, HP 8594L, HP 8594Q, HP 8595E, and HP 8596E Analyzers . . . . .	9-6
LO Section for the HP 8593E, HP 8594E, HP 8594L, HP 8594Q, HP 8595E, and HP 8596E Analyzers . . . . .	9-7
A9 Third Converter Assembly . . . . .	9-8
A25 Counterlock Assembly . . . . .	9-9
A3A14 First LO Distribution Amplifier (LODA) for Option 009 or 010 . . . . .	9-10
A3A15 Tracking Generator for Option 010 . . . . .	9-10
Tracking Oscillator . . . . .	9-11
Upconverter . . . . .	9-11
Pentupler . . . . .	9-11
Modulator . . . . .	9-11
Coupler . . . . .	9-11
Output Mixer . . . . .	9-11
Output Amplifier . . . . .	9-11
Bias Board . . . . .	9-11
IF Section . . . . .	9-12
A11 Bandwidth Filter . . . . .	9-12
A12 Amplitude Control . . . . .	9-12
A13 Bandwidth Filter . . . . .	9-13
A14 Log Amplifier . . . . .	9-13
A16 Processor/Video and A16A1 Memory Boards . . . . .	9-14
A7 Analog Interface . . . . .	9-15
A8 Power Supply . . . . .	9-16
A130 Narrow Bandwidth . . . . .	9-16

## 10. Analyzer Options and Block Diagrams

Option Descriptions . . . . .	10-4
75 $\Omega$ Input Impedance (Option 001) . . . . .	10-4
Memory Card Reader (Option 003) . . . . .	10-4
Precision Frequency Reference (Option 004) . . . . .	10-4
LO and Sweep+Tune Outputs on Rear Panel (Option 009) . . . . .	10-4
Tracking Generator (Option 010 and Option 011) . . . . .	10-4
Protective Tan Operating/Carrying Case with Shoulder Strap (Option 015) . . . . .	10-5
Protective Yellow Operating/Carrying Case with Shoulder Strap (Option 016) . . . . .	10-5
HP-IB and Parallel Interface (Option 041) . . . . .	10-5
RS-232 and Parallel Interface (Option 043) . . . . .	10-5
Frequency Extension to 26.5 GHz with APC-3.5 Connector (Option 026) . . . . .	10-6
Frequency Extension to 26.5 GHz with N-Type Connector (Option 027) . . . . .	10-6
Front Panel Protective Cover (Option 040) . . . . .	10-6
Protective Soft Carrying Case/Back Pack (Option 042) . . . . .	10-6
Improved Amplitude Accuracy for NADC bands (Option 050) . . . . .	10-6

Improved Amplitude Accuracy for PDC bands (Option 051) . . . . .	10-6
Improved Amplitude Accuracy for PHS (Option 052) . . . . .	10-7
Improved Amplitude Accuracy for CDMA (Option 053) . . . . .	10-7
Fast Time Domain Sweeps (Option 101) . . . . .	10-7
AM/FM Demodulator with Speaker and TV Sync Trigger Circuitry (Option 102)	10-7
Quasi-Peak Detector and AM/FM Demodulator With Speaker (Option 103) . . . .	10-7
Time-Gated Spectrum Analysis (Option 105) . . . . .	10-8
TV Receiver/Video Tester (Option 107) . . . . .	10-8
CT2 Demodulator (Option 110) . . . . .	10-8
Group Delay and Amplitude Flatness (Option 111) . . . . .	10-8
DECT Demodulator (Option 112) . . . . .	10-8
Noise Figure (Option 119) . . . . .	10-8
Narrow Resolution Bandwidths (Option 130) . . . . .	10-9
Narrow Resolution Bandwidths and Precision Frequency Reference (Option 140)	10-9
DSP, Fast ADC and Digital Demodulator (Option 151) . . . . .	10-9
PDC/PHS/NADC/CDMA Firmware for Option 151 (Option 160) . . . . .	10-10
GSM/DCS1800 Firmware for Option 151 (Option 163) . . . . .	10-10
TV Picture Display (Option 180) . . . . .	10-10
DVB-C (Option 190) . . . . .	10-10
TV Sync Trigger Capability/Fast Time-Domain Sweeps and AM/FM Demodulator (Option 301) . . . . .	10-10
50Ω to 75Ω Matching Pad (Option 711) . . . . .	10-11
Reduced Frequency Accuracy (Option 713) . . . . .	10-11
Rack Mount Kit Without Handles (Option 908) . . . . .	10-11
Rack Mount Kit With Handles (Option 909) . . . . .	10-11
User's Guide and Calibration Guide (Option 910) . . . . .	10-11
Service Documentation (Option 915) . . . . .	10-11
Troubleshooting Analyzer Options . . . . .	10-12
Tracking Generator HP 8590L, HP 8591C, and HP 8591E Option 010, 011 . . . . .	10-12
Tracking Generator HP 8593E, 8594E, 8595E, 8596E Option 010 . . . . .	10-14
If the output goes unlevelled (TG UNLVL message displayed) . . . . .	10-14
To check excessive residual FM . . . . .	10-16
If flatness is out of tolerance . . . . .	10-17
If vernier accuracy is out of tolerance . . . . .	10-18
If harmonic/spurious outputs are too high . . . . .	10-19
If power sweep is not functioning properly . . . . .	10-20
If there is no output power . . . . .	10-21
First LO Distribution Amplifier (LODA) HP 8593E, 8594E, 8594Q, 8595E, 8596E Option 009 . . . . .	10-22
DVB-C HP 8594Q QAM Analyzer Option 190 . . . . .	10-24
Troubleshooting Tree . . . . .	10-24
Option 190 DVB-C Connection Diagram . . . . .	10-32
Option 190 DVB-C Service Menus . . . . .	10-33

## 11. Major Assembly and Cable Locations

<b>12. Replaceable Parts</b>	
Ordering Information . . . . .	12-2
To order an assembly or mechanical part listed in this chapter: . . . . .	12-2
To order a part that is <i>not</i> listed in the replaceable parts lists: . . . . .	12-2
Direct Mail-Order System . . . . .	12-2
Direct Phone-Order System using (800) 227-8164 (U.S. Only) . . . . .	12-3
Regular Orders . . . . .	12-3
Hotline Orders . . . . .	12-3
Standard-Value Replacement Components . . . . .	12-8
Component-Level Information Packets . . . . .	12-27
Ordering CLIPs . . . . .	12-27
<b>13. Softkey Descriptions</b>	
Calibration, Service, and Diagnostic Softkey Functions . . . . .	13-1
[ <b>CAL</b> ] Softkey Organization . . . . .	13-1
Understanding Analyzer Passcodes . . . . .	13-4
-37 Hz Passcode . . . . .	13-4
-2001 Hz Passcode . . . . .	13-4
Entering a Passcode . . . . .	13-4
Understanding Analyzer Correction Data . . . . .	13-5
Self-Calibration Correction Factors . . . . .	13-5
Service-Calibration Correction Constants . . . . .	13-5
$\phi$ Lock ON OFF Phase Lock On/Off . . . . .	13-6
+10 V REF DETECTOR +10 V Reference Detector . . . . .	13-6
-10 V REF DETECTOR -10 V Reference Detector . . . . .	13-7
2v REF DETECTOR 2 V Reference Detector . . . . .	13-7
ALC TEST Automatic Level Control TEST . . . . .	13-7
Amp Cor Amplitude Correction . . . . .	13-8
ANALYZER GAINS Analyzer Gains . . . . .	13-8
AUXB Auxiliary B . . . . .	13-8
BINARY SPAN Binary Span . . . . .	13-9
[ <b>CAL</b> ] Calibration Key . . . . .	13-9
CAL AMPTD Calibrate Amplitude . . . . .	13-9
CAL FETCH Calibration Fetch . . . . .	13-11
CAL FREQ Calibrate Frequency . . . . .	13-12
CAL FREQ & AMPTD Calibrate Frequency and Amplitude . . . . .	13-14
CAL MXR Calibrate Mixer . . . . .	13-14
CAL STORE Calibration Store . . . . .	13-15
CAL TIMEBASE Calibrate Timebase . . . . .	13-16
CAL TRK GEN Calibrate Tracking Generator . . . . .	13-17
CAL YTF Calibrate YTF . . . . .	13-18
COARSE TUNE DAC Coarse Tune DAC . . . . .	13-19
CONF TEST Confidence Test . . . . .	13-19
CORRECT ON OFF Correction On/Off . . . . .	13-21
CRT HORZ POSITION CRT Horizontal Position . . . . .	13-22
CRT VERT POSITION CRT Vertical Position . . . . .	13-22

DACS DACs . . . . .	13-23
DEFAULT CAL DATA Default Calibration Data . . . . .	13-24
DISPLAY CAL DATA Display Calibration Data . . . . .	13-26
DROOP Droop . . . . .	13-29
EDIT FLATNESS Edit Flatness . . . . .	13-30
EXECUTE TITLE Execute Title . . . . .	13-31
EXIT Exit . . . . .	13-31
FINE TUNE DAC Fine Tune DAC . . . . .	13-31
FLATNESS DATA Flatness Data . . . . .	13-32
FM COIL DRIVE FM Coil Drive . . . . .	13-32
FM GAIN FM Gain . . . . .	13-33
FM OFFSET FM Offset . . . . .	13-35
FM SPAN FM Span . . . . .	13-36
FREQ DIAG Frequency Diagnostics . . . . .	13-37
FRQ DISC NORM OFF Frequency Discriminator Normal/Off . . . . .	13-39
GND REF DETECTOR Ground-Reference Detector . . . . .	13-39
IDNUM Identification Number . . . . .	13-39
INIT FLT Initialize Flatness . . . . .	13-40
INIT FLT 22 GHz Initialize Flatness 22 GHz . . . . .	13-41
INIT FLT 26.5 GHz Initialize Flatness 26.5 GHz . . . . .	13-41
MAIN COIL DR Main-Coil Drive . . . . .	13-42
MAIN SPAN Main Span . . . . .	13-43
MIXER BIAS DAC Mixer-Bias DAC . . . . .	13-43
PRESEL DAC Preselector DAC . . . . .	13-44
QP DET ON OFF Quasi-Peak Detector On/Off . . . . .	13-44
QP GAIN ON OFF Quasi-Peak GAIN On/Off . . . . .	13-44
QPD OFFSET Quasi-Peak Detector Offset . . . . .	13-45
QPD RST ON OFF Quasi-Peak Detector Reset On/Off . . . . .	13-45
SERVICE CAL Service Calibration . . . . .	13-45
SERVICE DIAG Service Diagnostics . . . . .	13-45
SET ATTN ERROR Set Attenuator Error . . . . .	13-46
STOR PWR ON UNITS Store Power-On Units . . . . .	13-47
STORE FLATNESS Store Flatness . . . . .	13-48
STP GAIN ZERO Step-Gain Zero . . . . .	13-48
SWEEP RAMP Sweep Ramp . . . . .	13-48
SWEEP TIME DAC Sweep-Time DAC . . . . .	13-49
VERIFY TIMEBASE Verify Timebase . . . . .	13-49
X FINE TUNE DAC Extra-Fine Tune DAC . . . . .	13-50
YTF DRIVER YTF Driver . . . . .	13-50
YTF TUNE COARSE YTF Tune Coarse . . . . .	13-51

YTF TUNE FINE YTF Tune Fine . . . . .	13-51
YTF SPAN YTF Span . . . . .	13-52

**14. Analyzer Messages**

Interpreting Analyzer Messages . . . . .	14-1
What's in This Chapter . . . . .	14-1
$\phi$ LOCK OFF (U) (H) . . . . .	14-2
Related Assemblies . . . . .	14-2
Troubleshooting Hints . . . . .	14-2
ADC-GND FAIL (H) . . . . .	14-2
Related Assemblies . . . . .	14-2
Troubleshooting Hints . . . . .	14-2
ADC-TIME FAIL (H) . . . . .	14-4
Related Assemblies . . . . .	14-4
Troubleshooting Hints . . . . .	14-4
ADC-2V FAIL (H) . . . . .	14-4
Related Assemblies . . . . .	14-4
Troubleshooting Hints . . . . .	14-4
CAL:_ _ _ (M) . . . . .	14-6
Troubleshooting Hints . . . . .	14-6
CAL:_ _ _ : done Press CAL STORE to save (M) . . . . .	14-6
CAL: cannot execute CALAMP enter: 0 dB PREAMP GAIN (U)(H) . . . . .	14-6
Troubleshooting Hints . . . . .	14-6
CAL: DATA NOT STORED CAL AMP NEEDED (U)(H) . . . . .	14-7
Related Assemblies . . . . .	14-7
Troubleshooting Hints . . . . .	14-7
CAL: FM SPAN SENS FAIL (H) . . . . .	14-7
Related Assemblies . . . . .	14-7
Troubleshooting Hints . . . . .	14-7
CAL: GAIN FAIL (H) . . . . .	14-8
Related Assemblies . . . . .	14-8
Troubleshooting Hints . . . . .	14-8
Cal harmonic >= 5.7 GHz NOT found (U)(H) . . . . .	14-8
Related Assemblies . . . . .	14-8
Troubleshooting Hints . . . . .	14-8
CAL: MAIN COIL SENSE FAIL (H) . . . . .	14-9
Related Assemblies . . . . .	14-9
Troubleshooting Hints . . . . .	14-9
CAL: NBW 200 Hz notch amp failed (H) . . . . .	14-9
Related Assemblies . . . . .	14-9
Troubleshooting Hints . . . . .	14-9
CAL: NBW 200 Hz notch failed (H) . . . . .	14-9
Related Assemblies . . . . .	14-9
Troubleshooting Hints . . . . .	14-9
CAL: NBW 200 Hz width failed (H) . . . . .	14-10
Related Assemblies . . . . .	14-10
Troubleshooting Hints . . . . .	14-10
CAL: NBW gain failed (H) . . . . .	14-10
Related Assemblies . . . . .	14-10
Troubleshooting Hints . . . . .	14-10
CAL: NBW width failed (H) . . . . .	14-10
Related Assemblies . . . . .	14-10
Troubleshooting Hints . . . . .	14-10
CAL: PASSCODE NEEDED (M) . . . . .	14-10

Troubleshooting Hints . . . . .	14-10
CAL: RES BW AMPL FAIL (H) . . . . .	14-11
Related Assemblies . . . . .	14-11
Troubleshooting Hints . . . . .	14-11
CAL SIGNAL NOT FOUND (U)(H) . . . . .	14-11
Related Assemblies . . . . .	14-11
Troubleshooting Hints . . . . .	14-11
CAL: SPAN SENS FAIL (H) . . . . .	14-12
Related Assemblies . . . . .	14-12
Troubleshooting Hints . . . . .	14-12
CAL: USING DEFAULT DATA (M) . . . . .	14-12
Troubleshooting Hints . . . . .	14-12
CAL YTF FAILED (U)(H) . . . . .	14-12
Related Assemblies . . . . .	14-12
Troubleshooting Hints . . . . .	14-12
CAL: ZERO FAIL (H) . . . . .	14-13
Related Assemblies . . . . .	14-13
Troubleshooting Hints . . . . .	14-13
Cannot engage phase lock with current CAL FREQ data (U) . . . . .	14-13
Related Assemblies . . . . .	14-13
Troubleshooting Hints . . . . .	14-13
Cannot reach N dB points (U) . . . . .	14-13
Related Assemblies . . . . .	14-13
Troubleshooting Hints . . . . .	14-13
Check trigger input (U) . . . . .	14-14
Related Assemblies . . . . .	14-14
Troubleshooting Hints . . . . .	14-14
Comb harmonic at _ _ _ GHz NOT found (U)(H) . . . . .	14-14
Related Assemblies . . . . .	14-14
Troubleshooting Hints . . . . .	14-14
COMB SIGNAL NOT FOUND (U)(H) . . . . .	14-15
Related Assemblies . . . . .	14-15
Troubleshooting Hints . . . . .	14-15
COMMAND ERROR:_ _ _ (U) . . . . .	14-16
Related Assemblies . . . . .	14-16
Troubleshooting Hints . . . . .	14-16
CONF TEST FAIL (U)(H) . . . . .	14-16
Troubleshooting Hints . . . . .	14-16
Factory DLP, not adaptable (U) . . . . .	14-16
FAIL: XXXX XXXXXXXXXXXX (H) . . . . .	14-16
The Four-Digit Failure Code . . . . .	14-17
The 10-Digit Failure Code . . . . .	14-18
Related Assemblies . . . . .	14-19
Troubleshooting Hints . . . . .	14-19
File type incompatible (U) . . . . .	14-20
FREQ UNCAL (U) (H) . . . . .	14-20
Related Assemblies . . . . .	14-20
Troubleshooting Hints . . . . .	14-20
Function not available in current Mode (U) . . . . .	14-20
Function not available with analog display (U) . . . . .	14-20
Gate card not calibrated (U)(H) . . . . .	14-21
Related Assemblies . . . . .	14-21
Troubleshooting Hints . . . . .	14-21
INTERNAL LOCKED (U) . . . . .	14-21
INVALID ACTDEF: _ _ _ (U) . . . . .	14-21

INVALID AMPCOR: FREQ (U) . . . . .	14-21
INVALID BLOCK FORMAT: IF STATEMENT (U) . . . . .	14-21
INVALID CARD (U) . . . . .	14-21
INVALID CARD: BAD MEDIA (U)(H) . . . . .	14-22
INVALID CARD: DATA ERROR (U)(H) . . . . .	14-22
INVALID CARD: DIRECTORY (U) . . . . .	14-22
INVALID CARD: NO CARD (U) . . . . .	14-22
INVALID CARD: TYPE (U) . . . . .	14-22
INVALID CHECKSUM: USTATE (U) . . . . .	14-22
INVALID COMPARE OPERATOR (U) . . . . .	14-22
INVALID DET: FM or TV option only (U) . . . . .	14-22
INVALID ENTER FORMAT (U) . . . . .	14-22
INVALID <file name> NOT FOUND (U) . . . . .	14-23
INVALID FILENAME _ _ _ (U) . . . . .	14-23
INVALID FILE: NO ROOM (U) . . . . .	14-23
INVALID HP-IB ADRS/OPERATION (U) . . . . .	14-23
Related Assemblies . . . . .	14-23
Troubleshooting Hints . . . . .	14-23
INVALID HP-IB OPERATION REN TRUE (U) . . . . .	14-23
Related Assemblies . . . . .	14-23
Troubleshooting Hints . . . . .	14-23
INVALID ITEM:_ _ _ (U) . . . . .	14-24
INVALID KEYLBL: _ _ _ (U) . . . . .	14-24
INVALID KEYNAME:_ _ _ (U) . . . . .	14-24
Related Assemblies . . . . .	14-24
Troubleshooting Hints . . . . .	14-24
INVALID OUTPUT FORMAT (U) . . . . .	14-24
INVALID RANGE: Stop < Start (U) . . . . .	14-24
INVALID REGISTER NUMBER (U) . . . . .	14-24
INVALID REPEAT MEM OVFL (U) . . . . .	14-24
INVALID REPEAT NEST LEVEL (U) . . . . .	14-24
INVALID RS-232 ADRS/OPERATION (U) . . . . .	14-25
Related Assemblies . . . . .	14-25
Troubleshooting Hints . . . . .	14-25
INVALID SAVE REG (U) . . . . .	14-25
INVALID SCRMOVE (H) . . . . .	14-25
Related Assemblies . . . . .	14-25
Troubleshooting Hints . . . . .	14-25
INVALID START INDEX (U) . . . . .	14-25
INVALID STOP INDEX (U) . . . . .	14-25
INVALID STORE DEST: _ _ _ (U) . . . . .	14-25
Memory Overflow: ERASE DLP MEM and reload (U) . . . . .	14-26
Related Assemblies . . . . .	14-26
Troubleshooting Hints . . . . .	14-26
INVALID TRACE: _ _ _ (U) . . . . .	14-26
INVALID TRACE NAME: _ _ _ (U) . . . . .	14-26
INVALID TRACENAME: _ _ _ (U) . . . . .	14-26
INVALID VALUE PARAMETER: _ _ _ (U) . . . . .	14-27
INVALID VARDEF: _ _ _ (U) . . . . .	14-27
INVALID WINDOW TYPE: _ _ _ (U) . . . . .	14-27
LOST SIGNAL (U) . . . . .	14-27
Related Assemblies . . . . .	14-27
Troubleshooting Hints . . . . .	14-27
LO UNLVL (U)(H) . . . . .	14-27
Related Assemblies . . . . .	14-27



Troubleshooting Hints . . . . .	14-27
Marker Count Reduce SPAN (U) . . . . .	14-28
Marker Count Widen RES BW (U) . . . . .	14-28
MEAS UNCAL (U) . . . . .	14-28
No card found (U) . . . . .	14-28
No points defined (U) . . . . .	14-28
MIXER BIAS CAL FAILED . . . . .	14-29
Related Assemblies . . . . .	14-29
Troubleshooting Hints . . . . .	14-29
OVEN COLD (M) . . . . .	14-30
Related Assemblies . . . . .	14-30
Troubleshooting Hints . . . . .	14-30
PARAMETER ERROR: _ _ _ (U) . . . . .	14-30
PASSCODE NEEDED (U) . . . . .	14-30
POS-PK FAIL (H) . . . . .	14-30
Related Assemblies . . . . .	14-30
Troubleshooting Hints . . . . .	14-30
REF UNLOCK (M)(H) . . . . .	14-31
Related Assemblies . . . . .	14-31
Troubleshooting Hints . . . . .	14-31
Require 1 signal > PEAK EXCURSION above THRESHOLD (U) . . . . .	14-32
Require 3 signals > PEAK EXCURSION above THRESHOLD (U) . . . . .	14-32
Require 4 signals > PEAK EXCURSION above THRESHOLD (U) . . . . .	14-32
Required option not installed (U) . . . . .	14-32
RES-BW NOISE FAIL (H) . . . . .	14-32
Related Assemblies . . . . .	14-32
Troubleshooting Hints . . . . .	14-32
RES-BW SHAPE FAIL (H) . . . . .	14-33
Related Assemblies . . . . .	14-33
Troubleshooting Hints . . . . .	14-33
RF PRESEL ERROR (H) . . . . .	14-34
Related Assemblies . . . . .	14-34
Troubleshooting Hints . . . . .	14-34
RF PRESEL TIMEOUT (H) . . . . .	14-34
Related Assemblies . . . . .	14-34
Troubleshooting Hints . . . . .	14-34
SAMPLE FAIL (H) . . . . .	14-34
Related Assemblies . . . . .	14-34
Troubleshooting Hints . . . . .	14-34
SETUP ERROR (U) . . . . .	14-35
SIGNAL CLIPPED (U) . . . . .	14-35
Signals do not fit expected % AM pattern (U) . . . . .	14-35
Signals do not fit expected TOI pattern (U) . . . . .	14-35
SMPLR UNLCK (U)(H) . . . . .	14-35
Related Assemblies . . . . .	14-35
Troubleshooting Hints . . . . .	14-35
SOFTKEY OVFL (U) . . . . .	14-35
SRQ _ _ _ (M) . . . . .	14-35
STEP GAIN/ATTEN FAIL (H) . . . . .	14-36
Related Assemblies . . . . .	14-36
Troubleshooting Hints . . . . .	14-36
Stop at marker not available with negative detection (U) . . . . .	14-36
SYMTAB EMPTY (U) . . . . .	14-36
Related Assemblies . . . . .	14-36
Troubleshooting Hints . . . . .	14-36

TABLE FULL (U)	14-37
TG SIGNAL NOT FOUND (U)	14-37
Description	14-37
Related Assemblies	14-37
Troubleshooting Hints	14-37
TG UNLVL (U)(H)	14-37
Related Assemblies	14-37
Troubleshooting Hints	14-37
Too many signals with valid N dB points (U)	14-38
Trace A is not available (U)	14-38
UNDF KEY (U)	14-38
USING DEFAULTS: _ _ _	14-38
Related Assemblies	14-38
Troubleshooting Hints	14-38
USING DEFAULTS self cal needed (U)	14-38
Verify gate trigger input is disconnected before CAL AMPTD (U)	14-38
VID-BW FAIL (H)	14-39
Related Assemblies	14-39
Troubleshooting Hints	14-39
Waiting for gate input ... (U)	14-39
Related Assemblies	14-39
Troubleshooting Hints	14-39
YTF is not available (U)	14-39

**15. Service Equipment and Tools**

Static-Safe Accessories	15-1
Recommended Test Equipment	15-2
Recommended Service Tools	15-3

**Index**

# Figures

---

1-1. Example of a Static-Safe Workstation . . . . .	1-8
2-1. Fine Focus Adjustment Location . . . . .	2-9
2-2. Coarse Focus Adjustment Location (rear view of display assembly) . . . . .	2-10
2-3. Focus Adjustment Location . . . . .	2-12
2-4. Display Adjustment Locations . . . . .	2-13
2-5. A25 Counter Lock Assembly Test Points . . . . .	2-17
2-6. 10 MHz Reference Adjustment Setup . . . . .	2-18
2-7. Precision Frequency Reference Setup . . . . .	2-20
2-8. Oven Reference Adjustment Location . . . . .	2-22
2-9. Crystal Symmetry and Centering . . . . .	2-24
2-10. Cal Attenuator Error Correction Setup . . . . .	2-30
2-11. Log and Linear Amplifier Adjustment Setup . . . . .	2-34
2-12. Log and Linear Amplifier Adjustment Location . . . . .	2-36
2-13. CAL FREQ Adjustment Routine Setup . . . . .	2-38
2-14. CAL AMPTD Adjustment Routine Setup . . . . .	2-40
2-15. CAL YTF Adjustment Setup . . . . .	2-42
2-16. CAL MXR Adjustment Setup . . . . .	2-46
2-17. Tripler Adjustment Setup . . . . .	2-49
2-18. Second Converter Adjustment Location . . . . .	2-49
2-19. Second Converter Bandpass Adjustment Setup . . . . .	2-50
2-20. Second Mixer Match Adjustment Setup . . . . .	2-51
2-21. Second Converter Bandpass Ripple Measurement . . . . .	2-52
2-22. Second IF Bandpass Filter Adjustment Setup . . . . .	2-54
2-23. LPF Characterization . . . . .	2-56
2-24. 300 MHz Calibrator Amplitude Accuracy Test Setup . . . . .	2-57
2-25. Comb Generator Adjustment Location . . . . .	2-59
2-26. Comb Generator Component Location . . . . .	2-60
2-27. System Characterization Test Setup for 75 $\Omega$ inputs . . . . .	2-63
2-28. Frequency Response Setup . . . . .	2-64
2-29. Frequency Response for 4 MHz Setup . . . . .	2-65
2-30. Frequency Response Setup . . . . .	2-72
2-31. External ALC Verification Adjustment . . . . .	2-92
2-32. External ALC Error Correction Adjustment . . . . .	2-95
2-33. First LO Distribution Amplifier Adjustment Setup . . . . .	2-97
2-34. BITG Power Level Adjustment Setup . . . . .	2-100
2-35. BITG Power Level Adjustment Locations . . . . .	2-100
2-36. Frequency Tracking Range Setup . . . . .	2-103
2-37. Tracking Oscillator Adjustment Setup . . . . .	2-104
2-38. Absolute Amplitude Accuracy Verification . . . . .	2-106
2-39. Absolute Amplitude Accuracy Verification . . . . .	2-113
4-1. A16 Power Supply Test Point Location . . . . .	4-5
4-2. A15J13 Connector-Pin Designation . . . . .	4-8
4-3. Detail of Power Supply Connector, A8J6 . . . . .	4-10
4-4. A16J8 Display Signal Output Pins . . . . .	4-12
4-5. A16J1 Connector-Pin Orientation . . . . .	4-14
4-6. Card-Cage Connector-Pin Orientation . . . . .	4-14

4-7.	2 V Reference Detector . . . . .	4-22
4-8.	Ground Reference Detector . . . . .	4-23
4-9.	Main Coil Driver Typical Display . . . . .	4-24
4-10.	FM Coil Driver with $\leq 10$ MHz Span . . . . .	4-25
4-11.	FM Coil Driver with $>10$ MHz Span . . . . .	4-26
4-12.	Typical Sweep Ramp Display . . . . .	4-27
4-13.	10 V Reference Detector . . . . .	4-28
4-14.	-10 V Reference Detector . . . . .	4-29
4-15.	YTF Driver . . . . .	4-30
4-16.	A16U12 Pin Location . . . . .	4-32
5-1.	A15 Motherboard Connector Designation . . . . .	5-12
5-2.	A15 Connectors with Additional Associated Circuitry (1 of 2) . . . . .	5-13
5-2.	A15 Connectors with Additional Associated Circuitry (2 of 2) . . . . .	5-14
5-3.	A15J13 Connector-Pin Designation . . . . .	5-15
5-4.	Card-Cage Connector Pin Designation . . . . .	5-16
6a-1.	A7J2 Pin-Out . . . . .	6a-2
7-1.	A1 Front-Frame Replacement . . . . .	7-5
7-2.	A2 Display Replacement . . . . .	7-9
7-3.	CRT Assembly . . . . .	7-10
7-4.	A2 Display, Rear View . . . . .	7-11
7-5.	RF Assembly Replacement . . . . .	7-14
7-6.	A3 Front-End Bracket Assembly . . . . .	7-17
7-7.	A3 Front-End Replacement, Bottom View . . . . .	7-18
7-8.	A3 Front-End Replacement, Top View . . . . .	7-20
7-9.	A7 Analog Interface Assembly Replacement . . . . .	7-23
7-10.	End View of Connectors for W12, W35, and W36 . . . . .	7-24
7-11.	A8 Power Supply Replacement . . . . .	7-26
7-12.	A15 Motherboard Replacement . . . . .	7-28
7-13.	A15 Motherboard with IF Section . . . . .	7-29
7-14.	A16 Processor/Video Board Replacement . . . . .	7-33
7-15.	A16 Processor/Video Board Firmware ROM Replacement . . . . .	7-37
7-16.	A17 Memory Card Reader Replacement . . . . .	7-41
7-17.	A25 Counter-Lock Replacement . . . . .	7-43
7-18.	B1 Fan Replacement . . . . .	7-44
7-19.	Rear Frame Replacement . . . . .	7-47
8-1.	Typical Serial-Number Label . . . . .	8-3
9-1.	Foldout 9-1. HP 8590 E-Series and L-Series, HP 8591C and HP 8594Q IF Control Overall Block Diagram . . . . .	9-17
9-2.	Foldout 9-2. HP 8590L, HP 8591C and HP 8591E RF Section, Overall Block Diagram . . . . .	9-19
9-3.	Foldout 9-3. HP 8592L and HP 8593E RF Section, Overall Block Diagram . . . . .	9-21
9-4.	Foldout 9-4. HP 8594E, HP 8594L, HP 8595E, HP 8596E RF Section, Overall Block Diagram . . . . .	9-23
9-5.	Foldout 9-5. LO Section, Block Diagram . . . . .	9-25
9-6.	Foldout 9-6. HP 8590 C-Series, E-Series, L-Series, and Q-Series A9 Third Converter Assembly, Block Diagram . . . . .	9-27
10-1.	Foldout 10-1. HP 8590L/91C/91E Tracking Generator Option 010 and 011, Overall Block Diagram . . . . .	10-41
10-2.	Foldout 10-2. HP 8593E, 94E, 95E, 96E A10 Tracking Generator Option 010 Overall Block Diagram . . . . .	10-43
10-3.	Foldout 10-3. HP 8590 E-Series and HP 8591 C-Series AM/FM Demod TV Trigger Block Diagram . . . . .	10-45
10-4.	Foldout 10-4. HP 8590 E-Series AM/FM Demod Quasi-Peak Detector Block Diagram . . . . .	10-47
10-5.	Foldout 10-5. HP 859Q Option 190 DVB-C QAM Analyzer Hardware Diagram . . . . .	10-49

11-1. A1 Front-Frame Assembly, Front and Rear Views HP 8590 E-Series and L-Series Spectrum Analyzers, HP 8591C Cable TV Analyzer, and HP 8594Q QAM Analyzers . . . . .	11-2
11-2. Instrument Top View HP 8590L, HP 8591C, and HP 8591E . . . . .	11-3
11-3. Instrument Top View HP 8592L, HP 8593E, HP 8594E, HP 8594L, HP 8594Q, HP 8595E, and HP 8596E . . . . .	11-4
11-4. A7A1 Left-Side View HP 8590L, HP 8591C, and HP 8591E . . . . .	11-5
11-5. Card-Cage (Options 102, 103) HP 8590 E-Series, HP 8591C Cable TV Analyzers, and HP 8594Q QAM Analyzers . . . . .	11-6
11-6. Card-Cage (Options 009, 010) HP 8593E, HP 8594E, HP 8594Q, HP 8595E, and HP 8596E . . . . .	11-7
11-7. Card-Cage (Option 103) HP 8590 E-Series . . . . .	11-8
11-8. Card-Cage (Option 107) HP 8591C and HP 8590 E-Series . . . . .	11-9
11-9. Card-Cage (Option 190) HP 8594Q . . . . .	11-10
11-10. Instrument Bottom View with A25 Counter-Lock Removed HP 8590 E-Series and L-Series Spectrum Analyzers, HP 8591C Cable TV Analyzer, and HP 8594Q QAM Analyzers . . . . .	11-11
11-11. Instrument Bottom View HP 8590 E-Series and L-Series Spectrum Analyzers, HP 8591C Cable TV Analyzers, and HP 8594Q QAM Analyzers . . . . .	11-12
11-12. Front-End Assembly, Top View HP 8590L and HP 8591E . . . . .	11-13
11-13. Front-End Assembly, Left-Side View HP 8590L and HP 8591E . . . . .	11-13
11-14. Front-End Assembly, Top View HP 8591C . . . . .	11-14
11-15. Front-End Assembly, Left-Side View HP 8591C . . . . .	11-14
11-16. YTO Assembly HP 8590L, HP 8591C, and HP 8591E . . . . .	11-15
11-17. A24 Tracking Generator HP 8590L (Options 010 and 011) . . . . .	11-16
11-18. A24 Tracking Generator HP 8591C (Option 011) and HP 8591E (Options 010 and 011) . . . . .	11-17
11-19. A3 Front-End Assembly, Top and Left-Side Views HP 8592L, HP 8593E, HP 8594E, HP 8594L, HP 8594Q, HP 8595E, and HP 8596E . . . . .	11-18
11-20. A3 Front-End Assembly, Right-Side View HP 8592L . . . . .	11-19
11-21. A3 Front-End Assembly, Right-Side View HP 8593E . . . . .	11-20
11-22. A3 Front-End Assembly, Right-Side View HP 8594E and HP 8594L . . . . .	11-21
11-23. A3 Front-End Assembly, Right-Side View HP 8595E and HP 8596E . . . . .	11-22
11-24. A3 Front-End Assembly, Rear View with A3A5 Removed HP 8592L and HP 8593E (Options 009 and 010) . . . . .	11-23
11-25. A3 Front-End Assembly, Rear View with A3A5 Removed HP 8594E (Options 009 and 010) . . . . .	11-24
11-26. A3 Front-End Assembly, Rear View with A3A5 Removed HP 8595E and HP 8596E (Options 009 and 010) . . . . .	11-25
11-27. A3 Front-End Assembly, Right-Side View HP 8593E (Options 009 and 010) . . . . .	11-26
11-28. A3 Front-End Assembly, Right-Side View HP 8594E (Options 009 and 010) . . . . .	11-27
11-29. A3 Front-End Assembly, Right-Side View HP 8595E and HP 8596E (Options 009 and 010) . . . . .	11-28
11-30. A3 Front-End Assembly, Rear View with A3A5 Removed HP 8593E (Options 009 and 010) . . . . .	11-29
11-31. A3 Front-End Assembly, Rear View with A3A5 Removed HP 8594E (Options 009 and 010) . . . . .	11-30
11-32. A3 Front-End Assembly, Rear View with A3A5 Removed HP 8595E and HP 8596E (Options 009 and 010) . . . . .	11-31
12-1. Handle Assembly Parts Identification . . . . .	12-32
12-2. Cover Assembly Parts Identification . . . . .	12-33
12-3. Rear Frame Assembly Parts Identification . . . . .	12-35
12-4. IF Assembly Parts Identification . . . . .	12-35
12-5. Chassis Side Views Parts Identification . . . . .	12-36
12-6. Chassis Top View Parts Identification . . . . .	12-37

12-7. Chassis Bottom View Parts Identification . . . . .	12-38
12-8. Impact Cover Parts Identification . . . . .	12-39
12-9. Foldout 12-1. HP 8592L, HP 8593E, HP 8595E, HP 8596E A3 Front-End Assembly . . . . .	12-45
12-10. Foldout 12-2. HP 8594E/94L A3 Front-End Assembly . . . . .	12-47
12-11. Foldout 12-3. HP 8590L and HP 8591E RF Assembly . . . . .	12-49
12-12. Foldout 12-4. HP 8590L, HP 8591C, and HP 8591E Tracking Generator Assembly	12-51
12-13. Foldout 12-5. HP 8590 E-Series and L-Series, HP 8591C, and HP 8594Q Parts Identification, Front Frame . . . . .	12-53
12-14. Foldout 12-6. HP 8591C RF Assembly . . . . .	12-55
12-15. Foldout 12-7. HP 8594Q A3 Front-end Assembly . . . . .	12-57
13-1. Calibration, Service, and Diagnostic Softkey Tree: HP 8590 E-Series and L-Series, and HP 8594Q QAM Analyzers . . . . .	13-2
13-2. Calibration, Service, and Diagnostic Softkey Tree: HP 8591C . . . . .	13-3
13-3. Default Calibration Data: Page 1 . . . . .	13-24
13-4. Default Calibration Data: Page 2 . . . . .	13-25
13-5. Default Calibration Data: Page 3 (Option 130 only) . . . . .	13-25
13-6. Typical Calibration Data: Page 1 . . . . .	13-26
13-7. Typical Calibration Data: Page 2 . . . . .	13-26
13-8. Typical Calibration Data: Page 3 (Option 130 only) . . . . .	13-27
13-9. LO Frequency Diagnostic Data Display . . . . .	13-37
14-1. A16J1 Connector-Pin Orientation . . . . .	14-3
14-2. A16J1 Connector-Pin Orientation . . . . .	14-5
15-1. Special Service Tools . . . . .	15-4

# Tables

---

1-1. HP 8590 E-Series and L-Series Spectrum Analyzer, HP 8591C Cable TV Analyzer and HP 8594Q QAM Analyzer Frequency Ranges . . . . .	1-3
1-2. HP 8590L and HP 8591E Spectrum Analyzer and HP 8591C Cable TV Analyzer & Maximum Safe Input Level . . . . .	1-7
1-3. HP 8592L and HP 8593E Spectrum Analyzer Maximum Safe Input Level . . . . .	1-7
1-4. HP 8594E and HP 8594L Spectrum Analyzer and HP 8594Q Analyzer Maximum Safe Input Level . . . . .	1-7
1-5. HP 8595E and HP 8596E Spectrum Analyzer Maximum Safe Input Level . . . . .	1-7
2-1. HP 8590 E-Series and L-Series Spectrum Analyzer, HP 8591C Cable TV and HP 8594Q QAM Analyzer Adjustment Procedures . . . . .	2-1
2-2. Adjustments and Tests for Replaced or Repaired Assemblies . . . . .	2-4
2-3. Bandwidth Amplitude-Correction Map . . . . .	2-29
2-4. A12 Amplitude Control Assembly Attenuator Errors . . . . .	2-32
2-5. Log Fidelity Check . . . . .	2-37
2-6. Linear Gain Check . . . . .	2-37
2-7. Acceptable Mixer Bias DAC Correction Values . . . . .	2-43
2-8. Frequency Response Errors . . . . .	2-69
2-9. Analyzer Bands Measured and Adjusted . . . . .	2-71
2-10. Frequency Response Errors Band 0 . . . . .	2-78
2-11. Frequency Response Errors Band 1 . . . . .	2-80
2-12. Frequency Response Errors Band 2 . . . . .	2-80
2-13. Frequency Response Errors Band 3 . . . . .	2-82
2-14. Frequency Response Errors Band 4 . . . . .	2-83
2-15. Frequency Response Errors Band 4 ( <i>Option 026</i> ) . . . . .	2-84
2-16. Tracking Oscillator Range Centering . . . . .	2-105
2-17. Log Fidelity . . . . .	2-107
2-18. Frequency Response Attenuator 10 dB . . . . .	2-108
2-19. Frequency Response Attenuator 20 dB . . . . .	2-109
2-20. Frequency Response Attenuator 30 dB . . . . .	2-109
2-21. Frequency Response Attenuator 40 dB . . . . .	2-110
2-22. Frequency Response Errors: HP 8593E, 8594E, 8595E, 8596E . . . . .	2-112
2-23. Frequency Response Errors: HP 8591C and HP 8591E . . . . .	2-112
2-24. Log Fidelity . . . . .	2-114
2-25. Frequency Response Attenuator 10 dB . . . . .	2-115
2-26. Frequency Response Attenuator 20 dB . . . . .	2-116
2-27. Frequency Response Attenuator 30 dB . . . . .	2-116
2-28. Frequency Response Attenuator 40 dB . . . . .	2-117
2-29. Frequency Response Attenuator 10 dB . . . . .	2-118
2-30. Frequency Response Attenuator 20 dB . . . . .	2-119
2-31. Frequency Response Attenuator 30 dB . . . . .	2-119
2-32. Frequency Response Attenuator 40 dB . . . . .	2-120
2-33. Frequency Response Errors: HP 8593E, 8594E, 8595E, 8596E . . . . .	2-122
2-34. Frequency Response Errors: HP 8591C and HP 8591E . . . . .	2-122
2-35. Frequency Response Errors: HP 8593E, 8594E, 8595E, 8596E . . . . .	2-123
2-36. Frequency Response Errors: HP 8591C and HP 8591E . . . . .	2-123

3-1. RTXO Timebase Correction Constant (Instruments without precision frequency reference) . . . . .	3-9
3-2. Frequency Response Correction Constants for the HP 8590L, HP 8591C, or HP 8591E . . . . .	3-9
3-3. Frequency-Response Correction Constants for HP 8592L, HP 8593E, HP 8594E, HP 8594L, HP 8594Q, HP 8595E, or HP 8596E Band 0 . . . . .	3-10
3-4. Frequency-Response Correction Constants for HP 8592L, HP 8593E, HP 8595E, or HP 8596E Band 1 . . . . .	3-10
3-5. Frequency-Response Correction Constants for HP 8592L, HP 8593E, or HP 8596E Band 2 . . . . .	3-11
3-6. Frequency-Response Correction Constants for HP 8592L or HP 8593E Band 3 . . . . .	3-11
3-7. Frequency-Response Correction Constants for HP 8592L or HP 8593E Band 4 . . . . .	3-12
3-8. Frequency-Response Correction Constants for HP 8592L or HP 8593E Band 4 (Option 026) . . . . .	3-12
3-9. A12 Step-Attenuator Correction Constants . . . . .	3-13
3-10. CALTGX Correction Constants (Options 010 and 011) . . . . .	3-13
4-1. Instrument Failure Symptoms at Power-On . . . . .	4-4
4-2. Power Supply Tolerances . . . . .	4-6
4-3. Free-Run Mode Test Points on A16 . . . . .	4-33
5-1. Nominal Resolution Bandwidth Control Line Voltages . . . . .	5-6
5-2. IF Section Gain Table in dB . . . . .	5-8
5-3. 10 dB Step-Gain Control Lines . . . . .	5-9
5-4. Calibration-Attenuator Control Lines . . . . .	5-9
5-5. Linear Gain Control Lines on the A14 Assembly . . . . .	5-10
5-6. A15 Motherboard Mnemonic Descriptions . . . . .	5-17
5-7. A15 Motherboard Pin Designations . . . . .	5-21
6a-1. Power Levels at Measurement Points . . . . .	6a-1
6a-2. A7J2 Connector Pin Designation (Top-Side View) . . . . .	6a-2
6a-3. Input Attenuator Control Output at A7J2 . . . . .	6a-3
6b-1. Power Levels at Measurement Points . . . . .	6b-2
6b-2. A7J2 Connector Pin Designation for HP 8592L, 8593E, 8596E . . . . .	6b-3
6b-3. A7J2 Connector Pin Designation for Option 026 for HP 8595E . . . . .	6b-3
6b-4. A7J4 2nd Converter Drive Pin Designation for HP 8592L, HP 8593E, HP 8594E, HP 8594L, HP 8594Q, HP 8595E, HP 8596E . . . . .	6b-4
6b-5. A7J301 YTF Driver Pin Designation for HP 8592L, 8593E, 8595E, 8596E . . . . .	6b-4
6b-6. A10J1 Tracking Generator Control Pin Designation for HP 8593E, HP 8594E, HP 8594L, HP 8594Q, HP 8595E, HP 8596E . . . . .	6b-4
6b-7. Input Attenuator Control Output at A7J5 for HP 8592L and 8593E . . . . .	6b-5
6b-8. Input Attenuator Control Output at A7J5 for HP 8594E, HP 8594L, HP 8594Q, HP 8595E, HP 8596E . . . . .	6b-6
8-1. Hewlett-Packard Sales and Service Offices . . . . .	8-5
9-1. HP 8590 E-Series and L-Series Spectrum Analyzer, HP 8591C Cable TV Analyzer, and HP 8594Q QAM Analyzer Frequency Ranges . . . . .	9-1
10-1. Option Table . . . . .	10-2
10-2. Tracking Generator Control Signals at A7A1J7 . . . . .	10-12
10-3. Tracking Generator Bias Voltages from A7A1 to A24A2 . . . . .	10-13
12-1. Reference Designations, Abbreviations and Multipliers (1 of 4) . . . . .	12-4
12-1. Reference Designations, Abbreviations, and Multipliers (2 of 4) . . . . .	12-5
12-1. Reference Designations, Abbreviations, and Multipliers (3 of 4) . . . . .	12-6
12-1. Reference Designations, Abbreviations, and Multipliers (4 of 4) . . . . .	12-7
12-2. Standard Value Replacement Capacitors . . . . .	12-8
12-3. Standard Value Replacement Resistors, 0.125 W . . . . .	12-9
12-4. Standard Value Replacement Resistors, 0.5 W . . . . .	12-11
12-5. Assembly-Level Replaceable Parts . . . . .	12-13
12-6. Replaceable Cables . . . . .	12-20

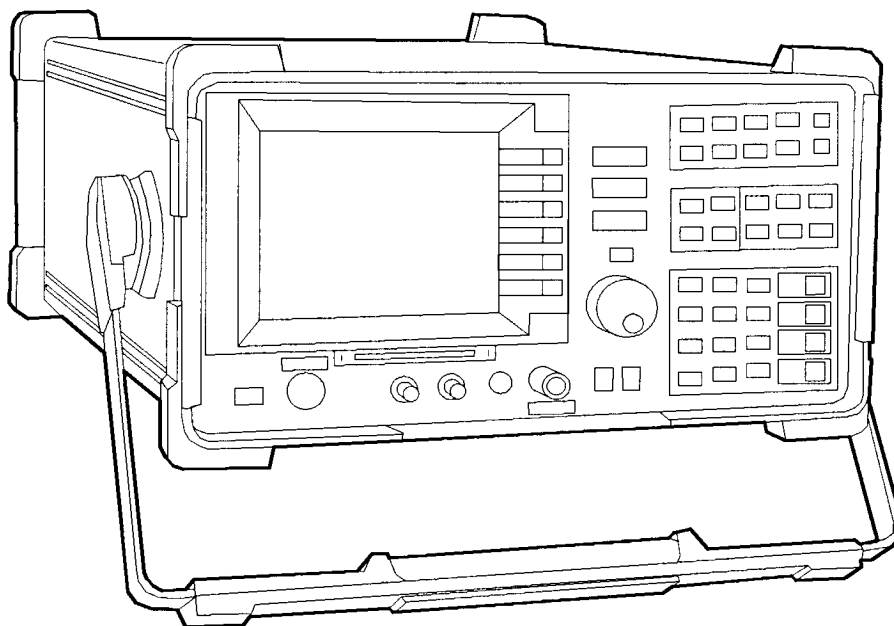


12-7. HP 8590 E-Series and L-Series Spectrum Analyzer Board Assembly, Serial Number, and CLIP Part Number Cross-Reference . . . . .	12-28
14-1. Possible Cause of the Error Message ADC-GND FAIL . . . . .	14-2
14-2. Possible Cause of the Error Message ADC-2V FAIL . . . . .	14-4
14-3. Four-Digit Failure Code Interpretation . . . . .	14-17
14-4. I/O Bus Address Failure-Code Interpretation . . . . .	14-18
14-5. I/O Data Bus Failure Code Interpretation . . . . .	14-18
14-6. A16 Video Ram Address Failure Code Interpretation . . . . .	14-19
15-1. Static-Safe Accessories . . . . .	15-2
15-2. Special Service Tools . . . . .	15-3
15-3. Required Common Hand Tools . . . . .	15-5

## Introduction

---

The *HP 8590 Series Analyzers Assembly-Level Repair Service Guide* provides the information needed to adjust and repair the HP 8590 E-Series and L-Series spectrum analyzers, the HP 8591C cable TV analyzer and HP 8594Q QAM analyzer to the assembly level.



sh244e

**HP 8590 E-Series and L-Series Spectrum Analyzers,  
HP 8591C Cable TV Analyzers, and HP 8594Q QAM Analyzer**

The *HP 8590 Series Analyzers Component-Level Repair Service Guide* provides component-level information for the repair of individual analyzer assemblies. The binder contains Component-Level Information Packets (CLIPs) for selected assemblies. Each CLIP contains component-level schematics, a component parts list, and illustrations for component location by reference designator. Each CLIP has its own HP part number which is changed whenever the HP part number for its related analyzer assembly is changed. A list of all CLIP part numbers for the HP 8590 E-Series and L-Series spectrum analyzers, HP 8591C cable TV analyzers, and HP 8594Q QAM analyzers is provided in Chapter 12 of this service guide.

---

## Service Guide Organization

The guide is divided into the following chapters.

- **Chapter 1**, “Introduction,” contains information on the analyzer identification, firmware revisions and upgrades, and safety and reliability considerations.
- **Chapter 2**, “Making Adjustments,” contains the adjustment procedures needed to adjust the analyzer to meet its specifications.
- **Chapter 3**, “Backing Up and Reloading Correction Constants,” contains information for safe-guarding the correction data stored in the analyzer and restoring the analyzer memory.
- **Chapter 4**, “Troubleshooting the Analyzer,” contains information for starting to troubleshoot a analyzer failure.
- **Chapter 5**, “Troubleshooting the IF Section,” contains specific troubleshooting information for selected assemblies in the IF section and the A15 Motherboard assembly.
- **Chapter 6**, “Troubleshooting the RF Section,” contains troubleshooting information for the RF and LO sections of the HP 8590 E-Series and L-Series spectrum analyzer and HP 8591C cable TV analyzer. The information is separated by the following tabs.
  - 6a**, “HP 8590L, HP 8591C and HP 8591E,” contains specific troubleshooting information for selected assemblies within the RF and LO sections of the HP 8590L, HP 8591E spectrum analyzers, and HP 8591C cable TV analyzers.
  - 6b**, “HP 8592L/94L, HP 8594Q, and HP 8593E/94E/95E/96E,” contains specific troubleshooting information for selected assemblies within the RF and LO sections of the HP 8592L, HP 8594L, HP 8593E, HP 8594E, HP 8595E, HP 8596E spectrum analyzers, and the HP 8594Q QAM analyzer.
- **Chapter 7**, “Replacing Major Assemblies,” contains instructions for the removal and replacement of most major assemblies.
- **Chapter 8**, “Contacting Hewlett-Packard,” contains information on how to contact Hewlett-Packard and return the analyzer for repair.
- **Chapter 9**, “Assembly Descriptions and Block Diagrams,” contains information and block diagrams describing analyzer operation and individual assemblies.
- **Chapter 10**, “Analyzer Options and Block Diagrams,” contains information on the available analyzer options.
- **Chapter 11**, “Major Assembly and Cable Locations,” contains figures identifying all major assemblies and cables.
- **Chapter 12**, “Replaceable Parts,” contains information needed to order assemblies and component-level information for the analyzer.
- **Chapter 13**, “Softkey Descriptions,” contains a description of the calibration, service, and diagnostic softkeys.
- **Chapter 14**, “Analyzer Messages,” contains a description of the analyzer messages that are displayed when there is a problem with the analyzer.
- **Chapter 15**, “Service Equipment and Tools,” contains information about equipment and tools used to service the analyzer.

---

## Analyzer Description

The HP 8590 E-Series and L-Series spectrum analyzers, HP 8591C cable TV analyzers, and HP 8594Q QAM analyzers provide measurement capabilities over the RF and Microwave frequency ranges.

The frequency ranges of HP 8590 E-Series and L-Series spectrum analyzers, HP 8591C cable TV analyzers, and HP 8594Q QAM analyzers are described below.

**Table 1-1.**  
**HP 8590 E-Series and L-Series Spectrum Analyzer,**  
**HP 8591C Cable TV Analyzer and HP 8594Q QAM Analyzer Frequency**  
**Ranges**

Analyzer Model	Frequency Range
HP 8590L	9 kHz to 1.8 GHz
HP 8591E	9 kHz to 1.8 GHz
HP 8591C	1 MHz to 1.8 GHz
HP 8592L	9 kHz to 22.0 GHz
HP 8592L ( <i>Option 026</i> )	9 kHz to 26.5 GHz
HP 8593E	9 kHz to 22.0 GHz
HP 8593E ( <i>Option 026</i> )	9 kHz to 26.5 GHz
HP 8594E	9 kHz to 2.9 GHz
HP 8594L	9 kHz to 2.9 GHz
HP 8594Q	9 kHz to 2.9 GHz
HP 8595E	9 kHz to 6.5 GHz
HP 8596E	9 kHz to 12.8 GHz

All HP 8590 E-Series spectrum analyzers, HP 8591C cable TV analyzers and HP 8594Q QAM analyzers are equipped with a memory card reader. The memory card reader allows the analyzer to use downloadable software programs. The functional “personality” of the analyzer can also be altered using the memory card reader. This feature provides the user with one analyzer that can perform the function of other types of microwave test equipment.

Further information about the HP 8590 E-Series and L-Series spectrum analyzers, and the available options, is provided in Chapter 10 of this service guide and the *HP 8590 E-Series and L-Series Spectrum Analyzers User's Guide*. Further information about the HP 8591C cable TV analyzer and HP 8594Q QAM analyzer is provided in the spectrum analyzer reference for your instrument. Further information about the HP 8594Q QAM analyzer is provided in *HP 8594Q QAM Analyzer Spectrum Analyzer Reference User's Guide*.

---

## Firmware Revision Date

When the analyzer is first turned on, a display appears that contains the copyright date and firmware revision date. (If the analyzer has either Option 041, HP-IB and parallel I/O, or Option 043, RS-232 and parallel I/O, the display will also contain the entries shown on the first line of the example below.)

The version of firmware installed in the analyzer is identified by the year, month, and day in the following format.

```
(HP-IB: nn) or (RS232: nnnn)
COPYRIGHT HP 1986
rev yy.mm.dd
```

Whenever you contact Hewlett-Packard about your analyzer, be sure to provide the firmware date along with the complete serial number and option designation. This will ensure that you obtain accurate service information.

---

## Firmware Upgrade Kit Ordering Information

There are occasions when the factory revises the analyzer firmware to correct defects or make performance improvements. When a firmware revision is needed, a service note is distributed by the factory to all Hewlett-Packard service centers. The service note identifies, by serial-number prefix, the analyzers that require the latest firmware upgrade kit.

If your analyzer requires a firmware upgrade kit, it can be obtained by ordering as described in Chapter 12.

Instructions for the replacement of the firmware ROMs is located under "A16 Processor/Video Board Firmware ROM" in Chapter 7 of this guide.

---

## Safety Considerations

Before servicing the analyzer, familiarize yourself with the safety markings on the analyzer and the safety instructions in this manual. This analyzer has been manufactured and tested according to international safety standards. To ensure safe operation of the instrument and the personal safety of the user and service personnel, the cautions and warnings in this manual must be heeded.

Refer to the summary of safety considerations at the front of this guide. Individual chapters also contain detailed safety notation.

---

**Warning**      **Failure to ground the analyzer properly can result in personal injury, as well as analyzer damage.**

**Before turning on the analyzer, connect a three-wire power cable with a standard IEC 320-C13 (CEE 22-V) inlet plug to the analyzer power receptacle. The power cable outlet plug must be inserted into a power-line outlet socket that has a protective earth-contact. DO NOT defeat the earth-grounding protection by using an extension cable, power cable, or autotransformer without a protective ground conductor.**

**If you are using an autotransformer, make sure its common terminal is connected to the protective ground conductor of its power-source outlet socket.**

---

**Warning**      **For continued protection against fire hazard replace line fuse only with same type and rating (F 5A/250V). The use of other fuses or material is prohibited.**

---

---

## **Reliability Considerations**

### **Analyzer Input Protection**

The analyzer input circuitry can be damaged by power levels that exceed the maximum safe input-level specifications. Table 1-2 through Table 1-5 provides the input specifications. To prevent input damage, these specified levels for your analyzer must not be exceeded.

The analyzer input can also be damaged by large transients. If it is likely that your analyzer will be exposed to potentially damaging transients, take whatever precautions are necessary to protect its input circuitry.

The analyzer input can easily be protected by disconnecting it from the signal source whenever it is likely that large transients will be present. When it is impractical to disconnect the analyzer, a transient-limiting device should be used.

The HP 11947A Transient Limiter is an analyzer accessory that protects the input circuitry from transients and accidental overloads. Contact your local Hewlett-Packard sales or service office for more information about the HP 11947A.

**Caution** Transients are often produced during electromagnetic interference (EMI) conducted emissions testing. One type of device, the line impedance stabilization network (LISN), can produce large transients when its switch position or voltage input is changed.

**Table 1-2.  
HP 8590L and HP 8591E Spectrum Analyzer and  
HP 8591C Cable TV Analyzer & Maximum Safe Input Level**

	INPUT 50Ω (Input Attenuation ≥10 dB)	INPUT 75Ω (Input Attenuation ≥10 dB)
Average Continuous Power	+ 30 dBm (1 W)	+ 75 dBmV (0.4 W)
Peak Pulse Power	+ 30 dBm (1 W)	+ 75 dBmV (0.4 W)
dc	25 Vdc	100 Vdc

**Table 1-3.  
HP 8592L and HP 8593E Spectrum Analyzer Maximum Safe Input Level**

	INPUT 50Ω (Input Attenuation ≥10 dB bands 1 through 4)
Average Continuous Power	+ 30 dBm (1 W, 7.1 V rms), input attenuation ≥10 dB
Peak Pulse Power	+ 50 dBm (100 W) for <10 μs pulse width and <1% duty cycle, input attenuation ≥30 dB
dc	0 Vdc

**Table 1-4.  
HP 8594E and HP 8594L Spectrum Analyzer and HP 8594Q Analyzer  
Maximum Safe Input Level**

	INPUT 50Ω (Input Attenuation ≥10 dB)
Average Continuous Power	+ 30 dBm (1 W, 7.1 V rms)
Peak Pulse Power	+ 50 dBm (100 W) for <10 μs pulse width and <1% duty cycle, input attenuation ≥30 dB
dc	0 V (dc coupled) 50 V (ac coupled)

**Table 1-5.  
HP 8595E and HP 8596E Spectrum Analyzer Maximum Safe Input Level**

	INPUT 50Ω (Input Attenuation ≥10 dB above 2.75 GHz)
Average Continuous Power	+ 30 dBm (1 W, 7.1 V rms)
Peak Pulse Power	+ 50 dBm (100 W) for <10 μs pulse width and <1% duty cycle, input attenuation ≥30 dB
dc	0 V (dc coupled) 50 V (ac coupled)



## Protection from Electrostatic Discharge

Electrostatic discharge (ESD) can damage or destroy electronic components. All work on electronic assemblies should be performed at a static-safe workstation. Figure 1-1 shows an example of a static-safe workstation using two types of ESD protection.

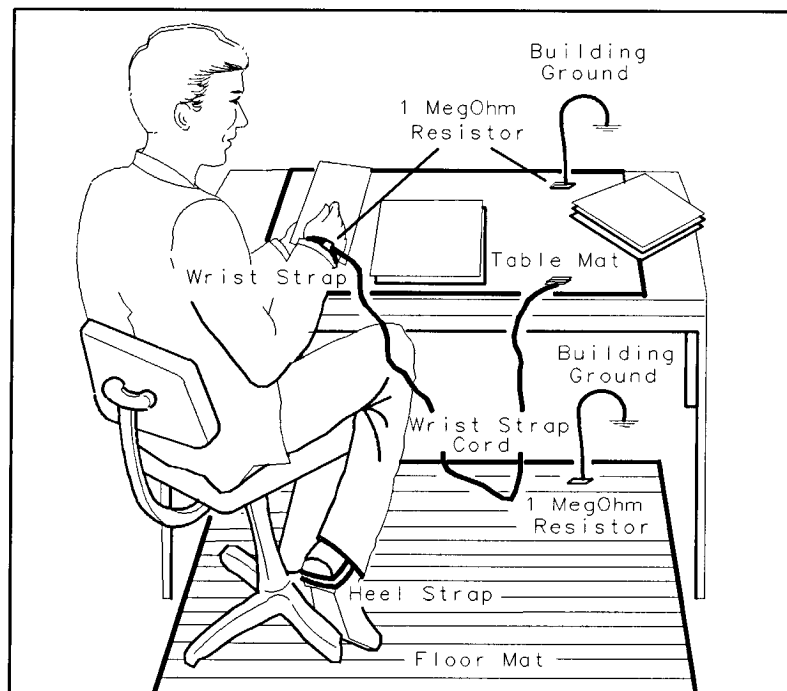
- Conductive table-mat and wrist-strap combination.
- Conductive floor-mat and heel-strap combination.

Both types, when used together, provide a significant level of ESD protection. Of the two, only the table-mat and wrist-strap combination provides adequate ESD protection when used alone. To ensure user safety, the static-safe accessories must provide at least  $1\text{ M}\Omega$  of isolation from ground. Refer to Chapter 15 for information on ordering static-safe accessories.

---

**Warning**     **These techniques for a static-safe workstation should not be used when working on circuitry with a voltage potential greater than 500 volts.**

---



FORMAT46

**Figure 1-1. Example of a Static-Safe Workstation**

## **Handling of Electronic Components and ESD**

The possibility of unseen damage caused by ESD, is present whenever components are transported, stored, or used. The risk of ESD damage can be greatly reduced by close attention to how all components are handled.

- Perform work on all components at a static-safe workstation.
- Keep static-generating materials at least one meter away from all components.
- Store or transport components in static-shielding containers.

---

**Caution** Always handle printed circuit board assemblies by the edges. This will reduce the possibility of ESD damage to components and prevent contamination of exposed plating.

---

## **Test Equipment Usage and ESD**

- Before connecting any coaxial cable to an analyzer connector for the first time each day, momentarily short the center and outer conductors of the cable together.
- Personnel should be grounded with a 1 M  $\Omega$  resistor-isolated wrist-strap before touching the center pin of any connector and before removing any assembly from the analyzer.
- Be sure that all analyzers are properly earth-grounded to prevent build-up of static charge.

## **For Additional Information about ESD**

For more information about preventing ESD damage, contact the Electrical Overstress/Electrostatic Discharge (EOS/ESD) Association, Inc. The ESD standards developed by this agency are sanctioned by the American National Standards Institute (ANSI).

## Making Adjustments

The procedures in this chapter adjust the analyzer electrical performance to the specifications described in Chapter 2 of the calibration guide for your instrument.

Most adjustments require access to the interior of the analyzer.

Commands within parenthesis after a softkey, for example (ON), are used throughout this chapter to indicate the part of a softkey that should be underlined when the key is pressed.

The following table lists the procedures included in this chapter and the analyzer models that they apply to.

**Table 2-1.**  
**HP 8590 E-Series and L-Series Spectrum Analyzer,**  
**HP 8591C Cable TV and HP 8594Q QAM Analyzer Adjustment Procedures**

Adjustment Procedure Name		Adjustment for Spectrum Analyzer HP Model:								
		8590L	8591C	8591E	8592L	8593E 8596E	8594E	8594L	8594Q	8595E
1.	Display	•	•	•	•	•	•	•	•	•
2.	Sampler Match	•	•	•	•	•	•	•	•	•
3.	10 MHz Reference	•	•	•	•	•	•	•	•	•
4.	10 MHz Precision Frequency Reference		•	•		•	•		•	•
5.	Crystal and LC Bandwidth Filter	•	•	•	•	•	•	•	•	•
6.	Cal Attenuator Error	•	•	•	•	•	•	•	•	•
7.	Log and Linear Amplifier	•	•	•	•	•	•	•	•	•
8.	CAL FREQ Adjustment Routine	•	•	•	•	•	•	•	•	•
9.	CAL AMPTD Adjustment Routine	•	•	•	•	•	•	•	•	•
10.	CAL YTF Adjustment Routine				•	•				•
11.	CAL MXR Adjustment Routine				•	•				•
12.	Second Converter	•	•	•						
13.	Third Converter and Second IF Bandpass	•	•	•	•	•	•	•	•	•
14.	Comb Generator				•	•				
15.	Frequency Response of the HP 8590L, HP 8591C, and HP 8591E	•	•	•						
16.	Frequency Response of the HP 8592L, 8593E, 8594E, 8594L, 8594Q, 8595E, 8596E				•	•	•	•	•	•
17.	Time and Date	•	•	•	•	•	•	•	•	•

**Table 2-1.  
 HP 8590 E-Series and L-Series Spectrum Analyzer,  
 HP 8591C Cable TV and HP 8594Q QAM Analyzer Adjustment Procedures  
 (continued)**

Adjustment Procedure Name		Adjustment for Spectrum Analyzer HP Model:								
		8590L	8591C	8591E	8592L	8593E 8596E	8594E	8594L	8594Q	8595E
18.	Modulator Offset and Gain for Option 010 or 011	•	•	•						
19.	Entering External ALC Correction Constants for Option 010 or 011	•	•	•						
20.	Checking the External ALC for Option 010 or 011	•	•	•						
21.	Correcting the External ALC Error for Option 010 or 011	•	•	•						
22.	First LO Distribution Amplifier for Option 009 or 010					•	•			•
23.	BITG Power Level for Option 010					•	•			•
24.	Tracking Oscillator for Option 010					•	•		•	
25.	Checking the Absolute Amplitude Accuracy for Option 050			•		•	•			•
26.	Correcting for Absolute Amplitude Accuracy for Option 050			•		•	•			•
27.	Checking the Absolute Amplitude Accuracy for Option 051			•		•	•			•
28.	Correcting for Absolute Amplitude Accuracy for Option 051			•		•	•			•

---

## Safety

Familiarize yourself with the safety symbols marked on the analyzer, and read the general safety considerations and the safety note definitions given in the front of this guide *before* you begin the procedures in this chapter.

---

## Before You Start

There are three things you should do before starting an adjustment procedure.

- Check that you are familiar with the safety symbols marked on the analyzer, and read the general safety considerations and the symbol definitions given in the front of this service guide.
- Check that the analyzer has been turned on and allowed to warm up for at least 30 minutes at room temperature before making any adjustments. The analyzer *must* be allowed to stand at room temperature at least 2 hours prior to the 30 minute warmup.
- Read the rest of this section.

## Test equipment you will need

Refer to Chapter 1 of the calibration guide for your instrument for a list of recommended equipment for the analyzer adjustments. Any equipment that meets the critical specifications given in the table can be substituted for the recommended model.

## If there are abnormal indications during adjustment

If the indications received during an adjustment do not agree with the normal conditions given in the adjustment procedures, a fault exists in your analyzer. The fault should be repaired *before* proceeding with any further adjustments. Refer to the troubleshooting and repair information in Chapter 4 of this guide.

## Periodically verifying calibration

The analyzer requires periodic verification of operation. Under most conditions of use, you should test the analyzer at least once a year with either operation verification or the complete set of performance verification tests located in the calibration guide for your instrument.

When test results show proper operation and calibration, no adjustments are necessary. However, if test results indicate that the instrument does not meet specifications, the cause should be determined and rectified. Refer to the troubleshooting information in Chapter 4 before attempting recalibration.

## Standard-value replacement components

Part numbers for standard-value replacement components used in the adjustment procedures are located in Chapter 12 of this service guide.

## If you replace or repair an assembly

If one or more analyzer assemblies has been replaced or repaired, related adjustment procedures should be done prior to verifying operation. Refer to Table 2-2 to determine which adjustment to perform after replacing or repairing an assembly. Find the assembly that has been repaired or replaced in the left-hand column. Then perform the adjustments marked across the adjustment column for that assembly. It is important that adjustments are performed in the order indicated to ensure that the instrument meets all of its specifications.

**Table 2-2. Adjustments and Tests for Replaced or Repaired Assemblies**

Replaced or Repaired Assembly	Related Adjustments and Adjustment Routines	Related Performance Verification Tests
<b>A1 Front Frame</b>	CAL AMPTD	Frequency Response Residual Responses
<b>A2 Display</b>	Display CAL AMPTD	Frequency Response Residual Responses
<b>A3A1 Comb Generator</b>	Comb Generator CAL YTF	Comb Generator Frequency Accuracy Frequency Response Residual Responses
<b>A3A2 Microwave Switch</b>	CAL FREQ CAL AMPTD CAL YTF	Frequency Response Residual Responses
<b>A3A3 Low-Pass Filter</b>	CAL FREQ CAL AMPTD CAL YTF	Frequency Response Residual Responses
<b>A3A4 Second Converter</b>	CAL FREQ CAL AMPTD CAL YTF	Noise Sidebands System Related Sidebands Frequency Response Other Input Related Spurious Responses Spurious Response Gain Compression Displayed Average Noise Residual Responses
<b>A3A5 Input Attenuator</b>	CAL FREQ CAL AMPTD CAL YTF Frequency Response	Frequency Response Residual Responses
<b>A3A6 Dual Mixer or Low Band Mixer</b>	CAL FREQ CAL AMPTD CAL YTF CAL MXR Frequency Response	Noise Sidebands System Related Sidebands Frequency Response Other Input Related Spurious Responses Spurious Response Gain Compression Displayed Average Noise Residual Responses
<b>A3A7 YIG-Tuned Oscillator</b>	First LO Distribution Amplifier for Option 009 or 010  CAL FREQ CAL AMPTD CAL YTF	Frequency Readout & Marker Count Accy Noise Sidebands System Related Sidebands Residual FM Frequency Span Readout Accuracy Frequency Response Other Input Related Spurious Responses Spurious Response Residual Responses

**Table 2-2.  
Adjustments and Tests for Replaced or Repaired Assemblies (continued)**

Replaced or Repaired Assembly	Related Adjustments and Adjustment Routines	Related Performance Verification Tests
<b>A3A8 YIG-Tuned Filter or A3A8 Switched YIG-Tuned Filter</b>	CAL FREQ CAL AMPTD CAL YTF CAL MXR Frequency Response	Noise Sidebands System Related Sidebands Frequency Response Other Input Related Spurious Responses Spurious Response Displayed Average Noise Residual Responses
<b>A3A9 Bandpass Filter</b>	CAL FREQ CAL AMPTD	None
<b>A3A10 Directional Coupler</b>	CAL FREQ CAL AMPTD CAL YTF	System Related Sidebands Frequency Response Other Input Related Spurious Responses Spurious Responses Residual Responses
<b>A3A11 Step-Recovery Diode</b>	CAL FREQ CAL AMPTD	Comb Generator Frequency Accuracy
<b>A3A12 3 dB Attenuator</b>	CAL FREQ CAL AMPTD	None
<b>A3A13 Isolator</b>	CAL FREQ CAL AMPTD CAL YTF	System Related Sidebands Frequency Response Other Input Related Spurious Responses Spurious Responses Residual Responses
<b>A3A14 LO Distribution Amplifier (LODA)</b>	First LO Distribution Amplifier for Option 009 or 010 only  CAL FREQ CAL AMPTD CAL YTF	Frequency Readout and Marker Count Accuracy Noise Sidebands System Related Sidebands Residual FM Frequency Span Readout Accuracy Frequency Response Other Input Related Spurious Responses Spurious Response Residual Responses

**Table 2-2.  
Adjustments and Tests for Replaced or Repaired Assemblies (continued)**

Replaced or Repaired Assembly	Related Adjustments and Adjustment Routines	Related Performance Verification Tests
<b>A3A15 Tracking Generator</b>	First LO Distribution Amplifier for Option 009 or 010  CAL FREQ CAL AMPTD CAL YTF BITG Power Level for Option 010	Frequency Readout and Marker Count Accuracy Noise Sidebands System Related Sidebands Residual FM Frequency Span Readout Accuracy Frequency Response Other Input Related Spurious Responses Spurious Response Residual Responses
<b>A3 Input Attenuator</b>	CAL FREQ CAL AMPTD	Frequency Response
<b>A4 First Converter</b>	Frequency Response CAL FREQ CAL AMPTD	Noise Sidebands System Related Sidebands Frequency Response Spurious Response Gain Compression Displayed Average Noise Residual Responses
<b>A5 Second Converter</b>	Second Converter CAL FREQ CAL AMPTD	Noise Sidebands Residual FM System Related Sidebands Frequency Response Spurious Response Gain Compression Displayed Average Noise Residual Responses
<b>A6 YIG-Tuned Oscillator</b>	CAL FREQ CAL AMPTD	Noise Sidebands Residual FM System Related Sidebands Frequency Span Readout Accuracy Frequency Response Spurious Response Displayed Average Noise Residual Responses
<b>A7 Analog Interface</b>	CAL FREQ CAL AMPTD CAL YTF (HP 8592L, 8593E, 8595E, 8596E only)	Frequency Readout and Marker Count Accy Noise Sidebands Residual FM System Related Sidebands Frequency Span Readout Accuracy Sweptime Accuracy Scale Fidelity Reference Level Accuracy Absolute Amplitude Calibration and Resolution Bandwidth Switching Uncertainties Frequency Response
<b>A7A1 Tracking Generator Control</b>	Modulator Offset and Gain for Option 010 or 011 Entering External ALC Correction Constants for Option 010 or 011 Checking the External ALC for Option 010 or 011 Correcting the External ALC Error for Option 010 or 011	Absolute Amplitude, Vernier, and Power Sweep Accuracy Tracking Generator Level Flatness Harmonic Spurious Outputs Non-Harmonic Spurious Outputs Tracking Generator Feedthrough



**Table 2-2.  
Adjustments and Tests for Replaced or Repaired Assemblies (continued)**

<b>Replaced or Repaired Assembly</b>	<b>Related Adjustments and Adjustment Routines</b>	<b>Related Performance Verification Tests</b>
<b>A8 Power Supply</b>	None	System Related Sidebands Spurious Responses Residual Responses
<b>A9 Third Converter</b>	Third Converter & Second IF Bandpass CAL FREQ CAL AMPTD BITG Power Level for Option 010 only	Noise Sidebands System Related Sidebands Absolute Amplitude Calibration and Resolution Bandwidth Switching Uncertainties Other Input Related Spurious Spurious Responses Displayed Average Noise Residual Responses
<b>A10 LODA Control (Opt. 009) or Tracking Generator Control (Opt. 010)</b>	First LO Distribution Amplifier for Option 009 or 010 only CAL FREQ CAL AMPTD CAL YTF	Frequency Response Absolute Amplitude, Vernier and Power Sweep Accuracy Tracking Generator Level Flatness
<b>A11 Bandwidth</b>	Crystal and IC Bandwidth Filter CAL FREQ CAL AMPTD	Resolution Bandwidth Accuracy Absolute Amplitude Calibration and Bandwidth Switching Uncertainties
<b>A12 Amplitude Control</b>	CAL FREQ CAL AMPTD	Scale Fidelity Displayed Average Noise
<b>A13 Bandwidth</b>	Crystal and IC Bandwidth Filter CAL FREQ CAL AMPTD	Resolution Bandwidth Accuracy Absolute Amplitude Calibration and Bandwidth Switching Uncertainties
<b>A14 Log Amplifier</b>	Log and Linear Amplifier CAL FREQ CAL AMPTD	Scale Fidelity Reference Level Accuracy
<b>A15 Motherboard</b>	CAL FREQ CAL AMPTD	Complete Operation Verification
<b>A16 Processor/Video A16A1 Memory</b>	10 MHz Reference CAL FREQ CAL AMPTD CAL YTF (HP 8592L, 8593E, 8595E, 8596E only) CAL MXR † (HP 8592L, 8593E, 8595E, 8596E only) Cal Attenuator Error † Frequency Response † Time and Date	Reference Level Accuracy Frequency Response
† These adjustments are not necessary if valid correction constants are recovered from the defective A16 processor/video assembly. See the A16 processor/video board assembly replacement procedure in this service guide.		

---

## 1a. Display (with four access holes in top of shield)

### This adjustment applies to:

All HP 8590 E-Series and L-Series spectrum analyzers  
HP 8591C cable TV analyzers  
HP 8594Q QAM analyzers

There are two different types of displays. If your display has four holes in the top of the shield, continue with this procedure. If it has eight holes, go to the next procedure.

The horizontal and vertical display positions are adjusted using front-panel softkeys. These positions are then stored in nonvolatile memory.

There are two focus adjustments, fine and coarse. The fine adjustment is located on the left side of the display assembly and can be accessed with the instrument cover on or off. The coarse adjustment is located on the rear of the display assembly and can only be adjusted with the instrument cover off.

### Procedure

#### Display Position

1. Press the following analyzer keys to adjust the horizontal position.

**PRESET**

**CAL** More 1 of 4

**CRT HORZ POSITION**

2. Rotate the knob until the display is centered horizontally.
3. Press the following analyzer softkey to adjust the vertical position.

**CRT VERT POSITION**

4. Rotate the knob until the display is centered vertically.
5. Press the following analyzer keys to store the horizontal and vertical position values into nonvolatile memory.

**CAL**

**CAL STORE**

## 1a. Display (with four access holes in top of shield)

### Fine Focus

1. Adjust the front panel INTENSITY control for a comfortable viewing intensity.
2. Use an adjustment tool to access the fine focus adjustment. See Figure 2-1. Adjust as necessary for a focused display. If one of the end-stops of the fine focus adjustment is reached, proceed with the "Coarse Focus Adjustment" section.

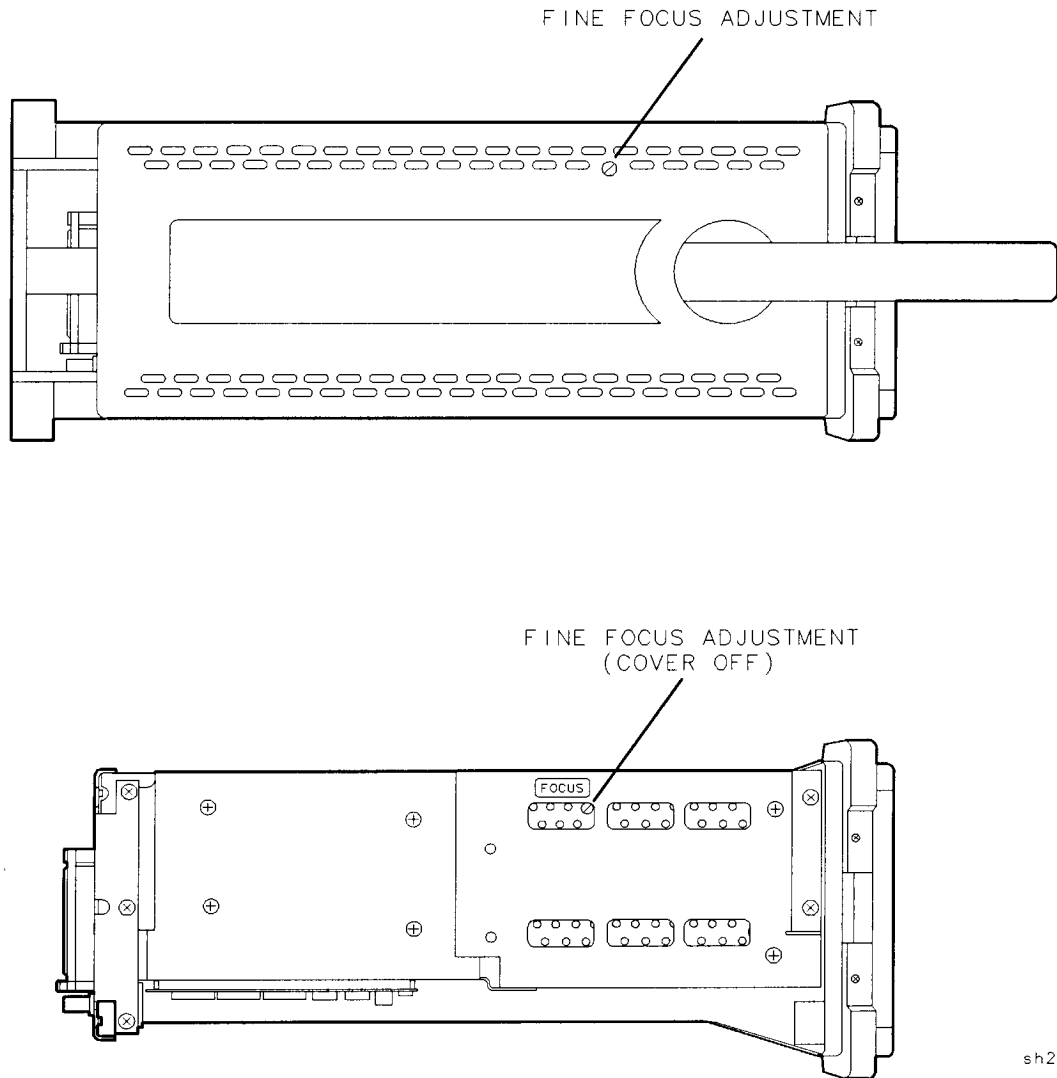


Figure 2-1. Fine Focus Adjustment Location

### 1a. Display (with four access holes in top of shield)

#### Coarse Focus

The Coarse Focus adjustment point is located at the rear of the display assembly, therefore, it is required to place the display in a service position to perform this procedure.

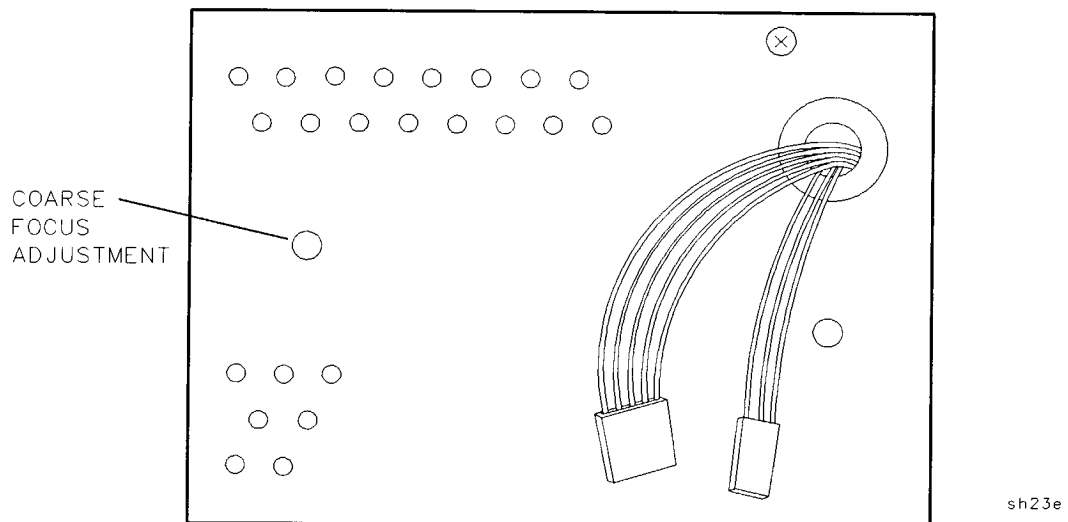
1. Turn the analyzer **(LINE)** switch to OFF. Remove the instrument cover assembly.
2. Place the display in a service position.

---

**Warning**     **The analyzer contains potentially hazardous voltages. Refer to the safety symbols provided on the analyzer, and in the general safety instructions in this guide, before operating the unit with the cover removed. Ensure that safety instructions are strictly followed. Failure to do so can result in severe or fatal injury.**

---

3. Turn the analyzer **(LINE)** switch to ON.
4. Center the fine focus adjustment. Refer to Figure 2-1 for the adjustment location.
5. Adjust the coarse focus adjustment for the best possible focus. See Figure 2-2.



**Figure 2-2. Coarse Focus Adjustment Location (rear view of display assembly)**

## 1b. Display (with eight access holes in top of shield)

---

### 1b. Display (with eight access holes in top of shield)

This adjustment applies to:

All HP 8590 E-Series and L-Series spectrum analyzers  
HP 8591C cable TV analyzers  
HP 8594Q QAM analyzers

---

**Caution** All display adjustments are described in this adjustment procedure. However, the **FOCUS** adjustment is the only adjustment that can be performed without removing the instrument cover.

For all other adjustments, it is *strongly* recommended that you return the instrument to your local sales and service office.

---

There are two different types of displays. If your display has eight holes in the top of the shield, continue with this procedure. If it has four holes, go to the preceding procedure.

If you are going to make adjustments to your display, only make the adjustments that would correct the problem that the display is experiencing.

The following is a list of adjustments described in this procedure.

- Focus
- Horizontal Hold
- Vertical Size
- Brightness
- Centering
- Vertical Hold
- Vertical Linearity
- Contrast

The horizontal and vertical display positions should first be adjusted using front-panel softkeys. These positions are then stored in nonvolatile memory.

The Focus adjustment is located on the left side of the instrument and can be accessed with the instrument cover on or off. All other adjustments must be made with the instrument cover removed.

### Equipment Required

Display adjustment tool, 0.075 inch hex (HP part number 8710-1010)

### Procedures

#### Before Performing any Adjustment

Before performing any display adjustment, press the following analyzer keys.

**CONFIG** More 1 of 3 More 2 of 3

DEFAULT SYNC

**CAL** More 1 of 4 More 2 of 4

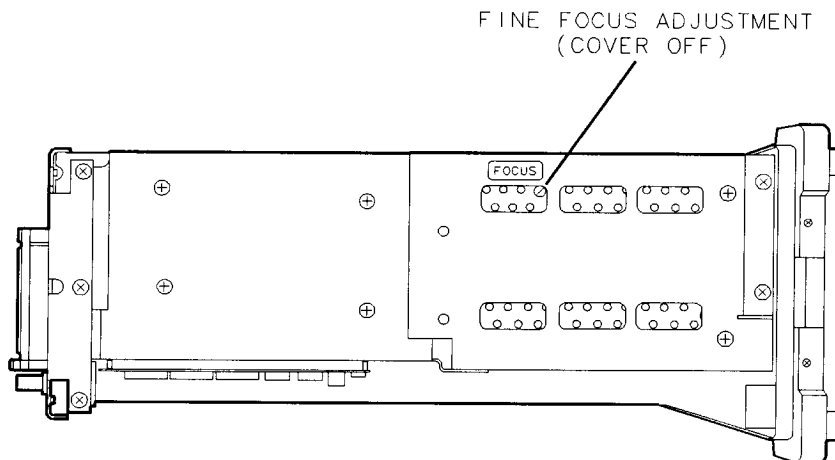
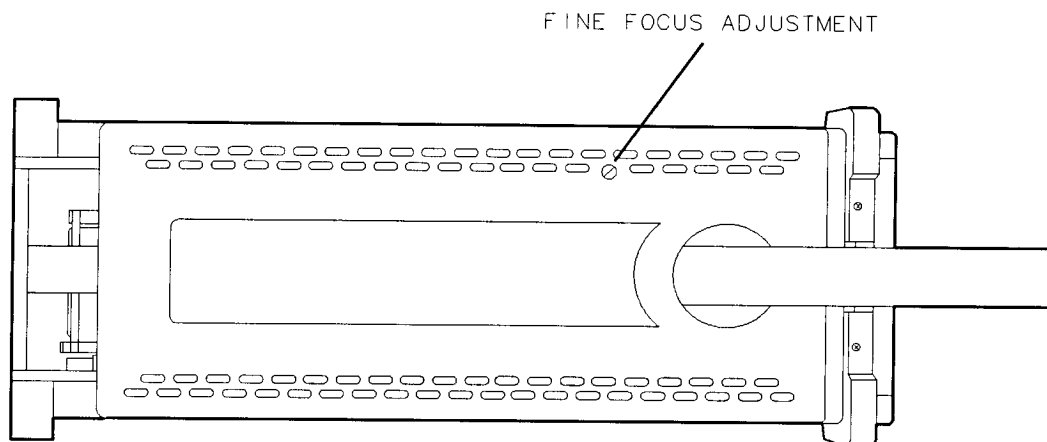
DEFAULT CAL DATA

## 1b. Display (with eight access holes in top of shield)

### Focus

The Focus potentiometer is located on the left side of the instrument and can be accessed with the instrument cover on or off. Use the specified adjustment tool to make this adjustment.

1. Adjust the front-panel INTENSITY control for a comfortable viewing intensity.
2. Adjust as necessary for a focused display. See Figure 2-1.



sh22e

**Figure 2-3. Focus Adjustment Location**

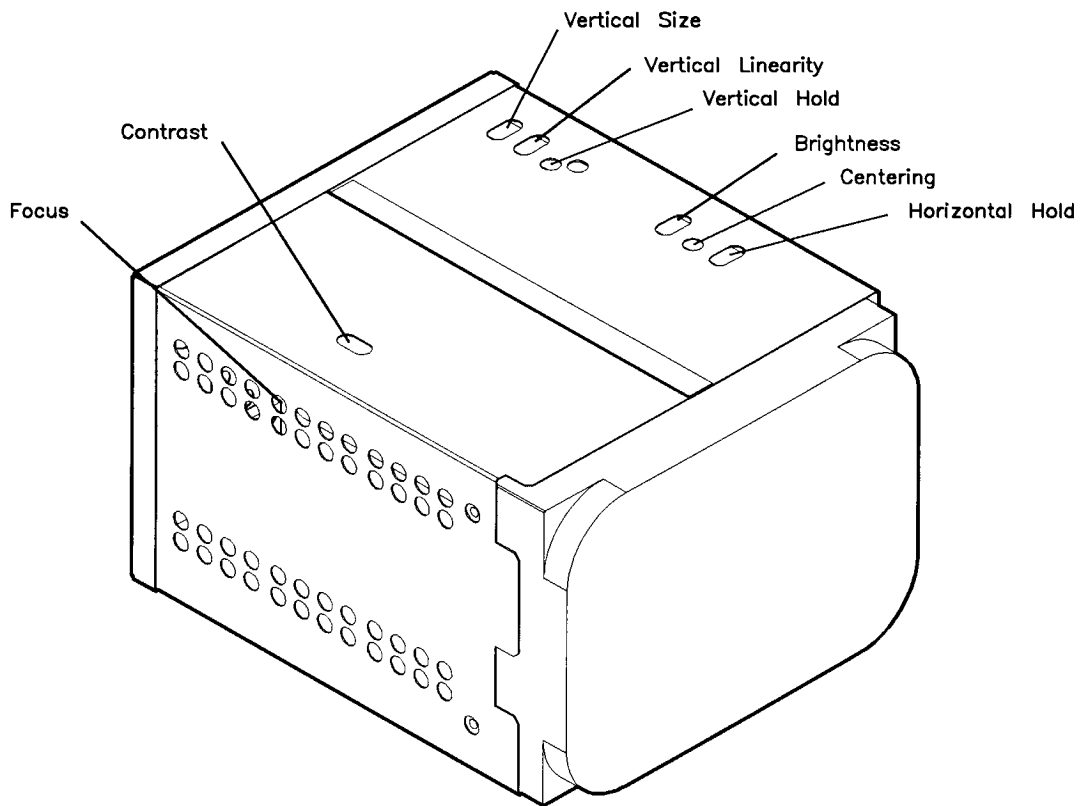
## 1b. Display (with eight access holes in top of shield)

### Centering

*Perform this adjustment only if the displayed image is not horizontally centered on the display.*

The Centering potentiometer is accessible through the top of the display's cover. The instrument cover must be removed for access to the display's cover. Refer to Figure 2-4 for the location of this adjustment. Use the specified adjustment tool to make this adjustment.

1. Press **CAL** More 1 of 4 CRT HORZ POSITION.
2. Set the CRT horizontal position setting to 12.
3. Set the Centering potentiometer so the displayed image is positioned approximately at the center of the display.



dispadj

**Figure 2-4. Display Adjustment Locations**

## 1b. Display (with eight access holes in top of shield)

### Horizontal Hold

*Perform this adjustment only if the displayed image is rolling horizontally across the display.*

The Horizontal Hold potentiometer is accessible through the top of the display's cover. The instrument cover must be removed for access to the display's cover. Refer to Figure 2-4 for the location of this adjustment. Use the specified adjustment tool to make this adjustment.

1. If the display is unreadable, first adjust the Horizontal Hold potentiometer for a stable display.
2. Press **CAL** More 1 of 4 CRT HORZ POSITION .
3. Set the CRT horizontal position setting to 12.
4. Find the clockwise position of the Horizontal Hold potentiometer where the display begins to roll horizontally.
5. Find the counter-clockwise position of the Horizontal Hold potentiometer where the display begins to roll horizontally.
6. Set the adjustment to a position approximately midway between the clockwise and counter clockwise position where the display does not roll horizontally.

### Vertical Hold

*Perform this adjustment only if the displayed image is rolling vertically on the display.*

The Vertical Hold potentiometer is accessible through the top of the display's cover. The instrument cover must be removed for access to the display's cover. Refer to Figure 2-4 for the location of this adjustment. Use the specified adjustment tool to make this adjustment.

1. If the display is unreadable, first adjust the Vertical Hold potentiometer for a stable display.
2. Press **CONFIG** More 1 of 3 More 2 of 3 .
3. Press **SYNC NRM NTSC** (NTSC).
4. Adjust the Vertical Hold potentiometer so that the display image is not rolling vertically.
5. Press **SYNC NRM PAL** (PAL).
6. Adjust the Vertical Hold potentiometer so that the display image is not rolling vertically.
7. Repeat steps 2 through 5 until no adjustment is necessary for either the NTSC or the PAL mode.
8. Press **DEFAULT SYNC** .

This is the third softkey from the top.



## 1b. Display (with eight access holes in top of shield)

### Vertical Size

*Perform this adjustment only if the displayed image is too tall or too short for the display.*

The Vertical Size potentiometer is accessible through the top of the display's cover. The instrument cover must be removed for access to the display's cover. Refer to Figure 2-4 for the location of this adjustment. Use the specified adjustment tool to make this adjustment.

1. Press **CAL** More 1 of 4 CRT VERT POSITION.
2. Set the CRT vertical position setting so that softkey labels are adjacent to the keys at the right to which they are associated.
3. Adjust the Vertical Size potentiometer so that the uppermost softkey label is adjacent to the uppermost softkey and the lowermost softkey label is adjacent to the lowermost softkey.
4. Repeat steps 2 and 3 if necessary.

### Vertical Linearity

*Perform this adjustment only if the vertical space between the horizontal graticules are not equal on the display.*

The Vertical Linearity potentiometer is accessible through the top of the display's cover. The instrument cover must be removed for access to the display's cover. Refer to Figure 2-4 for the location of this adjustment. Use the specified adjustment tool to make this adjustment.

- Adjust the Vertical Linearity potentiometer so that the vertical space between each of horizontal graticules are approximately equal.

### Brightness and Contrast

*Perform these adjustments only if the brightness and contrast of the display is not correct.*

The Brightness and Contrast potentiometers are accessible through the top of the display's cover. The instrument cover must be removed for access to the display's cover. Refer to Figure 2-4 for the locations of these adjustments. Use the specified adjustment tool to make these adjustments.

The Brightness and Contrast potentiometers are interactive adjustments.

1. Adjust the Contrast potentiometer to the full clockwise position (the image is no longer displayed).
2. Adjust the front-panel *INTEN* knob to the full clockwise position.
3. Adjust the Bright potentiometer until the background is just barely extinguished (the background is dark).
4. Adjust the front-panel *INTEN* knob to the full counter-clockwise position.
5. Adjust the Contrast potentiometer until the image is just barely extinguished.
6. Adjust the front-panel *INTEN* knob to the full clockwise position and verify there is not background illumination. If necessary, re-adjust brightness and contrast so that the front-panel *INTEN* will go from a dark screen to a bright screen with a dark background.
7. Adjust the front-panel *INTEN* knob for comfortable brightness and adjust the display focus.

---

## 2. Sampler Match

### This adjustment applies to:

All HP 8590 E-Series and L-Series spectrum analyzers  
HP 8591C cable TV analyzers  
HP 8594Q QAM analyzers

The match between the sampling oscillator and the sampler is optimized by first setting the sampling-oscillator frequency for midrange, then adjusting the sampler-match adjustment for maximum dc volts as read on a digital multimeter.

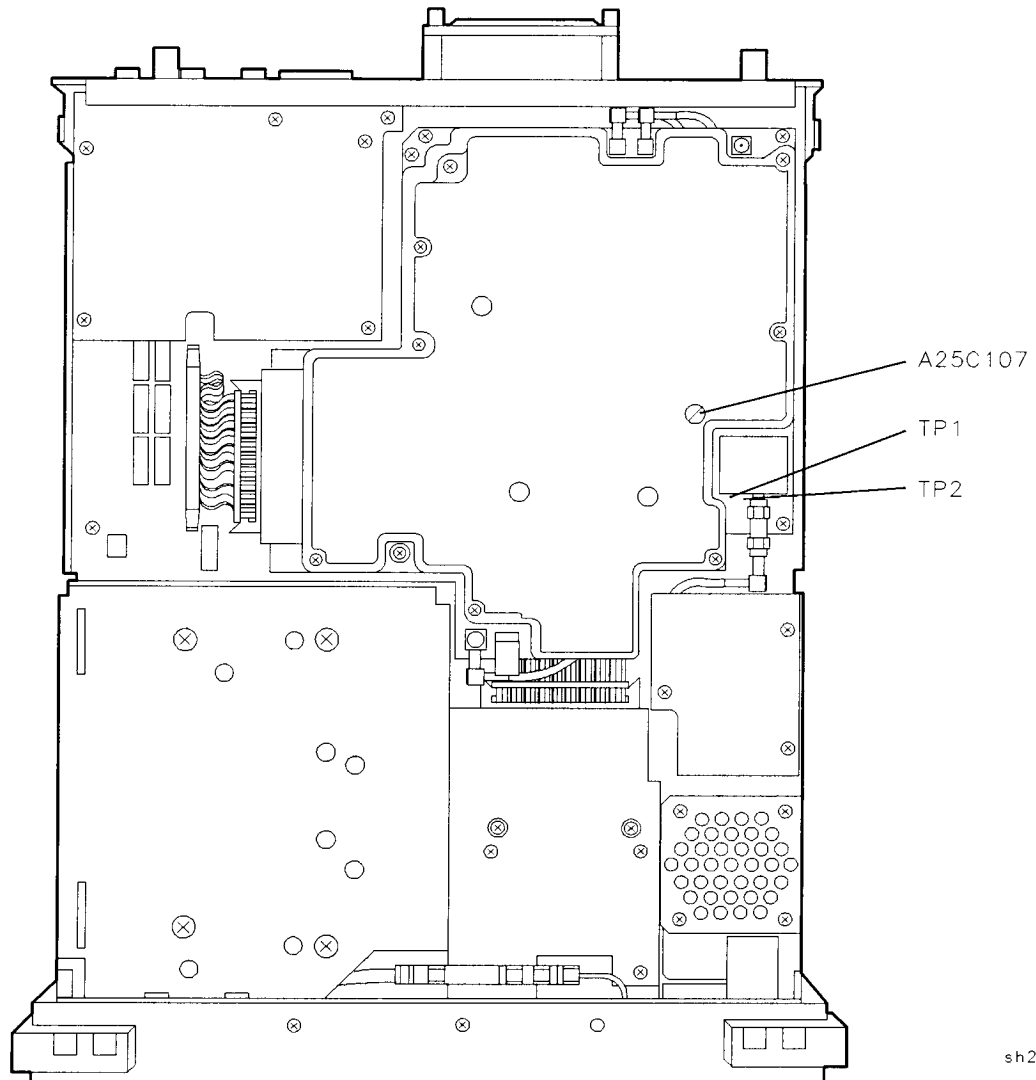
### Equipment Required

Digital multimeter  
DMM test leads

### Procedure

1. Turn the analyzer **LINE** switch to OFF. Remove the instrument over assembly.
2. Turn the analyzer **LINE** switch to ON.
3. Set the center frequency of the analyzer to 194 MHz. If you are adjusting an HP 8590L, or HP 8591E spectrum analyzer, or an HP 8591C cable TV analyzer, set the center frequency to 265 MHz.
4. Press the following analyzer keys.  
**SPAN** 10 **MHz**
5. Connect the digital multimeter (DMM) from chassis ground to A25TP1. Refer to Figure 2-5.
6. Adjust A25C107 for maximum voltage as read on the DMM. This voltage must be  $-1.5\text{ V} \pm 1.0\text{ V}$ .
7. Measure the voltage at A25TP2. It should be  $+1.5\text{ V} \pm 1.0\text{ V}$ . If it is not, readjust A25C107 until a compromise is established between the two test points, such that the voltage specifications of steps 6 and 7 are met.

## 2. Sampler Match



**Figure 2-5. A25 Counter Lock Assembly Test Points**

sh223e

---

### 3. 10 MHz Reference

**This adjustment applies to:**

- All HP 8590 E-Series and L-Series spectrum analyzers
- HP 8591C cable TV analyzers with Option 704
- HP 8594Q QAM analyzers with Option 704

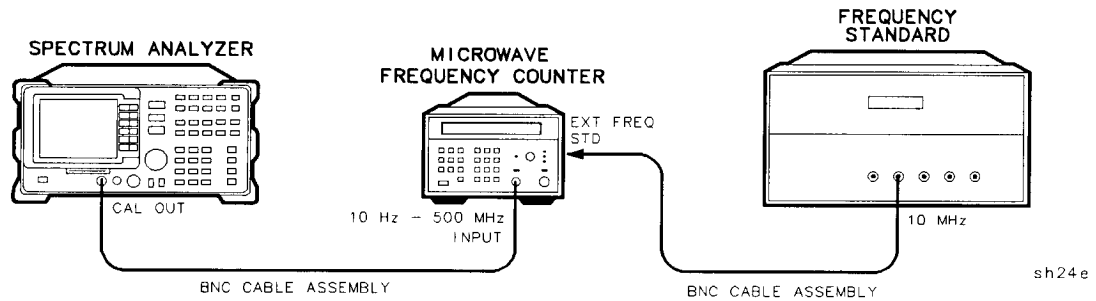
The internal 10 MHz time base is adjusted for frequency accuracy. This procedure does not adjust for long-term drift or aging rate. Only short-term accuracy is adjusted.

A frequency counter is connected to the CAL OUT, which is locked to the 10 MHz reference. This yields better effective resolution.

The time base is adjusted for a frequency of 300 MHz as read by the frequency counter.

#### Equipment Required

- Microwave frequency counter
- Frequency standard
- Cable, 122 cm (48 in) (*two required*)



**Figure 2-6. 10 MHz Reference Adjustment Setup**

**Procedure**

Note that to properly adjust the time base, a frequency standard with a better time base accuracy than that of the analyzer is required.

1. Connect the equipment as shown in Figure 2-6.

2. Set the microwave frequency counter controls as follows:

50 Ω/1 MΩ .....	50 Ω Impedance
10 Hz–500 MHz/500 MHz–18 GHz .....	10 Hz–500 MHz
SAMPLE RATE .....	Midrange
FREQUENCY STANDARD .....	EXTERNAL

3. Press the following analyzer keys.

```

PRESET
FREQUENCY -2001 Hz
CAL More 1 of 4 More 2 of 4 More 3 of 4 SERVICE CAL CAL TIMEBASE
    
```

4. A number will be displayed in the active function block of the analyzer display. This is the setting of the DAC (0 to 255) which controls the frequency of the internal time base. Use the knob or keyboard to change the DAC setting until the frequency counter reads 300 MHz ±75 Hz (±0.25 ppm).

5. Once the time base has been adjusted for minimum deviation from 300 MHz, press CAL STORE. The new DAC number is now stored in nonvolatile memory.

## 4. 10 MHz Precision Frequency Reference

This adjustment applies to:

All HP 8590 E-Series spectrum analyzers, Option 004  
HP 8591C cable TV analyzers  
HP 8594Q QAM analyzers

Replacement oscillators are factory adjusted after a complete warmup and after the specified aging rate has been achieved. Readjustment should not be necessary after oscillator replacement, and is not recommended.

Note that the analyzer must be ON continuously for at least 24 hours immediately prior to adjusting the oscillator to allow both the temperature and frequency of the oscillator to stabilize. Failure to allow sufficient stabilization time could result in the misadjustment of the oscillator.

The frequency of the internal 10 MHz frequency reference is compared to a known frequency standard and adjusted for minimum frequency error. This procedure does not adjust the short-term stability or long-term stability of the 10 MHz Ovenized Crystal Oscillator (OCXO), which are determined by characteristics of the particular oscillator and the environmental and warmup conditions to which it has been recently exposed. The analyzer must be ON continuously for at least 24 hours immediately prior to oscillator adjustment to allow both the temperature and frequency of the oscillator to stabilize.

### Equipment Required

Frequency standard  
Frequency counter  
Cable, BNC, 122 cm (48 in) (*two required*)

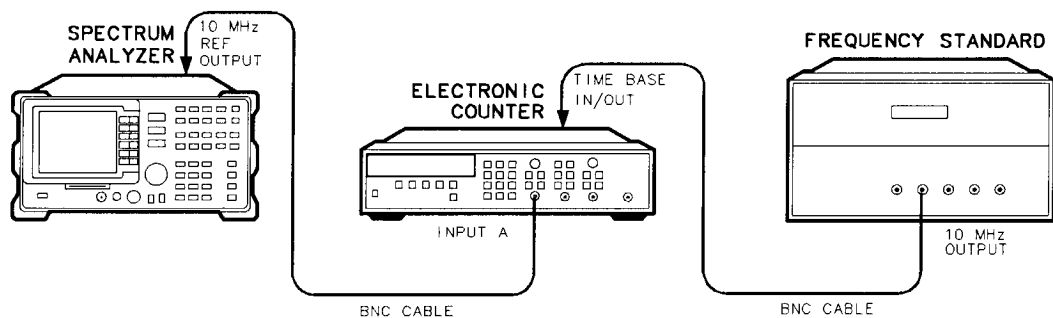


Figure 2-7. Precision Frequency Reference Setup

**Procedure**

1. Place the analyzer on its side as shown in Figure 2-7 and set the LINE switch of the analyzer to ON.
2. Allow the analyzer to remain powered ON and undisturbed for at least 24 hours, so that both the temperature and frequency of the OCXO can stabilize.
3. Connect the frequency standard to the frequency counter rear-panel TIMEBASE IN/OUT connector. Refer to Figure 2-7.
4. Disconnect the jumper between the 10 MHz REF OUTPUT and EXT REF IN jacks on the analyzer rear panel. Connect a BNC cable between the 10 MHz REF OUTPUT jack and INPUT A on the frequency counter.
5. Set the frequency counter controls as follows:

```

FUNCTION/DATA ..... FREQ A
INPUT A:
  x10 ATTN ..... OFF
  AC ..... OFF (DC coupled)
  50 Ω Z ..... OFF (1 MΩ input impedance)
  AUTO TRIG ..... ON
  100 kHz FILTER A ..... OFF
  INT/EXT switch (rear panel) ..... EXT
    
```

6. On the frequency counter select a 1 second gate time and a 10 MHz offset of the displayed frequency by pressing the following frequency counter keys.

```

[GATE TIME] 1 [GATE TIME]
MATH [SELECT/ENTER]
[CHS/EEX] 10 [CHS/EEX] 6 [SELECT/ENTER]
[SELECT/ENTER]
    
```

The frequency counter should now display the difference between the frequency of the INPUT A signal and 10.0 MHz with a displayed resolution of 10 MHz (0.010 Hz).

7. Locate the FREQ ADJ control on the OCXO. See Figure 2-8. Remove the dust cap screw.
8. Use a nonconductive adjustment tool to adjust the FREQ ADJ control on the OCXO for a frequency counter indication of 0.00 Hz.
9. Select a 10 second gate time by pressing the following frequency counter keys.

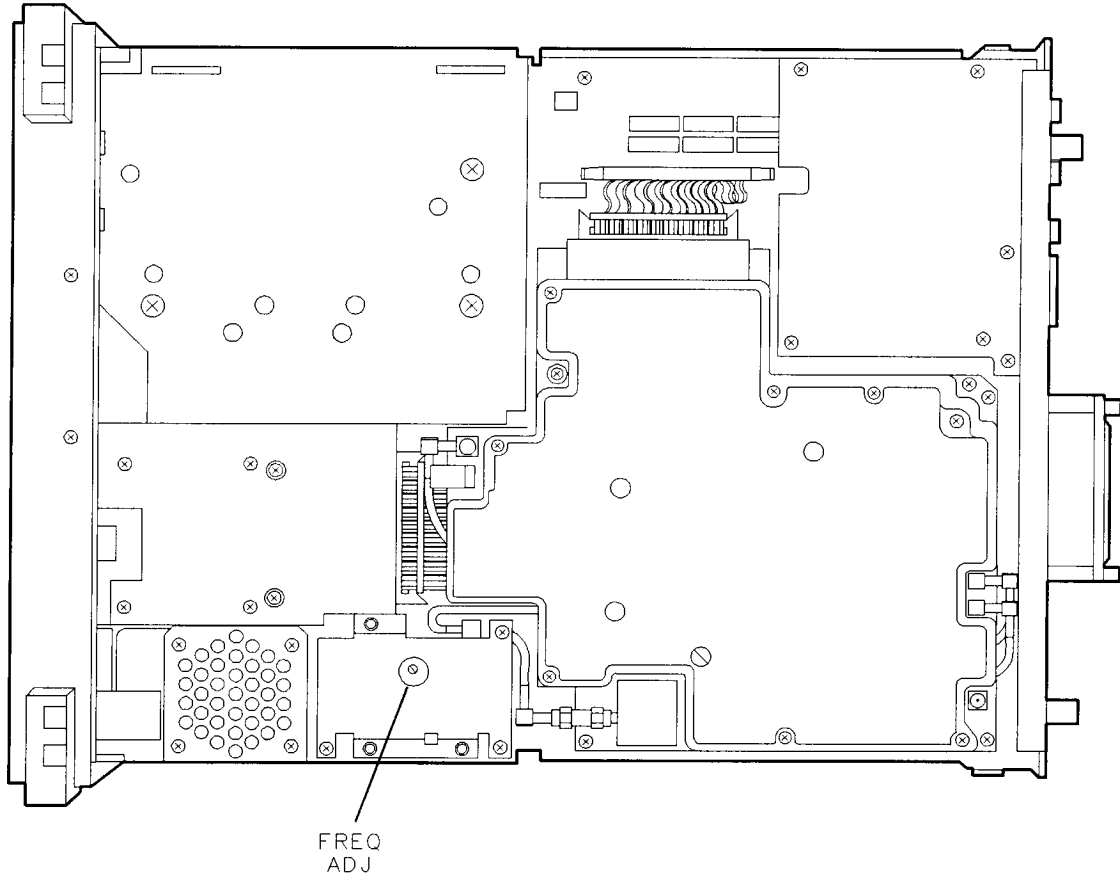
```

[GATE TIME] 10 [GATE TIME]
    
```

The frequency counter should now display the difference between the frequency of the INPUT A signal and 10.0 MHz with a resolution of 0.001 Hz (1 MHz).

10. Wait at least 2 gate periods for the frequency counter to settle, and then adjust the FREQ ADJ control on the OCXO for a stable frequency counter indication of 0.000 ±0.010 Hz.
11. Replace the dust cap screw on the OCXO.

#### 4. 10 MHz Precision Frequency Reference



sh224e

**Figure 2-8. Oven Reference Adjustment Location**



---

## 5. Crystal and LC Bandwidth Filter

### This adjustment applies to:

All HP 8590 E-Series and L-Series spectrum analyzers  
HP 8591C cable TV analyzers  
HP 8594Q QAM analyzers

The crystal and LC bandwidth filter circuits are adjusted for symmetry, center frequency, and peak amplitude.

First, correction constants are turned off. This allows for uncorrected 3 dB resolution bandwidth centering and amplitude adjustments.

New corrections are then generated by performing the CAL FREQ and CAL AMPD adjustment routines.

### Equipment Required

Crystal shorts (*set of three*)  
Cable, BNC, 23 cm (9 in)

### Additional Equipment for 75 $\Omega$ Input

Cable, BNC, 75  $\Omega$ , 30 cm (12 in)

### Procedure

1. Turn the analyzer **LINE** switch to OFF. Remove the instrument cover assembly.
2. Turn the analyzer **LINE** switch to ON, then press the following analyzer keys.

**PRESET**

**CAL** More 1 of 4

**CORRECT ON OFF** (OFF)

### Crystal Alignment

---

**Caution** Use only 75  $\Omega$  cables, connectors, or adapters on instruments equipped with 75  $\Omega$  inputs or damage to the input connectors will occur.

---

3. Connect the CAL OUT to the INPUT 50  $\Omega$  with the BNC cable.

*75  $\Omega$  input:* Connect the CAL OUT to the INPUT 75  $\Omega$  with the 75  $\Omega$  BNC cable.

## 5. Crystal and LC Bandwidth Filter

4. Press the following analyzer keys.

FREQUENCY 300 MHz  
SPAN 10 MHz  
PEAK SEARCH  
MKR FCTN MK TRACK ON OFF (ON)

75  $\Omega$  input: AMPLITUDE More 1 of 2 AMPTD UNITS dBm

SPAN 200 kHz  
AMPLITUDE 20 -dBm  
SCALE LOG LIN (LIN)  
More 1 of 2 AMPTD UNITS dBm  
BW 3 kHz

5. Press AMPLITUDE, then use the knob to place the signal at the sixth graticule line from the bottom.
6. Press BW 30 kHz on the analyzer.

---

**Caution** Shorting the crystal test points to ground may permanently damage the bandwidth board assembly. If you make your own shorts, it is advisable to insulate the bare wires and connectors.

---

7. Connect the crystal shorts (through the access holes on the assembly cover) across the following pairs of test points.

A13TP1 and A13TP2  
A11TP1 and A11TP2  
A11TP4 and A11TP5

8. Adjust A13C54 CTR for minimum signal amplitude. Then adjust A13C38 SYM and A13C54 CTR for a centered and symmetrical bandpass response as shown in Figure 2-9.

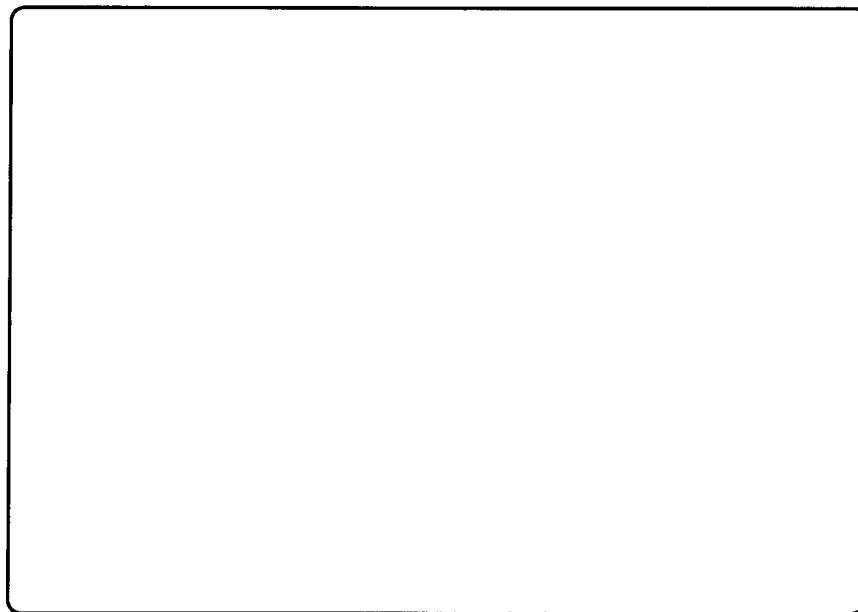


Figure 2-9. Crystal Symmetry and Centering

## 5. Crystal and LC Bandwidth Filter

9. Remove the crystal short from A13TP1 and A13TP2 and connect it across A13TP4 and A13TP5.
10. Adjust A13C25 CTR for minimum signal amplitude. Then adjust A13C15 SYM and A13C25 CTR for a centered and symmetrical bandpass response.
11. Remove the crystal short from A11TP4 and A11TP5. Connect the short across A13TP1 and A13TP2.
12. Adjust A11C54 CTR for minimum signal amplitude. Then adjust A11C38 SYM and A11C54 CTR for a centered and symmetrical bandpass response.
13. Remove the crystal short from A11TP1 and A11TP2. Connect the short across A11TP4 and A11TP5.
14. Adjust A11C25 CTR for minimum signal amplitude. Then adjust A11C15 SYM and A11C25 CTR for a centered and symmetrical bandpass response.
15. Remove the crystal shorts and press the following analyzer keys.

**PEAK SEARCH**

**MKR FCTN MK TRACK ON OFF (ON)**

**SPAN 50 (kHz)**

**MKR FCTN MK TRACK ON OFF (OFF)**

**BW 3 (kHz)**

**PEAK SEARCH MARKER DELTA**

**BW 30 (kHz)**

**PEAK SEARCH**

16. Verify that the MARKER  $\Delta$  frequency does not exceed 3 kHz.  
If the signal shift is out of tolerance, repeat steps 3 through 16.
17. Press the following analyzer keys.

**MKR**

**MARKER 1 ON OFF (OFF)**

## 5. Crystal and LC Bandwidth Filter

### LC Alignment

18. Press the following analyzer keys.

**BW** 100 **kHz**  
**SPAN** 5 **MHz**

19. Widen all but one of the LC filter poles by shorting A11TP10 and A11TP11, A11TP12 and A11TP13, and A13TP10 and A13TP11 using the crystal shorts.

---

#### Caution

Use a tool with a nonmetallic body to make the LC dip adjustment.

Shorting components to ground may result in permanent damage to the bandwidth board assembly.

---

20. Center the signal on the analyzer display by pressing the following analyzer keys.

**PEAK SEARCH**  
**MKR FCTN** MK TRACK ON OFF (ON)

21. Adjust A13C47 LC dip for a minimum signal amplitude.
22. Move the short from A13TP10 and A13TP11 to A13TP12 and A13TP13, then adjust A13C17 LC dip for a minimum signal amplitude.
23. Move the short from A11TP10 and A11TP11 to A13TP10 and A13TP11, then adjust A11C17 LC dip for a minimum signal amplitude.
24. Move the short from A11TP12 and A11TP13 to A11TP10 and A11TP11, then adjust A11C47 LC dip for a minimum signal amplitude.

### LC Centering

Note that the center frequency of the 100 kHz bandwidth is referenced to the 30 kHz bandwidth. During this procedure it is advisable to switch to the 30 kHz bandwidth occasionally and recenter it using **PEAK SEARCH** **MARKER** → **CF**.

25. Short A11TP10 and A11TP11, A11TP12 and A11TP13, and A13TP10 and A13TP11 using the crystal shorts used in the crystal alignment section. Press the following analyzer keys.

**BW** 30 **kHz**  
**SPAN** 200 **kHz**  
**MKR FCTN** MK TRACK ON OFF (OFF)  
**BW** 100 **kHz**

26. Adjust A11C45 LC CTR for maximum signal at center-screen.
27. Move the short from A11TP10 and A11TP11 to A11TP12 and A11TP13, then adjust A11C23 LC CTR for maximum signal at center-screen.
28. Move the short from A13TP12 and A13TP13 to A11TP10 and A11TP11, then adjust A13C45 LC CTR for maximum signal at center-screen.
29. Move the short from A13TP10 and A13TP11 to A13TP12 and A13TP13, then adjust A13C23 LC CTR for maximum signal at center-screen.
30. Disconnect all the shorts from A11 and A13 bandwidth board assemblies.

### LC Amplitude

31. Press the following analyzer keys.

**BW** 3 **MHz**  
**SPAN** 2 **MHz**

32. Press **AMPLITUDE** and adjust the signal level one division below the top graticule using the knob.
33. Press the following analyzer keys.

**PEAK SEARCH** **MARKER Δ**  
**MKR FCTN** **MK TRACK ON OFF (ON)**  
**BW** 100 **kHz**

It may be necessary to occasionally recenter the 30 kHz bandwidth.

34. Adjust A11R26 LC and A13R26 LC equally for a **MARKER Δ** amplitude of 0 dB. Each potentiometer should be adjusted to accomplish one-half of the necessary increase in signal amplitude. If A11R26 or A13R26 reaches its limit, recenter both potentiometers and repeat steps 31 through 35.
35. Press **MKR FCTN**, **MK TRACK ON OFF (OFF)** on the analyzer.

### Final LC Centering

36. Press the following analyzer keys.

**BW** 30 **kHz**  
**SPAN** 100 **kHz**  
**PEAK SEARCH** **MARKER → CF**  
**BW** 100 **kHz**

37. Make final adjustments by adjusting A11C23, A11C45, A13C23, and A13C45 in succession to peak the amplitude of the marker at center-screen.
38. Repeat steps 36 and 37 until the 30 kHz and 100 kHz bandwidths are centered in relation to each other.
39. Press the following analyzer keys.

**BW** 30 **kHz**  
**PEAK SEARCH**  
**MARKER Δ**  
**BW** 100 **kHz**  
**PEAK SEARCH**

40. Verify that the **MARKER Δ** frequency does not exceed 10 kHz.  
 If the signal shift is out of tolerance, repeat steps 26 through 39.

## 5. Crystal and LC Bandwidth Filter

### Crystal Amplitude

41. Press the following analyzer keys.

**BW** 30 **(kHz)**

**SPAN** 10 **(kHz)**

**PEAK SEARCH**

**MARKER**  $\Delta$

**MKR FCTN** **MK TRACK ON OFF (ON)**

**BW** 1 **(kHz)**

42. Adjust A11R31 XTL and A13R31 XTL equally for a MARKER  $\Delta$  amplitude reading of 0 dB. Each potentiometer should be adjusted to accomplish one-half of the necessary increase in signal amplitude. If A11R31 or A13R31 reaches its limit, recenter both potentiometers and repeat steps 41 and 42.

### Final BW Amplitude Check

43. Run the "CAL FREQ Adjustment Routine" and the "CAL AMPTD Adjustment Routine."

44. Remember to press **CAL STORE** after the completion of the routines to store data in nonvolatile memory.

45. Press the following analyzer keys to verify that the bandwidth amplitude corrections are within specifications.

**CAL** More 1 of 4 More 2 of 4

**SERVICE DIAG**

**DISPLAY CAL DATA**

## 5. Crystal and LC Bandwidth Filter

46. Refer to the BW-AMP column of the analyzer display to locate the XTAL and LC bandwidth amplitude-correction numbers of the analyzer. All LC and XTAL bandwidth readings should be between  $-0.8$  dB to  $+0.5$  dB. Table 2-3 describes and shows an example of the XTAL and LC bandwidth amplitude-correction numbers that will be displayed on the analyzer. Perform the following steps that apply to your analyzer.
- If the difference between the bandwidth amplitude-correction numbers of the 30 kHz XTAL and 3 MHz LC is greater than 0.8 dB, pad A11R8 or A13R8 and repeat the Final BW Amplitude Check. Refer to the Component-Level Information Package for the location of A11R8 and A13R8.
  - If the 30 kHz XTAL bandwidth amplitude correction is greater than the 3 MHz LC bandwidth correction, increase the value of A11R8 or A13R8.
  - If the 3 MHz LC bandwidth amplitude correction is greater than the 30 kHz XTAL bandwidth correction, decrease the value of A11R8 or A13R8.
  - If just the 100 kHz LC amplitude is out of range, repeat steps 23 through 38 and steps 43 through 46.
  - If the 1 kHz XTAL amplitude is out of the above range, repeat steps 41 through 46.

**Table 2-3. Bandwidth Amplitude-Correction Map**

<b>Resolution Bandwidths</b>	<b>BW-AMP Correction Numbers</b>
not used	0.00
not used	0.00
not used	0.00
not used	0.00
XTAL: 9 kHz	0.00
300 Hz	0.46
1 kHz	0.06
3 kHz	-0.02
10 kHz	0.00
30 kHz	0.00
LC: 100 kHz	-0.27
300 kHz	-0.40
1 MHz	-0.43
3 MHz	-0.47
5 MHz	-0.54
120 kHz	-0.17

---

## 6. Cal Attenuator Error

### This adjustment applies to:

All HP 8590 E-Series and L-Series spectrum analyzers  
HP 8591C cable TV analyzers  
HP 8594Q QAM analyzers

The A12 amplitude control assembly has one 10 dB and two 20 dB nonadjustable amplifiers. It also has 1 dB, 2 dB, 4 dB, 8 dB, and 16 dB attenuators which are correctable. The 16 dB step is not used at this time.

The attenuator error correction procedure involves disabling the attenuator correction constants, determining the attenuator step errors, and entering the new correction constants into the analyzer memory.

### Equipment Required

Synthesizer/level generator  
Cable, BNC, 120 cm (48 in)  
Adapter, Type N (m) to BNC (f)

### Additional Equipment for Option 026

Adapter, Type BNC (f) to SMA (m)

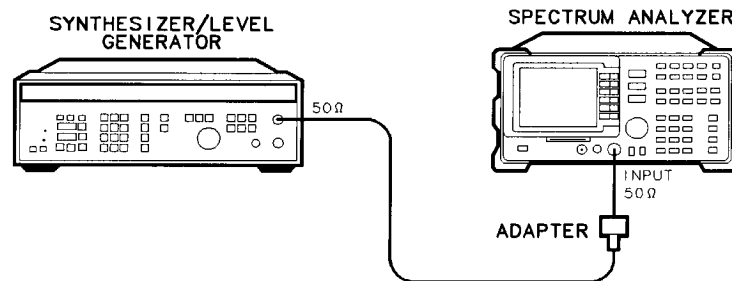
### Additional Equipment for 75 $\Omega$ Input

Cable, BNC, 75  $\Omega$ , 120 cm (48 in)

---

**Caution** Use only 75  $\Omega$  cables, connectors, or adapters on instruments equipped with 75  $\Omega$  inputs or damage to the input connectors will occur.

---



sh26e

Figure 2-10. Cal Attenuator Error Correction Setup



## Procedure

The accuracy of the amplitude control attenuator is critical to the proper calibration of the instrument; therefore, this procedure must be carefully and accurately performed.

1. Turn the analyzer **LINE** switch to OFF. Remove the instrument cover assembly.
2. Turn the analyzer **LINE** switch to ON.
3. Connect the 50  $\Omega$  output of the synthesizer/level generator to the analyzer INPUT 50  $\Omega$ . See Figure 2-10.

*75  $\Omega$  input:* Connect the 75  $\Omega$  output of the synthesizer/level generator to the analyzer INPUT 75  $\Omega$ .

4. Set the frequency of the synthesizer/level generator to 25 MHz and the output to  $-19$  dBm.
5. To turn the amplitude attenuator correction constants off, press the following analyzer keys.

```

PRESET
CAL More 1 of 4
CORRECT ON OFF (OFF)
  
```

## 1 dB Step Check

6. To measure the 1 dB step correction, press the following analyzer keys.

```

FREQUENCY 25 MHz
SPAN 10 MHz
  
```

*75  $\Omega$  input:* **AMPLITUDE** More 1 of 2 **AMPTD UNITS** dBm

```

AMPLITUDE 18 -dBm
SCALE LOG LIN (LIN) More 1 of 2
AMPTD UNITS dBm
PEAK SEARCH
MKR FCTN MK TRACK ON OFF (ON)
SPAN 50 kHz
BW 3 kHz
VID BW AUTO MAN 300 Hz
  
```

7. Press the following analyzer keys.

```

PEAK SEARCH MARKER DELTA
MKR FCTN MK TRACK ON OFF (ON)
  
```

8. The MKR  $\Delta$  amplitude reading should be  $0.0 \text{ dB} \pm 0.01 \text{ dB}$ . If it is not, repeat step 7.
9. Set the analyzer by pressing **AMPLITUDE** 17 **-dBm**.
10. Set the amplitude of the synthesizer/level generator to  $-18$  dBm.
11. Press **MKR** on the analyzer.
12. Record the MKR  $\Delta$  amplitude reading in Table 2-4. This is the 1 dB attenuator step error of the A12 amplitude control assembly.

## 6. Cal Attenuator Error

### 2 dB Step Check

13. Press the following analyzer keys.

**AMPLITUDE** 16 **-dBm**.

14. Set the amplitude of the synthesizer/level generator to -17 dBm.

15. Press the following analyzer keys.

**PEAK SEARCH**

**MARKER DELTA MARKER DELTA**

**MKR FCTN** **MK TRACK ON OFF (ON)**

16. MKR  $\Delta$  amplitude reading should be  $0.0 \pm 0.01$ . If it is not, repeat step 15.

17. Set the analyzer by pressing **AMPLITUDE** 14 **-dBm**.

18. Set the amplitude of the synthesizer/level generator to -15 dBm.

19. Press **MKR** on the analyzer.

20. Record the MKR  $\Delta$  amplitude reading in Table 2-4. This is the 2 dB attenuator step error of the A12 amplitude control assembly.

### 4 and 8 dB Step Error

21. Repeat steps 13 through 20 for attenuator steps 4 dB and 8 dB. Use Table 2-4 for synthesizer values and analyzer reference-level values.

**Table 2-4. A12 Amplitude Control Assembly Attenuator Errors**

Synthesizer Settings (dBm)		Reference Level Settings (dBm)		Attenuator Step (dB)	Error
Attenuator OFF	Attenuator ON	Attenuator OFF	Attenuator ON		
-19	-18	-18	-17	1	_____
-17	-15	-16	-14	2	_____
-18	-14	-17	-13	4	_____
-19	-11	-18	-10	8	_____

## Entering Attenuator Error Correction Data

22. Press the following analyzer keys.

**PRESET**

75  $\Omega$  input: **AMPLITUDE** More 1 of 2 **AMPTD UNITS** dBm

**FREQUENCY** -2001 **Hz**

**CAL** More 1 of 4 More 2 of 4

**SERVICE CAL SET ATTN ERROR**

Note that the frequency of -2001 **Hz** is necessary to access the **SERVICE CAL** routines.

23. When the analyzer prompts you with the message **ENTER CAL ATTN ERROR**, enter the data from Table 2-4 and terminate with the reverse sign using the **dBm** or **-dBm** keys. For example, if the error recorded in Table 2-4 is 0.07, enter 0.07 and terminate with **-dBm**.
24. When the analyzer prompts you to enter the 16 dB step, enter 0 dBm. At the completion of entering the 16 dB error, the analyzer will reset.
25. To confirm that the correct data is stored, access the cal attenuator corrections by pressing the following analyzer keys.

**CAL** More 1 of 4 More 2 of 4

**SERVICE DIAG**

**DISPLAY CAL DATA**

Note that the cal-attenuator correction data are the first five corrections located in the **ERR** column.

## 7. Log and Linear Amplifier

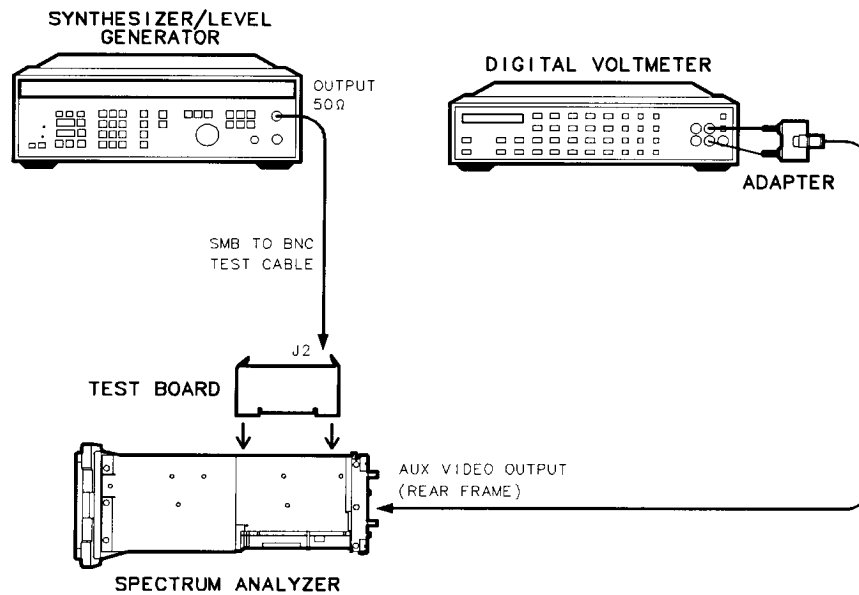
This adjustment applies to:

All HP 8590 E-Series and L-Series spectrum analyzers  
HP 8591C cable TV analyzers  
HP 8594Q QAM analyzers

A 21.4 MHz signal is injected into an IF test board that has been inserted in place of the first resolution bandwidth assembly, A11. The gain of the A14 log amplifier assembly is adjusted by observing the voltage at the AUX VIDEO OUT on the rear panel with a digital multimeter.

### Equipment Required

Synthesizer/level generator  
Digital multimeter (DMM)  
IF test board  
Cable, BNC, 120 cm (48 in)  
Cable, BNC (f) to dual banana plug  
Test cable



sh27e

Figure 2-11. Log and Linear Amplifier Adjustment Setup

**Procedure**

1. Turn the analyzer **LINE** switch to OFF. Remove the instrument cover assembly.
2. Remove the first IF bandwidth filter assembly, A11. Install the IF test board into the A11 slot. Turn the analyzer **LINE** switch to ON.
3. Set the DMM to read dc volts.
4. Press the following analyzer keys.

```

PRESET
CAL More 1 of 4
CORRECT ON OFF (OFF) More 2 of 4
SERVICE DIAG
STP GAIN ZERO
SPAN 0 Hz
BW 10 kHz
VID BW AUTO MAN 300 Hz
AMPLITUDE 10 -dBm
SCALE LOG LIN (LIN)
    
```

5. Set the synthesizer as follows:

```

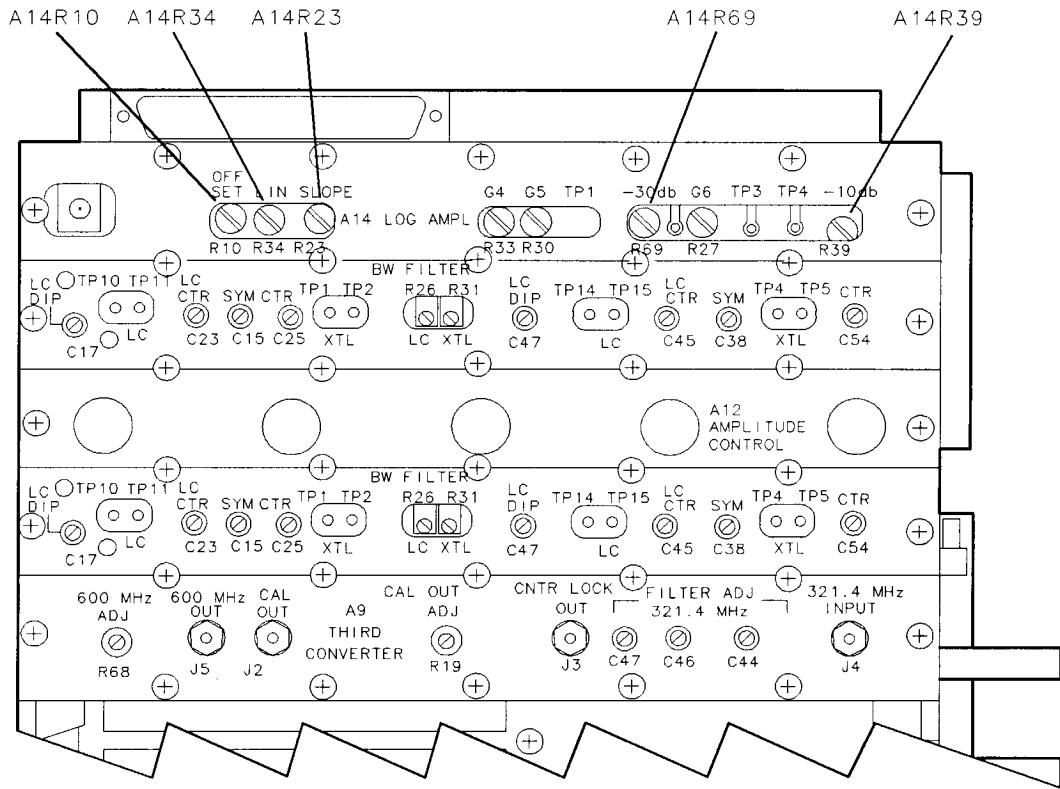
FREQUENCY ..... 21.4 MHz
MANUAL TUNE ..... ON
AMPTD INCR ..... 0.01 dBm
AMPLITUDE ..... -6 dBm
    
```

6. Connect equipment as shown in Figure 2-11. Connect the output of the synthesizer to J2 of the IF test board. Connect the DMM to AUX VIDEO OUT (located on the rear panel).

**Log Fidelity Adjustment**

7. Adjust the synthesizer knob for maximum signal amplitude on the display. Adjust the synthesizer amplitude as necessary to keep the signal on the display.
8. Adjust the synthesizer output level for a DMM reading of 1000 mV  $\pm$ 1.0 mV. Record the synthesizer amplitude readout for later reference: \_\_\_\_\_ **dBm**.
9. Press AMPTD INCR 10 dB on the synthesizer.
10. Press **SCALE** (LOG) on the analyzer.
11. Set the synthesizer to the level recorded in step 8 and adjust A14R23 SLOPE (refer to Figure 2-12) for a DMM reading of 1000 mV  $\pm$ 1 mV.

## 7. Log and Linear Amplifier



sh225e

**Figure 2-12. Log and Linear Amplifier Adjustment Location**

12. Set the synthesizer amplitude 60 dB below that recorded in step 8 by pressing AMPLITUDE and then pressing STEP DOWN six times. Adjust A14R10 OFFSET for the DMM reading of  $250 \text{ mV} \pm 1 \text{ mV}$ .
13. Repeat steps 11 and 12 until no further adjustment is necessary.
14. Set the synthesizer amplitude 30 dB below that recorded in step 8 and adjust the A14R23 SLOPE for a DMM reading of  $625 \text{ mV} \pm 1 \text{ mV}$ .
15. Set the synthesizer amplitude to the level recorded in step 8 and adjust the A14R69 -30 dB for a DMM reading of  $1000 \text{ mV} \pm 1 \text{ mV}$ .
16. Repeat steps 14 and 15 until no further adjustment is necessary.
17. Set the synthesizer amplitude 10 dB below that recorded in step 8 and adjust the A14R23 SLOPE for a DMM reading of  $875 \text{ mV} \pm 1 \text{ mV}$ .
18. Set the synthesizer amplitude to the level recorded in step 8 and adjust the A14R39 -10 dB for a DMM reading of  $1000 \text{ mV} \pm 1 \text{ mV}$ .
19. Repeat steps 17 and 18 until no further adjustment is necessary.
20. Repeat steps 11 through 19 until the limits in Table 2-5 are met.

Table 2-5. Log Fidelity Check

Synthesizer Level	DMM Reading
Reference from step 8	1000 mV $\pm$ 1 mV
Reference – 10 dB	875 mV $\pm$ 3 mV
Reference – 20 dB	750 mV $\pm$ 4 mV
Reference – 30 dB	625 mV $\pm$ 4 mV
Reference – 40 dB	500 mV $\pm$ 5 mV
Reference – 50 dB	375 mV $\pm$ 6 mV
Reference – 60 dB	250 mV $\pm$ 7 mV
Reference – 70 dB	125 mV $\pm$ 8 mV

### Linear Output and Step Gain Adjustments

21. Press the following analyzer keys.

AMPLITUDE 50 (-dBm)  
 SCALE LOG LIN (LIN) More 1 of 2  
 AMPTD UNITS dBm

22. Set the synthesizer amplitude to the level recorded in step 8 and adjust A14R34 LIN for a DMM reading of 1000 mV  $\pm$ 1 mV.
23. Make the adjustments indicated in Table 2-6.

Table 2-6. Linear Gain Check

Adjust	Synthesizer Level	Reference Level (dBm)	DMM Reading
A14R34	Reference from step 8	-50	1000 mV $\pm$ 1 mV
A14R33	Reference – 10 dB	-60	1000 mV $\pm$ 5 mV
A14R30	Reference – 20 dB	-70	1000 mV $\pm$ 5 mV
A14R27	Reference – 30 dB	-80	1000 mV $\pm$ 5 mV
N/A	Reference – 40 dB	-90	1000 mV $\pm$ 30 mV

---

## 8. CAL FREQ Adjustment Routine

This adjustment applies to:

- All HP 8590 E-Series and L-Series spectrum analyzers
- HP 8591C cable TV analyzers
- HP 8594Q QAM analyzers

The **CAL FREQ** softkey accesses an internal self-adjustment routine. The “CAL FREQ Adjustment Routine” adjusts the analyzer to obtain frequency accuracy using CAL OUT signal. The following adjustments are automatically performed by **CAL FREQ** routine.

- Sweptime calibration
- YTO offset and slope
- FM coil timing constants
- Span attenuator
- FM detector sensitivity

### Equipment Required

- Cable, BNC, 20 cm (9 in)
- Adapter, Type N (m) to BNC (f)

### Additional Equipment for Option 026

- Adapter, Type APC-3.5 (f) to APC-3.5 (f)

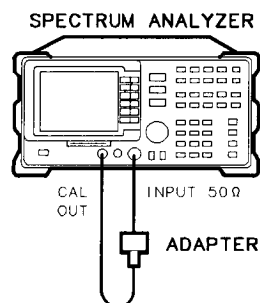
### Additional Equipment for 75 $\Omega$ Input

- Cable, BNC, 75  $\Omega$ , 30 cm (12 in)

---

**Caution** Use only 75  $\Omega$  cables, connectors, or adapters on instruments equipped with 75  $\Omega$  inputs or damage to the input connectors will occur.

---



sh28e

**Figure 2-13. CAL FREQ Adjustment Routine Setup**



### Procedure

Interrupting this routine may result in corrupt data being stored in RAM. If this occurs, rerun the CAL FREQ adjustment routine.

---

**Caution** Use only 75  $\Omega$  cables, connectors, or adapters on instruments equipped with 75  $\Omega$  inputs or damage to the input connectors will occur.

---

1. Connect the CAL OUT to the INPUT 50  $\Omega$  with the BNC cable. See Figure 2-13.  
*75  $\Omega$  input:* Connect the CAL OUT to the INPUT 75  $\Omega$  with the 75  $\Omega$  BNC cable.
2. Press the following analyzer keys.

**CAL** CAL FREQ

The CAL FREQ adjustment routine will take a few minutes to run.

The internal adjustment data will be stored in working RAM. To store this data in nonvolatile memory, press CAL STORE.

If the CAL AMPTD adjustment routine has not been done, the following error message will be displayed: "CAL: DATA NOT STORED" and "CAL AMP NEEDED". Proceed with the CAL AMPTD adjustment routine and then press CAL STORE when done.

---

## 9. CAL AMPTD Adjustment Routine

### This adjustment applies to:

All HP 8590 E-Series and L-Series spectrum analyzers  
HP 8591C cable TV analyzers  
HP 8594Q QAM analyzers

The CAL AMPTD softkey accesses an internal self-adjustment routine. The following adjustments are automatically performed by CAL AMPTD .

- The reference level is calibrated by adjusting the gain of the IF section.
- The 3 dB resolution bandwidths are adjusted.
- Bandwidth amplitude errors are determined. Errors are corrected with video offsets.
- Step-gain and input-attenuator errors are determined. Errors are corrected with video offsets.
- Log fidelity is checked in 1 dB steps. Errors are corrected with video offsets.
- Frequency accuracy is tested and adjusted by using frequency offsets.

### Equipment

Cable, BNC, 20 cm (9 in)  
Adapter, Type N (m) to BNC (f)

### Additional Equipment for Option 026

Adapter, Type APC-3.5 (f) to APC-3.5 (f)

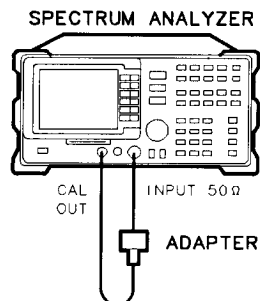
### Additional Equipment for 75 $\Omega$ Input

Cable, BNC, 75  $\Omega$ , 30 cm (12 in)

---

**Caution** Use only 75  $\Omega$  cables, connectors, or adapters on instruments equipped with 75  $\Omega$  inputs or damage to the input connectors will occur.

---



sh28e

**Figure 2-14. CAL AMPTD Adjustment Routine Setup**

## 9. CAL AMPTD Adjustment Routine

### Procedure

It is recommended to complete the “CAL FREQ Adjustment Routine” prior to performing the “CAL AMPTD Adjustment Routine.”

---

**Caution** Use only 75  $\Omega$  cables, connectors, or adapters on instruments equipped with 75  $\Omega$  inputs or damage to the input connectors will occur.

---

1. Connect the CAL OUT to the INPUT 50  $\Omega$  using a BNC cable. See Figure 2-14.  
*75  $\Omega$  input:* Connect the CAL OUT to the INPUT 75  $\Omega$  with the 75  $\Omega$  BNC cable.
2. Press the following analyzer keys.

**CAL** CAL AMPTD

The CAL AMPTD routine takes approximately 5 to 7 minutes to run. The internal adjustment data will be stored in working RAM. To store this data in nonvolatile memory, press CAL STORE .

---

## 10. CAL YTF Adjustment Routine

This adjustment applies to:

- HP 8592L spectrum analyzers
- HP 8593E spectrum analyzers
- HP 8595E spectrum analyzers
- HP 8596E spectrum analyzers

The **CAL YTF** softkey accesses an internal adjustment routine. This routine adjusts the slope and offset of the A3A8 YTF tune voltage for each harmonic mixing band. The “CAL FREQ Adjustment Routine” must be performed prior to this adjustment.

### Equipment Required

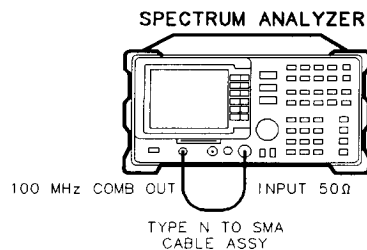
Cable, Type N (m) to SMA (m) (HP part number 8120-5148)

### Additional Equipment for Option 026

Cable, SMA (m) to (m)  
Adapter, Type APC-3.5 (f) to APC-3.5 (f)

### Additional Equipment for Model HP 8595E

Cable, BNC, 20 cm (9in)



sh29e

**Figure 2-15. CAL YTF Adjustment Setup**

### Procedure

1. Perform the CAL FREQ routine as indicated in the “CAL FREQ Adjustment Routine” in this chapter.
2. Connect the 100 MHz COMB OUT to INPUT 50 Ω using the YTF CAL cable. Refer to Figure 2-15.

*Model HP 8595E only:* Connect the CAL OUT to the INPUT 50 Ω using a BNC cable.

## 10. CAL YTF Adjustment Routine

3. Press the following keys.

**PRESET**

**CAL** CAL YTF

The CAL YTF routine will take a few minutes to run. The message "CAL: DONE" will be displayed when the routine has finished. The internal adjustment data will be stored in working RAM.

If the message "LOST COMB SIGNAL" is displayed, perform the Mixer Bias DAC Initialization procedure.

4. Press **CAL STORE** to store the YTF correction data in nonvolatile memory.

### Mixer Bias DAC Initialization

If the message "LOST COMB SIGNAL" is displayed, the current mixer bias DAC settings may not be adequate to ensure that a comb signal is displayed. Initialization of the mixer bias DAC may be required.

Perform this procedure only if the "LOST COMB SIGNAL" message is displayed while performing the CAL YTF routine and the analyzer firmware is version 3.1.90 or later.

1. Press the following keys to activate title mode.

**PRESET**

**CAL** More 1 of 4 More 2 of 4

**SERVICE DIAG**

**DISPLAY CAL DATA**

2. Record the displayed "Optimum Bias" DAC values for each frequency band.

**Table 2-7. Acceptable Mixer Bias DAC Correction Values**

Band	Optimum Bias	Acceptable Bias Range
1	_____	800 to 1900
2	_____	0 to 200
3	_____	1000 to 1800
4	_____	400 to 750

3. If the recorded "Optimum Bias" values are within the acceptable ranges indicated in Table 2-7, RF section troubleshooting is necessary.

If the recorded "Optimum Bias" values are not within the acceptable ranges indicated in Table 2-7, complete the rest of this procedure to initialize the mixer bias DAC values.

## 10. CAL YTF Adjustment Routine

4. Press the following keys to allow entry of the default mixer bias DAC values.

**PRESET**

**FREQUENCY** -2001 **Hz**

**DISPLAY**

**CHANGE TITLE**

5. Enter CALMXRDATA 1600,1; as a title entry to set the mixer bias value to 1600 for band 1.
6. Press the following keys to store the mixer bias value for band 1 in nonvolatile memory.

**CAL** More 1 of 4 More 2 of 4

**SERVICE CAL**

**EXECUTE TITLE**

7. Press the following keys to allow entry of the default mixer bias DAC value for band 2.

**DISPLAY**

**CHANGE TITLE**

**CLEAR**

8. Enter CALMXRDATA 20,2; as a title entry to set the mixer bias value to 20 for band 2.
9. Press the following keys to store the mixer bias value for band 2 in nonvolatile memory.

**CAL** More 1 of 4 More 2 of 4

**SERVICE CAL**

**EXECUTE TITLE**

10. Press the following keys to allow entry of the default mixer bias DAC value for band 3.

**DISPLAY**

**CHANGE TITLE**

**CLEAR**

11. Enter CALMXRDATA 1300,3; as a title entry to set the mixer bias value to 1300 for band 3.
12. Press the following keys to store the mixer bias value for band 3 in nonvolatile memory.

**CAL** More 1 of 4 More 2 of 4

**SERVICE CAL**

**EXECUTE TITLE**

13. Press the following keys to allow entry of the default mixer bias DAC value for band 4.

**DISPLAY**

**CHANGE TITLE**

**CLEAR**

## 10. CAL YTF Adjustment Routine

14. Enter CALMXRDATA 520,4; as a title entry to set the mixer bias value to 520 for band 4.
15. Press the following keys to store the mixer bias value for band 4 in nonvolatile memory.

**CAL** More 1 of 4 More 2 of 4

**SERVICE CAL**

**EXECUTE TITLE**

16. Press the following keys to check the default mixer bias DAC values.

**PRESET**

**CAL** More 1 of 4 More 2 of 4

**SERVICE DIAG**

**DISPLAY CAL DATA**

Confirm that the "Optimum Bias" DAC values displayed for band 1 through band 4 are 1600, 20, 1300, and 520.

17. Repeat the CAL YTF adjustment procedure.
18. Perform the CAL MXR adjustment procedure.

---

## 11. CAL MXR Adjustment Routine

**This adjustment applies to:**

- HP 8592L spectrum analyzers
- HP 8593E spectrum analyzers
- HP 8595E spectrum analyzers
- HP 8596E spectrum analyzers

The CAL MXR softkey accesses an internal adjustment routine which optimizes the dc bias for the A3A6 Dual Band Mixer when in high band (2.75 to 22 GHz). The CAL YTF routine must be performed prior to this adjustment. New frequency response correction constants must be developed following the CAL MXR Adjustment Routine.

### Equipment Required

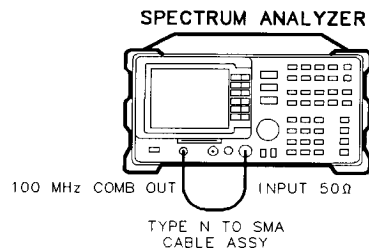
Cable, Type N (m) to SMA (m)

### Additional Equipment for Option 026

Cable, CAL Comb  
Adapter, Type APC-3.5 (f) to APC-3.5 (f)

### Additional Equipment for Model HP 8595E

Cable, BNC, 20 cm (9in)



sh29e

**Figure 2-16. CAL MXR Adjustment Setup**



### Procedure

1. Perform the CAL YTF routine as indicated in the “CAL YTF Adjustment Routine” in this chapter.
2. Connect the 100 MHz COMB OUT to INPUT 50  $\Omega$  using the CAL YTF cable (Type N to SMA cable). Refer to Figure 2-16.

*Model HP 8595E only:* Connect the CAL OUT to the INPUT 50  $\Omega$  using a BNC cable.

3. Press the following analyzer keys.

```
PRESET
FREQUENCY -2001 Hz
CAL More 1 of 4 More 2 of 4
SERVICE CAL CAL MXR
```

Note that the frequency of -2001 Hz is necessary to access the SERVICE CAL routines.

The CAL MXR routine will take a few minutes to run. The message “CAL: DONE” will be displayed when the routine has finished. The internal adjustment data will be stored in working RAM.

4. Press CAL STORE to store the correction data in nonvolatile memory.

---

## 12. Second Converter

### This adjustment applies to:

HP 8590L spectrum analyzers  
HP 8591E spectrum analyzers  
HP 8591C cable TV analyzers

The RF output of the tripler is adjusted by observing an analyzer connected to the 321.4 MHz second converter output, and adjusting the slug-tuned cavity for maximum signal.

The second IF bandpass filter is adjusted for a 2.1214 GHz bandpass using the Dishal method. The second mixer match is adjusted for maximum output.

The LO is swept through the range of the 2.1214 GHz bandpass while the output is observed with an analyzer and the characteristics are evaluated.

### Equipment Required

Microwave spectrum analyzer  
Tuning tool  
Cable, SMB (f) to BNC (m)  
Adapter, SMB (f) to SMB (f)  
Adapter, SMB (m) to SMB (m)  
Adapter, N (m) to BNC (f)

### Procedure

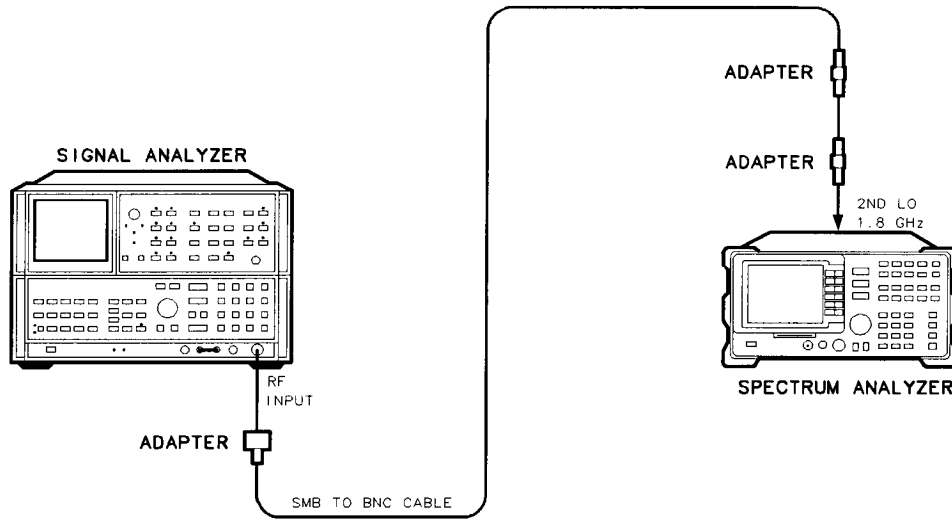
#### Tripler Adjustment

1. Turn the analyzer **LINE** switch to OFF. Remove the instrument cover assembly. Refer to the "Instrument Cover" removal procedure in Chapter 3.
2. Turn the analyzer **LINE** switch to ON.
3. Press INSTRUMENT PRESET on the microwave spectrum analyzer and set the controls as follows:

CENTER FREQUENCY .....	1.8 GHz
FREQUENCY SPAN .....	10 MHz
REFERENCE LEVEL .....	-20 dBm
dB/DIV .....	2 dB/DIV

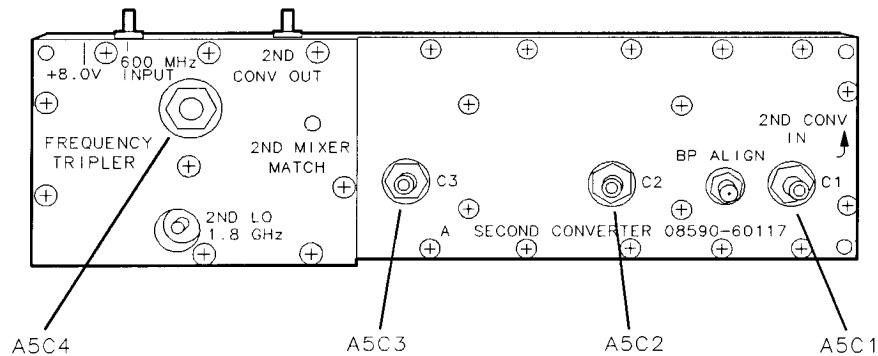
4. Connect the microwave spectrum analyzer to the 2ND LO 1.8 GHz port on the A5 Second Converter using SMB adapters and the test cable. See Figure 2-17.

## 12. Second Converter



sh226e

**Figure 2-17. Tripler Adjustment Setup**



sh227e

**Figure 2-18. Second Converter Adjustment Location**

5. Use the tuning tool to adjust A5C4 FREQUENCY TRIPLER (see Figure 2-18) for maximum signal amplitude as observed on the analyzer. Readjust the reference level of the microwave spectrum analyzer as necessary to keep the signal on screen. The 1.8 GHz signal should be  $-19$  dBm to  $-24$  dBm.

Note that when adjusting with the tuning tool, the signal amplitude will change as the lock nuts are tightened. Optimum signal amplitude should be maintained while tightening these lock nuts.

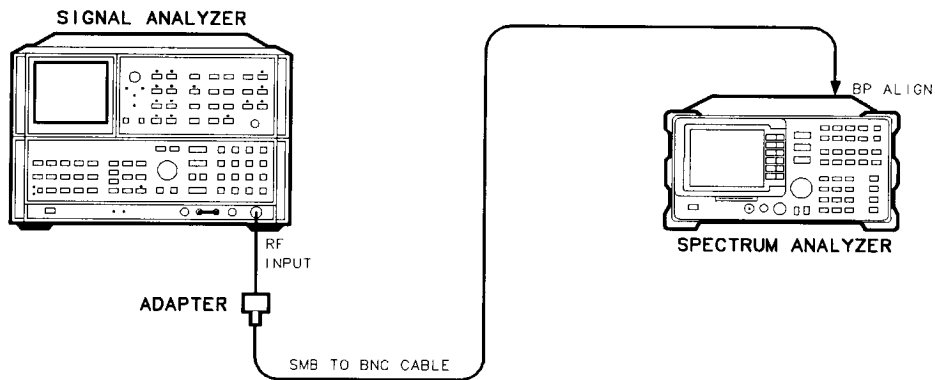
## 12. Second Converter

### Second Converter Bandpass

6. Set the microwave spectrum analyzer controls as follows:

CENTER FREQUENCY ..... 2.1214 GHz  
FREQUENCY SPAN ..... 5 MHz  
REFERENCE LEVEL ..... -30 dBm

7. Connect the microwave spectrum analyzer to the BP ALIGN port on the A5 Second Converter of the analyzer using the test cable. See Figure 2-19.



sh228e

**Figure 2-19. Second Converter Bandpass Adjustment Setup**

8. With nothing connected to the analyzer INPUT 50  $\Omega$  (*Option 001: INPUT 75  $\Omega$* ), press the following keys.

**PRESET**  
**PEAK SEARCH**  
**MKR FCTN** MK TRACK ON OFF (ON)  
**SPAN** 10 **MHz**

Wait for AUTO ZOOM message to disappear.

9. Set the analyzer as follows:

**MKR FCTN** MK TRACK ON OFF (OFF)  
**SPAN** 0 **Hz**

## 12. Second Converter

- Loosen the lock nut on A5C1, A5C2, and A5C3. Carefully turn tuning screws clockwise until they reach the bottom of the cavity. *Do not force the tuning screws down.*
- Turn A5C1 counterclockwise for a peaked signal on the HP 8566A/B. Lightly tighten the lock nut.
- Turn A5C2 counterclockwise for a minimum signal on the analyzer. Lightly tighten the lock nut.
- Turn A5C3 counterclockwise for peak signal on the analyzer. Lightly tighten the lock nut.
- Repeat steps 11 through 13 until no further improvement is noticeable. Tighten the lock nuts without changing the amplitude on the display.

## Second Mixer Match

- After removing W10, connect the microwave spectrum analyzer to the 2ND CONV OUT port (see Figure 2-18) using the test cable. See Figure 2-20.

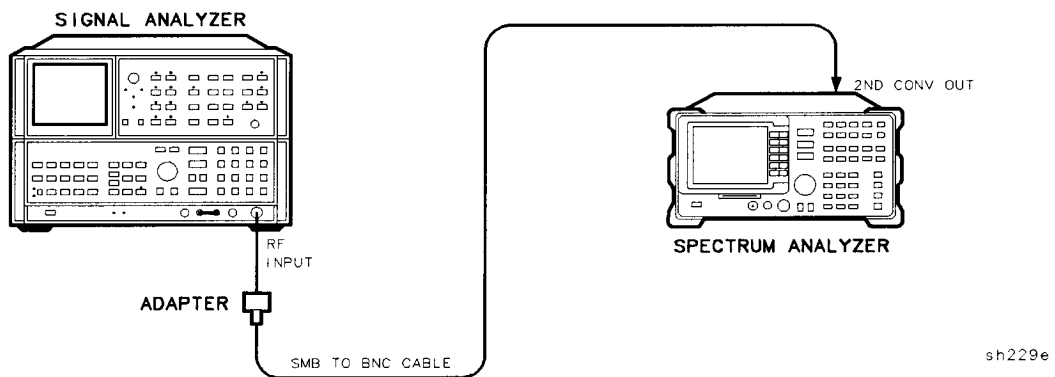


Figure 2-20. Second Mixer Match Adjustment Setup

- Set the microwave spectrum analyzer controls as follows:

CENTER FREQUENCY	.....	321.4 MHz
REFERENCE LEVEL	.....	-40 dBm
SPAN	.....	20 MHz
dB/DIV	.....	1 dB/DIV
- Adjust A5 2ND MIXER MATCH (refer to Figure 2-18) for maximum amplitude as displayed on the microwave spectrum analyzer. Adjust the reference level as necessary to keep the signal near top-screen.

## 12. Second Converter

### Swept Bandpass Check

18. Set the analyzer controls as follows:

SPAN 20 MHz  
SWEEP 20 SEC

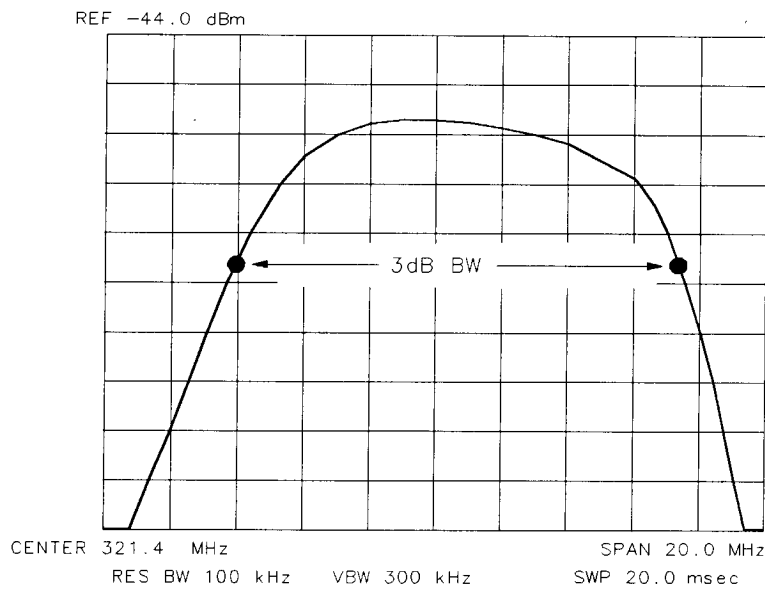
19. On the microwave spectrum analyzer, press trace B and MAX HOLD. Wait for at least one complete sweep. Then press the following keys to measure the 3 dB bandwidth.

TRACE B VIEW  
A ◀ ▶ B  
PEAK SEARCH  
MARKER MODE  $\Delta$

20. Rotate the knob counterclockwise so that the marker delta amplitude reads  $-3$  dB.

21. Press MARKER MODE  $\Delta$  and rotate the knob clockwise so that the marker delta amplitude reads 0 dB and is on the right-hand side of the response. Read the marker delta frequency; it should be  $15$  MHz  $\pm 2.5$  MHz. See Figure 2-21.

22. The maximum ripple should be less than 1 dB for a bandwidth of 6 MHz.



8566A/B DISPLAY

sh230e

**Figure 2-21. Second Converter Bandpass Ripple Measurement**

## 13. Third Converter and Second IF Bandpass

This adjustment applies to:

All HP 8590 E-Series and L-Series spectrum analyzers  
 HP 8591C cable TV analyzers  
 HP 8594Q QAM analyzers

The 321.4 MHz, second IF bandpass filter is adjusted for maximum signal amplitude.

The CAL OUT amplitude is measured and adjusted for  $-20 \text{ dBm} \pm 0.4 \text{ dB}$ . The insertion loss of a low-pass filter (LPF) and 10 dB attenuator are characterized. The harmonics of the CAL OUT signal are suppressed with the LPF before the amplitude accuracy is measured using a power meter.

### Equipment Required

Synthesized sweeper  
 Microwave spectrum analyzer  
 Measuring receiver (*used as a power meter*)  
 Power meter  
 Low power sensor with a 50 MHz reference attenuator  
 Power sensor, 300 MHz  
 Power splitter  
 Attenuator, 10 dB, Type N (m to f), dc-12.4 GHz  
 Low-pass filter, 300 MHz  
 IF test board  
 Cable, Type N, 152 cm (60 in)  
 Cable, BNC, 120 cm (48 in)  
 Test cable, SMB (f) to BNC (m) (*two required*)  
 Adapter, APC 3.5 (f) to Type N (f)  
 Adapter, Type N (f) to BNC (m) (*two required*)  
 Adapter, Type N (m) to BNC (f)

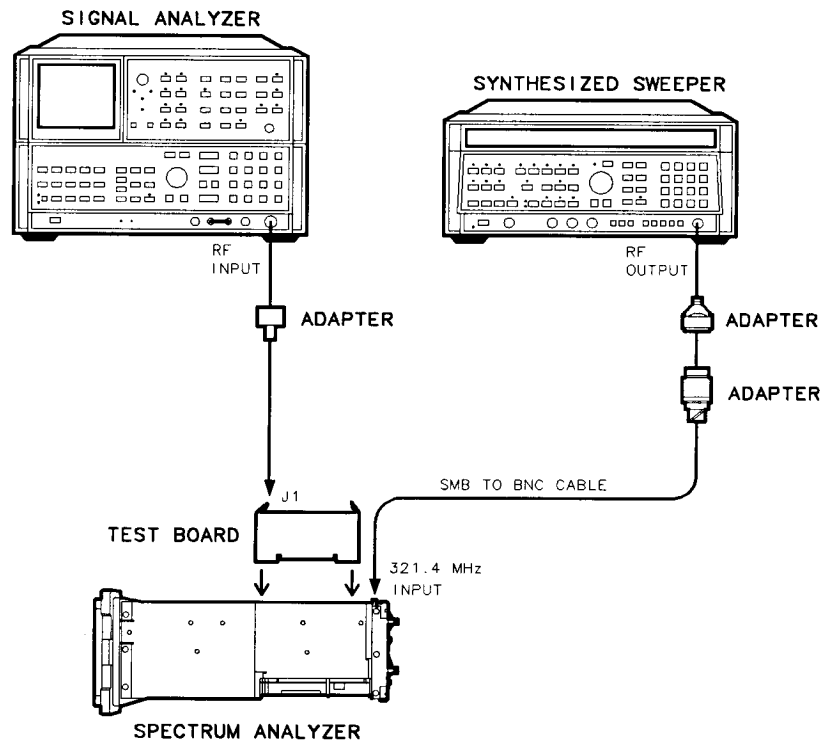
### Additional Equipment for Models HP 8590L Option 713

Microwave frequency counter

### Additional Equipment for 75 $\Omega$ Input

Adapter, minimum loss  
 Adapter, 75  $\Omega$  to 50  $\Omega$   
 Adapter, Type N (f) 75  $\Omega$  to BNC (m) 75  $\Omega$   
 Cable, BNC, 75  $\Omega$ , 30 cm (12 in)

### 13. Third Converter and Second IF Bandpass



sh210e

Figure 2-22. Second IF Bandpass Filter Adjustment Setup

#### Procedure

#### Second IF Bandpass Filter

1. Press INSTRUMENT PRESET on the microwave spectrum analyzer, then set the controls as follows:

CENTER FREQUENCY .....	21.4 MHz
FREQUENCY SPAN .....	50 MHz
REFERENCE LEVEL .....	-30 dBm
dB/DIV .....	1 dB/DIV

2. Set the synthesized sweeper controls as follows:

CW .....	321.4 MHz
POWER LEVEL .....	-26 dBm

3. Turn the analyzer **LINE** switch to OFF. Remove the instrument cover assembly.
4. Remove the first IF bandwidth filter assembly, A11.
5. Install the IF test board into the A11 slot.
6. Remove the W9 cable from A9J4, 321.4 MHz IF INPUT.
7. Connect the synthesized sweeper output to A9J4. Refer to Figure 2-22.
8. Press the analyzer **LINE** switch to ON.
9. Press the following analyzer keys.

**PRESET**  
**SPAN** 0 **Hz**



### 13. Third Converter and Second IF Bandpass

10. Connect the microwave spectrum analyzer RF INPUT to J1 of the IF test board. Refer to Figure 2-22.
11. Adjust A9C44, A9C46, and A9C47 for maximum signal amplitude as observed on the microwave spectrum analyzer. Adjust the reference level of the microwave spectrum analyzer, as necessary, to display the signal below the top graticule.
12. Remove the test board from the A11 slot and install the A11 bandwidth filter assembly.
13. Reconnect W9 to A9J4, 321.4 MHz INPUT.

If you are adjusting an HP 8590L Option 713, continue with the "600 MHz Adjustment."

If you are adjusting an HP 8591C HP 8591E, HP 8593E, HP 8594E, HP 8594Q, HP 8595E, or HP 8596E, continue with the "LPF, Attenuator and Adapter Insertion Loss Characterization."

#### 600 MHz Adjustment

Do this adjustment only if you are testing an HP 8590L Option 713. Otherwise, continue with the "LPF, Attenuator and Adapter Insertion Loss Characterization" section.

14. Set the microwave frequency counter controls as follows:

50 $\Omega$ /1 M $\Omega$ .....	50 $\Omega$ Impedance
10 Hz–500 MHz/500 MHz–18 GHz .....	10 Hz–500 MHz
SAMPLE RATE .....	Midrange

15. Disconnect W8 from A9J5 600 MHz OUT, then connect the microwave frequency counter to A9J5.
16. Adjust A9R68, 600 MHz ADJ, for a frequency of 600 MHz $\pm$ 2 kHz (599.998000 MHz to 600.002000 MHz).
17. Remove the test cable from A9J5, then reconnect W8.
18. Continue with "LPF, Attenuator and Adapter Insertion Loss Characterization."

#### LPF, Attenuator and Adapter Insertion Loss Characterization

19. Zero and calibrate the measuring receiver and power sensor combination in LOG mode as described in the measuring receiver operation manual.

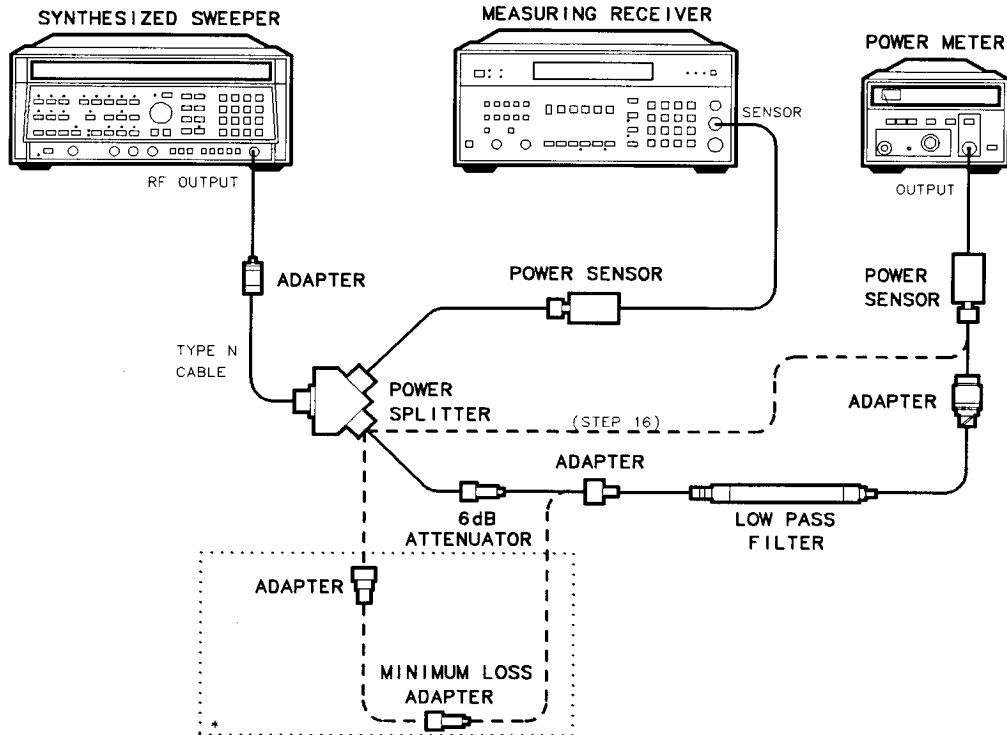
---

**Caution** Do not attempt to calibrate the power sensor without the reference attenuator or damage to the power sensor will occur.

---

20. Zero and calibrate the power meter and 300 MHz power sensor, as described in the power meter operation manual.
21. Connect the equipment as shown in Figure 2-23. Connect the 300 MHz power sensor directly to the Power Splitter (bypass the LPF, Attenuator and Adapters).

### 13. Third Converter and Second IF Bandpass



sh211e

**Figure 2-23. LPF Characterization**

22. Press INSTRUMENT PRESET on the synthesized sweeper. Set the controls as follows:
  - CW ..... 300 MHz
  - POWER LEVEL ..... -15 dBm
23. Allow the power sensors to settle, then on the measuring receiver, press RATIO mode. Power indication should be 0 dB.
24. On the power meter, press the dB REF mode key. Power indication should be 0 dB.
25. Connect the LPF, Attenuator and adapters as shown in Figure 2-23.
26. Record the measuring receiver reading in dB. This is the relative error due to mismatch.
 

**Mismatch Error \_\_\_\_\_ dB**
27. Record the power meter reading in dB. This is the relative uncorrected insertion loss of the LPF, attenuator, and adapters.
 

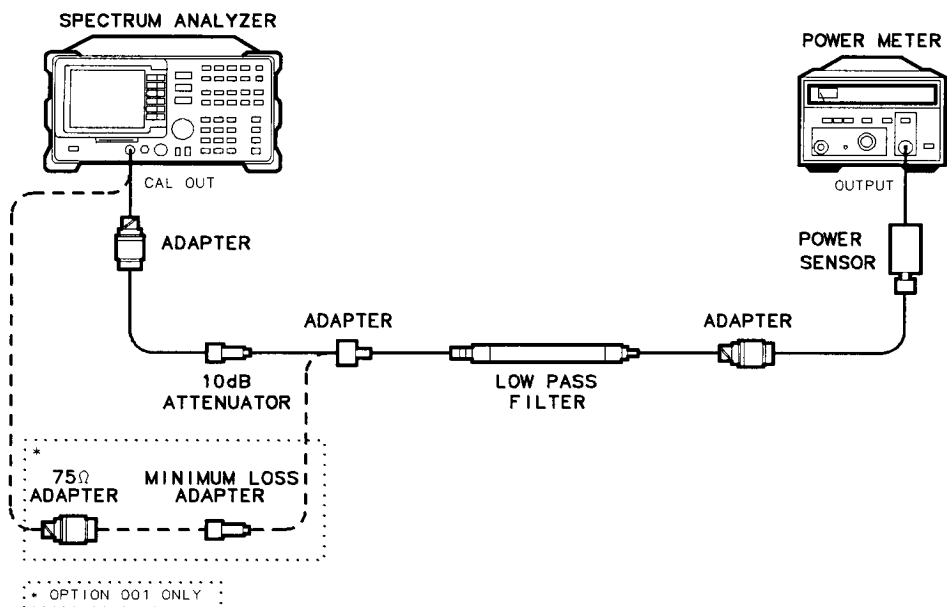
**Uncorrected Insertion Loss \_\_\_\_\_ dB**
28. Subtract the Mismatch Error (step 21) from the Uncorrected Insertion Loss (step 22). This is the corrected insertion loss.
 

**Corrected Insertion Loss \_\_\_\_\_ dB**

For example, if the Mismatch Error is +0.3 dB and the uncorrected Insertion Loss is -10.2 dB, subtracting the mismatch error to the insertion loss gives a corrected reading of -10.5 dB.

### 300 MHz Calibrator Amplitude Adjustment

29. Connect the equipment as shown in Figure 2-24. The analyzer should be positioned so that the setup of the adapters, LPF and attenuator do not bind. It may be necessary to support the center of gravity of the devices.



sh212e

Figure 2-24. 300 MHz Calibrator Amplitude Accuracy Test Setup

30. On the power meter, press the dBm mode key. Record the power meter reading in dBm.

**Power Meter Reading \_\_\_\_\_ dBm**

31. Subtract the Corrected Insertion Loss (step 23) from the power meter reading (step 25) and record as the CAL OUT power. The CAL OUT should be  $-20 \text{ dBm} \pm 0.4 \text{ dB}$ .

$$\text{CAL OUT Power} = \text{Power Meter Reading} - \text{Corrected Insertion Loss}$$

For example, if the Corrected Insertion Loss is  $-10.0 \text{ dBm}$ , and the measuring receiver reading is  $-30 \text{ dBm}$ , then  $-30 \text{ dBm} - (-10.0) \text{ dBm} = -20 \text{ dBm}$ .

**CAL OUT Power \_\_\_\_\_ dBm**

32. Adjust A9R19 CAL OUT ADJ accordingly if the CAL OUT amplitude is not  $-20 \text{ dBm} \pm 0.4 \text{ dB}$  as calculated in step 26.

---

## 14. Comb Generator

### This adjustment applies to:

- HP 8592L spectrum analyzers
- HP 8593E spectrum analyzers
- HP 8596E spectrum analyzers

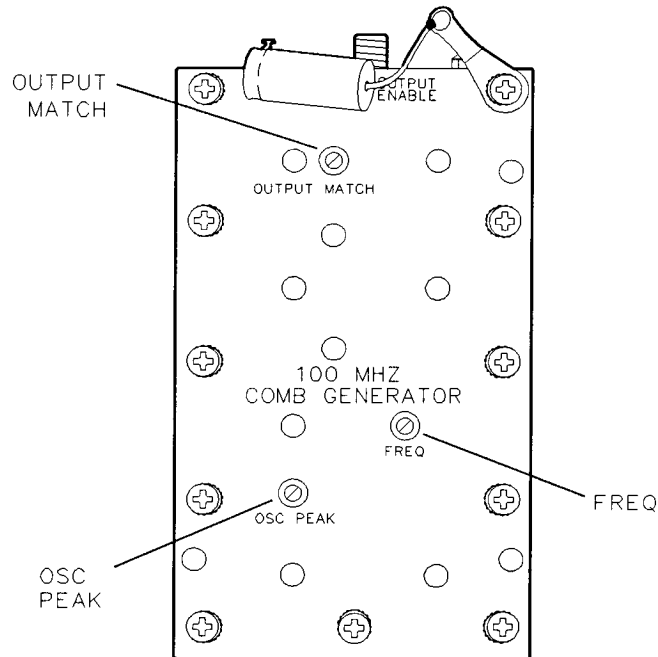
The output signal from the A3A1 comb generator assembly, with the Step Recovery Diode Module (SRD) disconnected, is adjusted for maximum peak-to-peak voltage. A3A1C5 FREQ is centered, and the comb generator frequency is measured with a frequency counter. If the measured frequency is not  $100.000 \text{ MHz} \pm 0.0004 \text{ MHz}$ , A3A1L3 is selected to bring the frequency within tolerance.

The comb generator signal is adjusted for maximum output power as measured with a measuring receiver (used as a power meter). If the amplitude is not  $+26.0 \pm 0.8 \text{ dBm}$ , A3A1R6 is selected to bring the amplitude within tolerance.

A3A1C5 FREQ is adjusted for a comb generator frequency of  $100.000000 \text{ MHz} \pm 0.000010 \text{ MHz}$  (tolerance of  $\pm 10 \text{ Hz}$ ).

### Equipment Required

- Oscilloscope
- Frequency counter
- Measuring receiver (*used as a power meter*)
- Power sensor, 300 MHz
- Attenuator, 20 dB
- Cable, SMA, 90 cm (36 in.)
- Cable, BMC, 120 cm (48 in.)
- Adapter, Type N (m) to SMA (f)
- Adapter, Type N (f) to Type N (f)
- Adapter, Type N (m) to BNC (f)



sh213e

**Figure 2-25. Comb Generator Adjustment Location**

### Procedure

1. Turn the analyzer **(LINE)** switch to OFF. Remove the instrument cover assembly.
2. Remove the front-end assembly. Refer to the “Front-End Assembly” removal procedure.
3. Remove the A3A1 comb generator assembly from the front-end assembly and place in a service position, leaving W13 connected to the A7 Analog Interface.
4. Remove W24 from the A3A1J1 comb generator output connector. Connect the SMA cable to A3A1J1. Refer to Figure 2-25.
5. Turn the analyzer **(LINE)** switch to ON.
6. Press the following analyzer keys.

**(AUX CTRL) COMB GEN ON OFF (ON)**

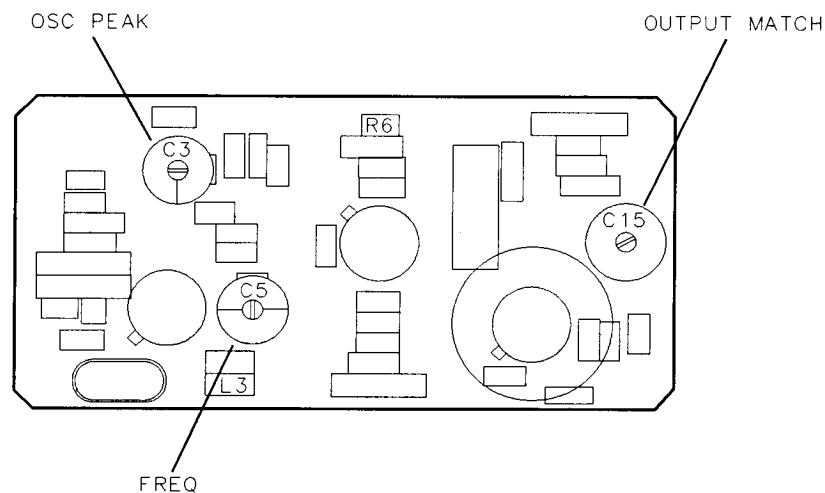
### Frequency

7. Connect the other end of the SMA cable to the 20 dB attenuator. Connect the output of the 20 dB attenuator to the 10 Hz to 500 MHz input of the frequency counter using adapters and the BNC cable.
8. Adjust A3A1C5 FREQ for 100.000000 MHz  $\pm$ 0.00004 MHz. Refer to Figure 2-25 for adjustment location.
9. Disconnect the BNC cable from the frequency counter and 20 dB attenuator, then connect the BNC cable to CH1 of the oscilloscope. Set the oscilloscope by activating AUTOSCALE, located under the setup key.
10. Adjust both A3A1C15 OUTPUT MATCH and A3A1C3 OSC PEAK for maximum peak-to-peak voltage on the oscilloscope display.

## 14. Comb Generator

11. Reconnect the BNC cable through the 20 dB attenuator to the frequency counter input. The comb generator frequency must be  $100.000000 \text{ MHz} \pm 0.00004 \text{ MHz}$ .
12. Repeat steps 8 through 11 until the frequency is within specification.
13. Perform the following steps only if the comb generator frequency cannot be brought within tolerance with the output power peaked.
  - Set the **LINE** switch to OFF and remove the power cord. Remove the A3A1 comb generator cover plate.
  - Change the selected value of A3A1L3 to obtain an output frequency of  $100.000500 \text{ MHz} \pm 0.004 \text{ MHz}$  with A3A1C5 FREQ centered.

Increasing the value of A3A1L3 increases the output frequency of the comb generator. The frequency of the oscillator decreases about 500 Hz when the cover plate is installed. Refer to Figure 2-26 for component location.



sh214e

**Figure 2-26. Comb Generator Component Location**

- Each time the value of A3A1L3 is changed, reconnect the power cord, set the **LINE** switch to ON, and adjust A3A1C3 OSC PEAK for maximum signal. The output frequency changes when A3A1C3 OSC PEAK is adjusted. Reinstall the comb generator cover plate and repeat steps 8 through 12.

### Output Power

14. Zero and calibrate the power sensor/measuring receiver combination in log mode (power reads out in dBm). Enter the power sensor 0.1 GHz cal factor into the measuring receiver.
15. Connect the power sensor to the output of the 20 dB attenuator using an adapter.
16. Adjust A3A1C15 OUTPUT MATCH for maximum power output. The measuring receiver should measure +6 dBm  $\pm$ 0.8 dB.
17. If the output power of the comb generator is out of tolerance, perform the following:
  - Set the **LINE** switch to OFF, remove the power cord, and remove the A3A1 comb generator cover plate.
  - Change the selected value of A3A1R6 to obtain an output power reading of +6.0 dBm  $\pm$ 0.8 dB. Increasing the value of A3A1R6 decreases the output power of the comb generator, while decreasing the value increases the output power. Refer to Figure 2-26 for component location.
  - Each time the value of A3A1R6 is changed, reconnect the power cord, set the **LINE** switch to ON, and adjust A3A1C16 OUTPUT MATCH for maximum power out.
18. Reinstall the comb generator assembly cover plate and all the screws. Connect a BNC cable from the 20 dB attenuator to the frequency counter input using adapters.
19. Adjust A3A1C5 FREQ for a frequency counter reading of 100.000000 MHz  $\pm$ 0.000010 MHz (tolerance of  $\pm$ 10 Hz).
20. Set the **LINE** switch to OFF and reconnect W24 to A3A1J1.
21. Reinstall A3A1 comb generator assembly into RF Section. Refer to the A3A1 comb generator assembly replacement procedure.
22. Reinstall the front-end assembly in the analyzer. Refer to the “Front-End Assembly” replacement procedure.

---

## 15. Frequency Response of the HP 8590L, HP 8591C, and HP 8591E

### This adjustment applies to:

- HP 8590L spectrum analyzers
- HP 8591E spectrum analyzers
- HP 8591C cable TV analyzers

The frequency response (flatness) of the analyzer is measured with the corrections off. The source is adjusted to place the displayed signal at the analyzer center horizontal graticule line.

The flatness data is then entered into the analyzer using the **SERVICE CAL** functions. The error corrections are stored in battery backed RAM on the A16 processor/video assembly.

For analyzers equipped with 75  $\Omega$  inputs, the 50  $\Omega$  system is characterized before starting the "Frequency Response" adjustment procedure.

### Equipment Required

- Synthesized sweeper
- Measuring receiver (*used as a power meter*)
- Frequency synthesizer
- Power sensor, 1 MHz to 1.8 GHz
- Power splitter
- Adapter, Type N (f) to APC 3.5 (m)
- Adapter, Type N (m) to Type N (m)
- Cable, BNC, 122 cm (48 in.)
- Cable, Type N, 183 cm (72 in.)

### Additional Equipment for 75 $\Omega$ Inputs

- Power meter
- Power sensor, 75  $\Omega$
- Cable, BNC, 120 cm (48 in) 75  $\Omega$
- Adapter, Type N (f) 75  $\Omega$  to Type N (m) 50  $\Omega$
- Adapter, Type N (m) to BNC (m), 75  $\Omega$

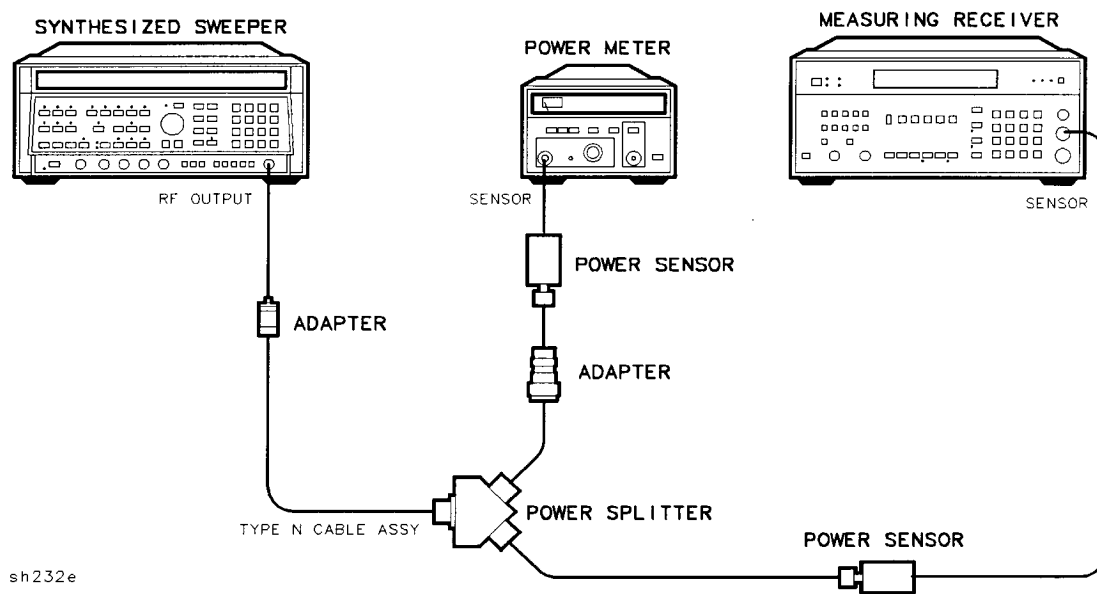
---

**Caution** Use only 75  $\Omega$  cables, connectors, or adapters on instruments equipped with 75  $\Omega$  inputs or damage to the input connectors will occur.

---



## 15. Frequency Response of the HP 8590L, HP 8591C, and HP 8591E



**Figure 2-27. System Characterization Test Setup for 75  $\Omega$  inputs**

### Procedure for System Characterization (75 $\Omega$ input)

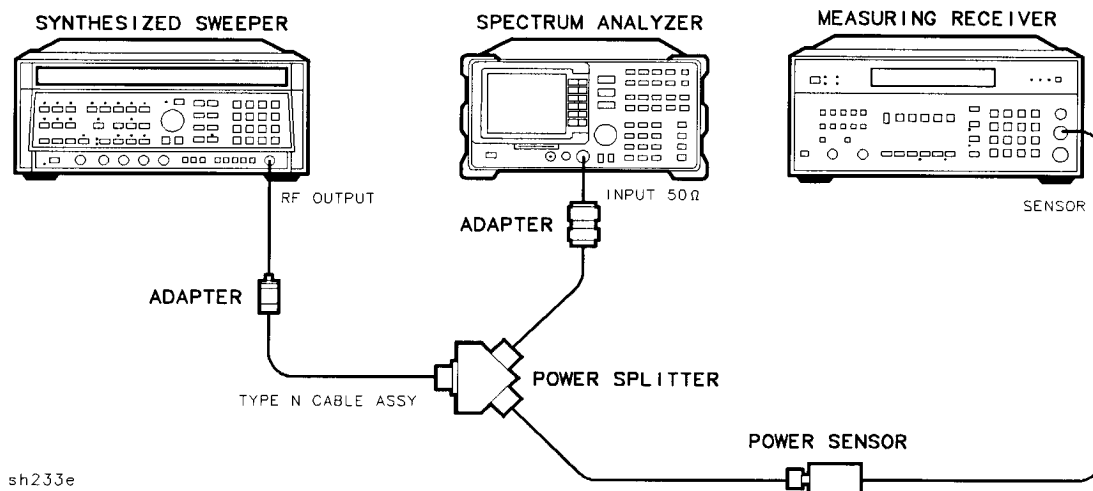
1. Zero and calibrate the measuring receiver and 1 MHz to 1.8 GHz power sensor as described in the measuring receiver operation manual.
2. Zero and calibrate the power meter and the 75  $\Omega$  power sensor as described in the power meter operation manual.
3. Press INSTRUMENT PRESET on the synthesized sweeper. Set the synthesized sweeper controls as follows:

CW .....	41 MHz
FREQ STEP .....	37 MHz
POWER LEVEL .....	5 dBm

4. Connect the equipment as shown in Figure 2-27.
5. Adjust the synthesized sweeper POWER LEVEL for a 0 dBm reading on the measuring receiver.
6. Record the power meter reading in Column 4 of Table 2-8, taking into account the cal factors of both power sensors.
7. On the synthesized sweeper, press CW and STEP UP, to step through the remaining frequencies listed in Table 2-8.

At each new frequency repeat steps 5 and 6, and enter each power sensor cal factor into the respective power meter.

## 15. Frequency Response of the HP 8590L, HP 8591C, and HP 8591E



**Figure 2-28. Frequency Response Setup**

### Procedure

1. Zero and calibrate the measuring receiver and 1 MHz to 1.8 GHz power sensor in log mode as described in the measuring receiver operation manual.
2. Connect the equipment as shown in Figure 2-28.
3. Press INSTRUMENT PRESET on the synthesized sweeper. Set the synthesized sweeper controls as follows:

CW ..... 300 MHz  
 FREQ STEP ..... 37 MHz  
 POWER LEVEL ..... -9 dBm

4. On the analyzer, press the following keys.

**PRESET**  
**CAL** More 1 of 4  
 CORRECT ON OFF (OFF)  
**FREQUENCY** 300 **MHz**  
 CF STEP AUTO MAN 37 **MHz**  
**SPAN** 12 **MHz**

75  $\Omega$  input: press **AMPLITUDE** More 1 of 2 AMPTD UNITS dBm

**AMPLITUDE** 10 **-dBm**  
 SCALE LOG LIN (LOG) 1 **dB**  
**BW** 1 **MHz**  
**PEAK SEARCH**  
**MKR FCTN** MK TRACK ON OFF (ON)

5. Adjust the synthesized sweeper POWER LEVEL for a MKR-TRK amplitude reading of -14 dBm  $\pm$ 0.1 dB.
6. Press RATIO mode on the measuring receiver.
7. Press the following analyzer keys.

**FREQUENCY** 41 **MHz**

## 15. Frequency Response of the HP 8590L, HP 8591C, and HP 8591E

- Set the synthesized sweeper CW to 41 MHz.
- Adjust the synthesized sweeper POWER LEVEL for an analyzer MKR-TRK amplitude reading of  $-14 \text{ dBm} \pm 0.1 \text{ dB}$ .
- Record the power ratio here and in Column 2 of Table 2-8 for 41 MHz.

**Measuring Receiver Reading at 41 MHz \_\_\_\_\_ dB**

- Press the following analyzer keys.

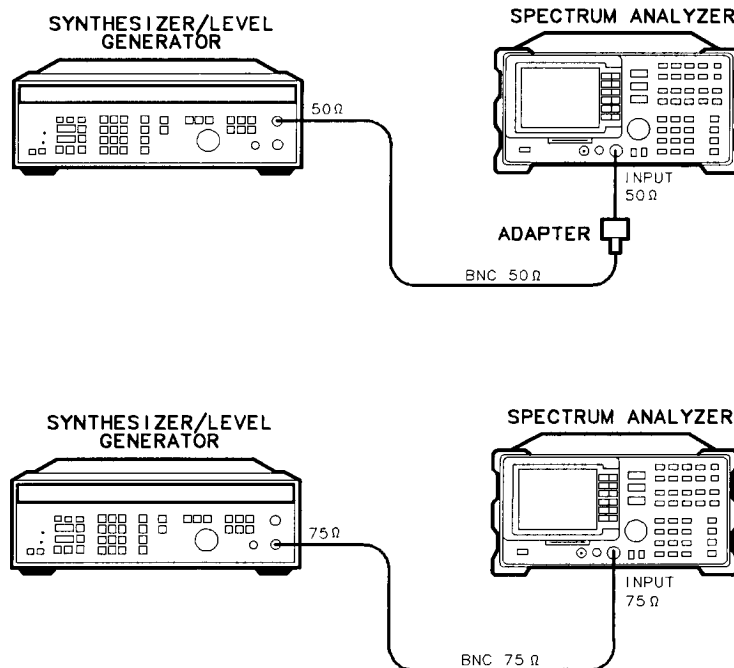
**FREQUENCY** 78 **MHz**

- Set the synthesized sweeper CW to 78 MHz.
- Adjust the synthesized sweeper POWER LEVEL for an analyzer MKR-TRK amplitude reading of  $-14 \text{ dBm} \pm 0.1 \text{ dB}$ .
- Record the power ratio displayed on the measuring receiver in Column 2 of Table 2-8 for 78 MHz.
- On the analyzer, press **FREQUENCY** and **↑** (step up), to step through the remaining frequencies listed in Column 1 of Table 2-8. At each new frequency repeat steps 13 through 15, entering the power sensor Cal Factor into the measuring receiver as indicated in Column 3 of Table 2-8.
- On the synthesized sweeper, press CW and STEP UP.

---

**Caution** Use only  $75 \Omega$  cables, connectors, or adapters on instruments equipped with  $75 \Omega$  inputs or damage to the input connectors will occur.

---



sh234e

**Figure 2-29. Frequency Response for 4 MHz Setup**

## 15. Frequency Response of the HP 8590L, HP 8591C, and HP 8591E

### Frequency Response Error At 4 MHz

17. Using a cable, connect the frequency synthesizer directly to the INPUT 50 $\Omega$ . See Figure 2-29. For 75  $\Omega$  inputs use a 75  $\Omega$  cable to connect the frequency synthesizer 75 $\Omega$  OUTPUT to the INPUT 75 $\Omega$  of the analyzer. Set the frequency synthesizer 50–75  $\Omega$  switch to the 75  $\Omega$  position. See Figure 2-29.

Set the frequency synthesizer controls as follows:

FREQUENCY ..... 41 MHz  
AMPLITUDE ..... -15 dBm  
AMPTD INCR ..... 0.05 dB

18. Press the following analyzer keys.

**MKR** **MARKER 1 ON OFF (OFF)**  
**SPAN** **12 (MHz)**  
**FREQUENCY** **41 (MHz)**  
**PEAK SEARCH**  
**MKR FCTN** **MK TRACK ON OFF (ON)**  
**BW** **10 (kHz)**  
**SPAN** **100 (kHz)**

Wait for AUTO ZOOM message to disappear.

19. Adjust the frequency synthesizer AMPLITUDE until the MKR-TRK reads -14 dBm. This corresponds to the amplitude at 41 MHz recorded in step 10. Record the frequency synthesizer amplitude here.

**Frequency Synthesizer AMPLITUDE setting (41 MHz) \_\_\_\_\_ dBm**

20. Set the frequency synthesizer FREQUENCY to 4 MHz.

21. AUTO ZOOM on the 4 MHz signal by pressing the following analyzer keys.

**FREQUENCY** **4 (MHz)**  
**MKR** **MKR FCTN** **MK TRACK ON OFF (OFF)**  
**FREQUENCY** **4 (MHz)**  
**SPAN** **12 (MHz)**  
**PEAK SEARCH** **NEXT PK RIGHT**  
**MKR FCTN** **MK TRACK ON OFF (ON)**  
**SPAN** **100 (kHz)**

Wait for AUTO ZOOM message to disappear.

22. Adjust the frequency synthesizer AMPLITUDE for a MKR amplitude reading of -14.00 dBm  $\pm$ .05 dB. Record the frequency synthesizer AMPLITUDE setting here.

**Frequency Synthesizer AMPLITUDE setting (4 MHz) \_\_\_\_\_ dBm**

23. Subtract the frequency synthesizer AMPLITUDE setting (4 MHz) recorded in step 22 from the frequency synthesizer AMPLITUDE setting (41 MHz) recorded in step 19. Record the result as the Amplitude Relative to 41 MHz here.

**4 MHz Amplitude Relative to 41 MHz \_\_\_\_\_ dB**

## 15. Frequency Response of the HP 8590L, HP 8591C, and HP 8591E

24. Add the result from step 23 to the reading from step 10 and enter that result in Column 2 of Table 2-8 (*Option 001 only*: Column 5) as the 4 MHz error (relative to 300 MHz).

*For 75  $\Omega$  input:*

Starting with the error at 41 MHz, add Column 3 (System Error) to Column 2 (Error Relative to 300 MHz) and record the result in Column 5 (Corrected Error Relative to 300 MHz).

### Entering Flatness Correction Data

25. Enter the pass code by pressing the following analyzer keys.

PRESET  
FREQUENCY -2001 Hz

75  $\Omega$  *input*: AMPLITUDE More 1 of 2 AMPTD UNITS dBm

26. To access the flatness correction menu, press the following analyzer keys.

CAL More 1 of 4 More 2 of 4  
SERVICE CAL  
FLATNESS DATA

Perform the next step *only if* all the flatness correction data must be replaced in memory due to the repair or replacement of the A16 processor/video assembly.

27. To initialize the area of memory where the flatness correction data is stored, press the following keys.

INIT FLT  
PRESET  
FREQUENCY -2001 Hz

75  $\Omega$  *input*: AMPLITUDE More 1 of 2 AMPTD UNITS dBm

CAL More 1 of 4 More 2 of 4  
SERVICE CAL  
FLATNESS DATA

28. To enter flatness corrections, press EDIT FLATNESS .
29. The frequency of the first data point, 4.00 MHz, will be displayed in the active function block of the analyzer display.
30. Use the data keys on the analyzer to enter the amplitude value for 4 MHz from Column 2 of Table 2-8 (75  $\Omega$  *input*: Column 5), Frequency Response Errors. Terminate the entry with the dB key. When entering negative amplitude values, precede the numeric entry with the - and dB keys or the -dB key.
- The BK SP (backspace) key may be used to correct any entry if the terminator, dB or -dB key has *not* been pressed. Re-enter the data if the terminator has been pressed.
31. Press  $\uparrow$  (step up) and enter the data from Table 2-8, Column 2 (75  $\Omega$  *input*: Column 5) for the next data point as described in step 29.

## 15. Frequency Response of the HP 8590L, HP 8591C, and HP 8591E

32. Repeat step 30 for the remaining flatness correction data points listed in Table 2-8.

At each point, verify that the frequency listed in the active function block corresponds to the frequency at which the data was taken. If these two frequencies do not correspond, press  $\uparrow$  (step up) or  $\downarrow$  (step down) until the proper frequency is displayed in the active function block.

If some data is incorrect after entering all of the data from Table 2-8, select the incorrect data point using  $\uparrow$  (step up) or  $\downarrow$  (step down) and re-enter the proper data.

33. After all corrections have been input, press the **STORE FLATNESS** softkey to store the correction data in nonvolatile memory. The instrument will automatically preset and display **CAL : DONE** in the active function block of the analyzer.

15. Frequency Response of the HP 8590L, HP 8591C, and HP 8591E

Table 2-8. Frequency Response Errors

Column 1 Frequency (MHz)	Column 2 Error Relative to 300 MHz (dB)	Column 3 Sensor CAL FACTOR (GHz)	Column 4 (75 $\Omega$ inputs) System Error (dB)	Column 5 (75 $\Omega$ inputs) Corrected Error Relative to 300 MHz (dB)
4	_____	N/A	N/A	_____
41	_____	0.03	_____	_____
78	_____	0.1	_____	_____
115	_____	0.1	_____	_____
152	_____	0.1	_____	_____
189	_____	0.3	_____	_____
226	_____	0.3	_____	_____
263	_____	0.3	_____	_____
300	_____	0.3	_____	_____
337	_____	0.3	_____	_____
374	_____	0.3	_____	_____
411	_____	0.3	_____	_____
448	_____	0.3	_____	_____
485	_____	0.3	_____	_____
522	_____	0.3	_____	_____
559	_____	1.0	_____	_____
596	_____	1.0	_____	_____
633	_____	1.0	_____	_____
670	_____	1.0	_____	_____
707	_____	1.0	_____	_____
744	_____	1.0	_____	_____
781	_____	1.0	_____	_____
818	_____	1.0	_____	_____
855	_____	1.0	_____	_____
892	_____	1.0	_____	_____

15. Frequency Response of the HP 8590L, HP 8591C, and HP 8591E

Table 2-8. Frequency Response Errors (continued)

Column 1 Frequency (MHz)	Column 2 Error Relative to 300 MHz (dB)	Column 3 Sensor CAL FACTOR (GHz)	Column 4 (75 $\Omega$ inputs) System Error (dB)	Column 5 (75 $\Omega$ inputs) Corrected Error Relative to 300 MHz (dB)
929	_____	1.0	_____	_____
966	_____	1.0	_____	_____
1003	_____	1.0	_____	_____
1040	_____	1.0	_____	_____
1077	_____	1.0	_____	_____
1114	_____	1.0	_____	_____
1151	_____	1.0	_____	_____
1188	_____	1.0	_____	_____
1225	_____	1.0	_____	_____
1262	_____	1.0	_____	_____
1299	_____	1.0	_____	_____
1336	_____	1.0	_____	_____
1373	_____	1.0	_____	_____
1410	_____	1.0	_____	_____
1447	_____	1.0	_____	_____
1484	_____	1.0	_____	_____
1521	_____	1.0	_____	_____
1558	_____	2.0	_____	_____
1595	_____	2.0	_____	_____
1632	_____	2.0	_____	_____
1669	_____	2.0	_____	_____
1706	_____	2.0	_____	_____
1743	_____	2.0	_____	_____
1780	_____	2.0	_____	_____
1817	_____	2.0	_____	_____



## 16. Frequency Response of the HP 8592L/94L, HP 8593E/94E/95E/96E, and HP 8594Q

This adjustment applies to:

- HP 8592L spectrum analyzers
- HP 8593E spectrum analyzers
- HP 8594E spectrum analyzers
- HP 8594L spectrum analyzers
- HP 8594Q QAM analyzer
- HP 8595E spectrum analyzers
- HP 8596E spectrum analyzers

Use the following table to determine which bands are measured and adjusted for your analyzer.

**Table 2-9. Analyzer Bands Measured and Adjusted**

Analyzer Model	Frequency Range	Bands
HP 8592L	22.0 GHz	0 through 4
HP 8592L (Option 026)	26.5 GHz	0 through 4
(Option 027)	26.5 GHz	0 through 4
HP 8593E	22.0 GHz	0 through 4
HP 8593E (Option 026)	26.5 GHz	0 through 4
(Option 027)	26.5 GHz	0 through 4
HP 8594E	2.9 GHz	0 only
HP 8594L	2.9 GHz	0 only
HP 8594Q	2.9 GHz	0 only
HP 8595E	6.5 GHz	0 and 1
HP 8596E	12.8 GHz	0 through 2

The frequency response (flatness) of the analyzer is measured with corrections off. The source amplitude is adjusted for a marker amplitude reading which is dependent upon the harmonic number of the band being measured. This is necessary since the source and power meter combination does not have sufficient dynamic range to measure the uncorrected frequency response.

The difference between the “target” marker amplitudes is taken into account when calculating the uncorrected flatness. The flatness data is then entered into the analyzer using the **SERVICE CAL** functions. The error corrections are stored in battery backed RAM on the A16 processor/video assembly.

## 16. Frequency Response of the HP 8592L/94L, HP 8593E/94E/95E/96E, and HP 8594Q

### Equipment Required

Synthesized sweeper  
Measuring receiver (*used as a power meter*)  
Power sensor, 50 MHz to 26.5 GHz  
Power sensor, 1 MHz to 2.9 GHz  
Power splitter  
Adapter, Type N (m) to APC 3.5 (m)  
Adapter, Type N (f) to APC 3.5 (m)  
Adapter, APC 3.5 (f) to APC 3.5 (f)  
Cable, APC 3.5, 91 cm (36 in.)

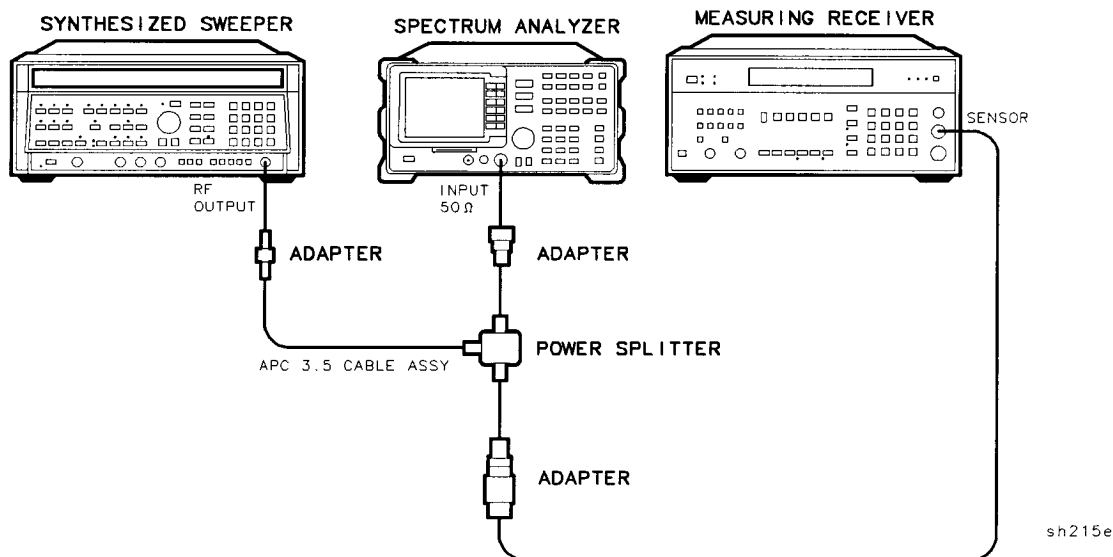


Figure 2-30. Frequency Response Setup

### Procedure

#### Measuring Uncorrected Flatness

1. Zero and calibrate the measuring receiver and 1 MHz to 2.9 GHz power sensor in log mode as described in the measuring receiver operation manual.
2. Connect the equipment as shown in Figure 2-30.
3. Press INSTRUMENT PRESET on the synthesized sweeper. Set the synthesized sweeper controls as follows:

CW ..... 300 MHz  
FREQ STEP ..... 72 MHz  
POWER LEVEL ..... -3 dBm

4. To enter band 0, press the following analyzer keys.

**PRESET**

**CAL** More 1 of 4

**CORRECT ON OFF** (OFF)

**FREQUENCY** BAND LOCK 0 - 2.9 Gz BAND 0 (*Skip these key presses for the HP 8594E, HP 8594L and HP 8594Q analyzers.*)

## 16. Frequency Response of the HP 8592L/94L, HP 8593E/94E/95E/96E, and HP 8594Q

5. Set the analyzer controls by pressing the following keys.

**FREQUENCY** 300 **MHz**  
**CF STEP AUTO MAN (MAN)** 72 **MHz**  
**SPAN** 10 **MHz**  
**AMPLITUDE** 0 **dBm**  
**SCALE LOG LIN (LOG)** 10 **dB**  
**BW** 1 **MHz**  
**PEAK SEARCH**  
**MKR FCTN MKR TRACK ON OFF (ON)**

6. Adjust the synthesized sweeper POWER LEVEL for a MKR-TRK amplitude reading of  $-9 \text{ dBm} \pm 0.1 \text{ dB}$  on the analyzer.
7. Press RATIO on the measuring receiver.

### Band 0

8. Set the synthesized sweeper CW to 12 MHz.
9. Press the following analyzer keys.

**FREQUENCY** 12 **MHz**

10. Adjust the synthesized sweeper POWER LEVEL for a MKR-TRK amplitude reading of  $-9 \text{ dBm} \pm 0.1 \text{ dB}$  on the analyzer.
11. Record the power ratio displayed on the measuring receiver in Column 2 of Table 2-10.
12. On the synthesized sweeper, press CW and STEP UP.
13. On the analyzer, press the following keys.

**FREQUENCY** **↑**

14. Step through the remaining frequencies listed in Table 2-10. At each new frequency, repeat steps 10 through 13 and enter the appropriate power sensor cal factor into the measuring receiver as listed in Column 3 of Table 2-10.

Adjustment for the HP 8594E and HP 8594L spectrum analyzer and HP 8594Q QAM analyzer is complete. Continue with "Entering Flatness Correction Data" at the end of this adjustment.

Continue with the next step for all other analyzers.

### Band 1

15. Replace the 1 MHz to 2.9 GHz power sensor with the 50 MHz to 26.5 GHz power sensor.
16. Calibrate the measuring receiver and 50 MHz to 26.5 GHz power sensor combination in log mode.
17. Set the synthesized sweeper CW to 300 MHz.
18. Press the following analyzer keys.

**FREQUENCY** 300 **MHz**

19. Adjust the synthesized sweeper POWER LEVEL for a MKR-TRK amplitude reading of  $-9 \text{ dBm} \pm 0.1 \text{ dB}$  on the analyzer.
20. Press RATIO on the measuring receiver.
21. To enter band 1, press the following analyzer keys.

## 16. Frequency Response of the HP 8592L/94L, HP 8593E/94E/95E/96E, and HP 8594Q

**FREQUENCY** BAND LOCK 2.75 - 6.4 BAND 1

22. Set the analyzer controls by pressing the following keys.

**FREQUENCY** 2.75 **GHz**

CF STEP AUTO MAN (MAN) 234.9 **MHz**

**SPAN** 10 **MHz**

**BW** 1 **MHz**

23. Set the synthesized sweeper CW to 2.75 GHz and FREQ STEP to 234.3 MHz.

24. Press the following analyzer keys.

**PEAK SEARCH**

**MKR FCTN** MK TRACK ON OFF (ON)

**AMPLITUDE** PRESEL PEAK

25. Adjust the synthesized sweeper POWER LEVEL for a MKR-TRK amplitude reading of  $-9 \text{ dBm} \pm 0.1 \text{ dB}$  on the analyzer.
26. Record the power ratio displayed on the measuring receiver in Column 2 of Table 2-11.
27. On the synthesized sweeper, press CW and STEP UP.
28. On the analyzer, press the following keys.

**FREQUENCY** **↑**

29. Step through the remaining frequencies listed in Table 2-11. At each new frequency, repeat steps 24 through 28 and enter the appropriate power sensor cal factor into the measuring receiver as listed in Column 3 of Table 2-11.

Adjustment for the HP 8595E spectrum analyzer is complete. Continue with "Entering Flatness Correction Data" at the end of this adjustment.

Continue with the next step for all other analyzers.

## Band 2

30. To enter band 2, press the following analyzer keys.

**FREQUENCY** BAND LOCK 6.0-12.8 BAND 2

31. Set the analyzer controls by pressing the following keys.

**FREQUENCY** 6.2 **GHz**

CF STEP AUTO MAN (MAN) 184 **MHz**

**SPAN** 10 **MHz**

**BW** 1 **MHz**

32. Set the synthesized sweeper CW to 6.2 GHz and FREQ STEP to 184 MHz.

33. Press the following analyzer keys.

**PEAK SEARCH**

**MKR FCTN** MK TRACK ON OFF (ON)

**AMPLITUDE** PRESEL PEAK

34. Adjust the synthesized sweeper POWER LEVEL for a MKR-TRK amplitude reading of  $-15 \text{ dBm} \pm 0.1 \text{ dB}$  on the analyzer.

## 16. Frequency Response of the HP 8592L/94L, HP 8593E/94E/95E/96E, and HP 8594Q

35. Add 6 dB to the power ratio displayed on the measuring receiver and record the result in Table 2-13.

For example, if the power ratio displayed on the measuring receiver is +2.8 dB, enter 8.8 dB (Error = 2.8 dB + 6.0 dB = 8.8 dB). The 6 dB correction comes from the difference between the MKR-TRK amplitudes set in step 6 (-9 dBm) and step 34 (-15 dBm).

36. On the synthesized sweeper, press CW and STEP UP.  
37. Press the following analyzer keys.

**FREQUENCY**  $\uparrow$

38. Step through the remaining frequencies listed in Table 2-12. At each new frequency, repeat steps 33 through 37 and enter the appropriate power sensor cal factor into the measuring receiver as listed in Column 3 of Table 2-12.

Adjustment for the HP 8596E spectrum analyzer is complete. Continue with "Entering Flatness Correction Data" at the end of this adjustment.

Continue with the next step for all other analyzers.

### Band 3

39. To enter band 3, press the following analyzer keys.

**FREQUENCY** **BAND LOCK** 12.4-19. **BAND 3**

40. Set the controls of the analyzer by pressing the following keys.

**FREQUENCY** 12.45 **GHz**  
**CF STEP AUTO MAN (MAN)** 230 **MHz**  
**SPAN** 10 **MHz**  
**BW** 1 **MHz**

41. Set the synthesized sweeper CW to 12.45 GHz and FREQ STEP to 230 MHz.  
42. Press the following analyzer keys.

**PEAK SEARCH**  
**MKR FCTN** **MK TRACK ON OFF (ON)**  
**AMPLITUDE** **PRESEL PEAK**

43. Adjust the synthesized sweeper POWER LEVEL for a MKR-TRK amplitude reading of -20 dBm  $\pm$ 0.1 dB on the analyzer.

44. Add 11 dB to the power ratio displayed on the measuring receiver and record the result in Table 2-13. For example, if the power ratio displayed on the measuring receiver is 6.7 dB, enter 17.7 dB (Error = 6.7 dB + 11.0 dB = 17.7 dB). The 11 dB correction comes from the difference between the MKR-TRK amplitudes set in step 6 (-9 dBm) and step 43 (-20 dBm).

45. On the synthesized sweeper, press CW and STEP UP.  
46. Press the following analyzer keys.

**FREQUENCY**  $\uparrow$

47. Step through the remaining frequencies listed in Table 2-13. At each new frequency, repeat steps 42 through 46 and enter the appropriate power sensor cal factor into the measuring receiver as listed in Column 3 of Table 2-13.

## 16. Frequency Response of the HP 8592L/94L, HP 8593E/94E/95E/96E, and HP 8594Q

### Band 4

48. To enter band 4, press the following analyzer keys.

**(MKR)** MARKERS OFF

**(SPAN)** BAND LOCK 19.1-22 BAND 4 (*Option:026* 19.1-26.5 BAND 4)

49. Set the controls on the analyzer by pressing the following keys.

**(FREQUENCY)** 19.15 **(GHz)**

CF STEP AUTO MAN (MAN) 150 **(MHz)** (*Option 026:* 148 **(MHz)**.)

**(SPAN)** 5 **(MHz)**

**(BW)** 1 **(MHz)**

VID BW AUTO MAN (MAN) 300 **(Hz)**

50. Set the synthesized sweeper CW to 19.15 GHz and FREQ STEP to 150 MHz (*Option 026:* 148 MHz).

51. Press the following analyzer keys.

**(PEAK SEARCH)**

**(MKR FCTN)** MK TRACK ON OFF (ON)

**(AMPLITUDE)** PRESEL PEAK

52. Adjust the synthesized sweeper POWER LEVEL for a MKR-TRK amplitude reading of  $-34 \text{ dBm} \pm 0.1 \text{ dB}$  on the analyzer.

53. Add 25 dB to the power ratio displayed on the measuring receiver and record the result in Table 2-14 (*Option 026:* Table 2-15).

For example, if the power ratio displayed on the measuring receiver is  $-3.4 \text{ dB}$ , enter 21.6 dB (Error =  $-3.4 \text{ dB} + 25.0 \text{ dB} = 21.6 \text{ dB}$ ). The 25 dB correction comes from the difference between the MKR-TRK amplitudes set in step 6 ( $-9 \text{ dBm}$ ) and step 52 ( $-34 \text{ dBm}$ ).

54. On the synthesized sweeper, press CW and STEP UP.

55. Press the following analyzer keys.

**(MKR)** MARKERS OFF

**(FREQUENCY)** **(↑)**

56. Step through the remaining frequencies listed in Table 2-14 (*Option 026:* Table 2-15). At each new frequency, repeat steps 51 through 55 and enter the appropriate power sensor cal factor into the measuring receiver as listed in Column 2 of Table 2-14 (*Option 026:* Table 2-15).

Adjustment for the HP 8592L and HP 8593E spectrum analyzers is complete. Continue with the next step.

## 16. Frequency Response of the HP 8592L/94L, HP 8593E/94E/95E/96E, and HP 8594Q

### Entering Flatness Correction Data

57. Enter the pass code by pressing the following analyzer keys.

PRESET  
FREQUENCY -2001 Hz

58. To access the flatness correction menu, press the following analyzer keys.

CAL More 1 of 4 More 2 of 4  
SERVICE CAL  
FLATNESS DATA

---

**Caution** The next step will erase all current flatness correction. This step is to be performed *only if* the A16 processor/video assembly has been repaired or replace.

---

59. Initialize the area of memory where the flatness correction data is stored, by pressing the following keys.

INIT FLT 22 GHz For Option 026, 027 only: Use INIT FLT 26.5 GHz  
PRESET  
FREQUENCY -2001 Hz  
CAL More 1 of 4 More 2 of 4  
SERVICE CAL  
FLATNESS DATA

60. Enter the flatness corrections, by pressing **EDIT FLATNESS**.
61. The frequency of the first data point, 12.00 MHz, will be displayed in the active function block of the analyzer display.
62. Use the data keys on the analyzer to enter the amplitude value for 12 MHz from Column 2 of Table 2-10, Frequency Response Errors. Terminate the entry with the **dB** key. When entering negative amplitude values, precede the numeric entry with the **-** and **dB** keys or the **-dB** key.
- Note that the **BK SP** (backspace) key may be used to correct any entry if the terminator, **dB** or **-dB** key has *not* been pressed. Re-enter the data if the terminator has been pressed.
63. Press **↑** (step up) and enter the data from Column 2 of the “Frequency Response Errors” tables for the next data point as described in step 61.
64. Repeat step 62 for the remaining flatness correction data points listed in the “Frequency Response Errors” tables. At each point, verify that the frequency listed in the active function block corresponds to the frequency at which the data was taken. If these two frequencies do not correspond, press **↑** (step up) or **↓** (step down) until the proper frequency is displayed in the active function block.
- If some data is incorrect after entering all of the data from the “Frequency Response Errors” tables, select the incorrect data point using **↑** (step up) or **↓** (step down) and re-enter the proper data.

65. After all corrections have been input, press **STORE FLATNESS** to store the correction data in nonvolatile memory. The instrument will automatically preset and display **CAL: DONE** in the active function block of the analyzer.

**16. Frequency Response of the HP 8592L/94L, HP 8593E/94E/95E/96E, and HP 8594Q**

**Table 2-10. Frequency Response Errors Band 0**

<b>Column 1 Frequency (GHz)</b>	<b>Column 2 Measuring Receiver Reading (dB)</b>	<b>Column 3 CAL FACTOR Frequency (GHz)</b>
0.012	_____	0.05
0.084	_____	0.05
0.156	_____	0.05
0.228	_____	0.05
0.300	_____	0.05
0.372	_____	0.05
0.444	_____	0.05
0.516	_____	0.05
0.588	_____	0.05
0.660	_____	0.05
0.732	_____	0.05
0.804	_____	0.05
0.876	_____	0.05
0.948	_____	0.05
1.020	_____	0.05
1.092	_____	2.0
1.164	_____	2.0
1.236	_____	2.0
1.308	_____	2.0
1.380	_____	2.0
1.452	_____	2.0
1.524	_____	2.0
1.596	_____	2.0
1.668	_____	2.0
1.740	_____	2.0
1.812	_____	2.0
1.884	_____	2.0



**16. Frequency Response of the HP 8592L/94L, HP 8593E/94E/95E/96E, and HP 8594Q**

**Table 2-10. Frequency Response Errors Band 0 (continued)**

<b>Column 1 Frequency (GHz)</b>	<b>Column 2 Measuring Receiver Reading (dB)</b>	<b>Column 3 CAL FACTOR Frequency (GHz)</b>
1.956	_____	2.0
2.028	_____	2.0
2.100	_____	2.0
2.172	_____	2.0
2.244	_____	2.0
2.316	_____	2.0
2.388	_____	2.0
2.460	_____	2.0
2.532	_____	3.0
2.604	_____	3.0
2.676	_____	3.0
2.748	_____	3.0
2.820	_____	3.0
2.892	_____	3.0

**16. Frequency Response of the HP 8592L/94L, HP 8593E/94E/95E/96E, and HP 8594Q**

**Table 2-11. Frequency Response Errors Band 1**

<b>Column 1 Frequency (GHz)</b>	<b>Column 2 Measuring Receiver Reading (dB)</b>	<b>Column 3 CAL FACTOR Frequency (GHz)</b>
2.7500	_____	3.0
2.9849	_____	3.0
3.2198	_____	3.0
3.4547	_____	3.0
3.6896	_____	4.0
3.9245	_____	4.0
4.1594	_____	4.0
4.3943	_____	4.0
4.6292	_____	4.0
4.8641	_____	5.0
5.0990	_____	5.0
5.3339	_____	5.0
5.5688	_____	5.0
5.8037	_____	6.0
6.0386	_____	6.0
6.2735	_____	6.0
6.5084	_____	6.0

**Table 2-12. Frequency Response Errors Band 2**

<b>Column 1 Frequency (GHz)</b>	<b>Column 2 Measuring Receiver Reading (dB)</b>	<b>Column 3 CAL FACTOR Frequency (GHz)</b>
6.100	_____	6.0
6.284	_____	6.0
6.468	_____	6.0
6.652	_____	7.0
6.836	_____	7.0
7.020	_____	7.0
7.204	_____	7.0
7.388	_____	7.0
7.572	_____	8.0

**16. Frequency Response of the HP 8592L/94L, HP 8593E/94E/95E/96E, and HP 8594Q**

**Table 2-12. Frequency Response Errors Band 2 (continued)**

<b>Column 1 Frequency (GHz)</b>	<b>Column 2 Measuring Receiver Reading (dB)</b>	<b>Column 3 CAL FACTOR Frequency (GHz)</b>
7.756	_____	8.0
7.940	_____	8.0
8.124	_____	8.0
8.308	_____	8.0
8.492	_____	8.0
8.676	_____	9.0
8.860	_____	9.0
9.044	_____	9.0
9.228	_____	9.0
9.412	_____	9.0
9.596	_____	10.0
9.780	_____	10.0
9.964	_____	10.0
10.148	_____	10.0
10.332	_____	10.0
10.516	_____	11.0
10.700	_____	11.0
10.884	_____	11.0
11.068	_____	11.0
11.252	_____	11.0
11.436	_____	11.0
11.620	_____	12.0
11.804	_____	12.0
11.988	_____	12.0
12.172	_____	12.0
12.356	_____	12.0
12.540	_____	13.0
12.724	_____	13.0

16. Frequency Response of the HP 8592L/94L, HP 8593E/94E/95E/96E, and HP 8594Q

Table 2-13. Frequency Response Errors Band 3

Column 1 Frequency (GHz)	Column 2 Measuring Receiver Reading (dB)	Column 3 CAL FACTOR Frequency (GHz)
12.450	_____	12.0
12.680	_____	13.0
12.910	_____	13.0
13.140	_____	13.0
13.370	_____	13.0
13.600	_____	14.0
13.830	_____	14.0
14.060	_____	14.0
14.290	_____	14.0
14.520	_____	15.0
14.750	_____	15.0
14.980	_____	15.0
15.210	_____	15.0
15.440	_____	15.0
15.670	_____	16.0
15.900	_____	16.0
16.130	_____	16.0
16.360	_____	16.0
16.590	_____	17.0
16.820	_____	17.0
17.050	_____	17.0
17.280	_____	17.0
17.510	_____	18.0
17.740	_____	18.0
17.970	_____	18.0
18.200	_____	18.0
18.430	_____	18.0
18.660	_____	19.0
18.890	_____	19.0
19.120	_____	19.0
19.350	_____	19.0

**16. Frequency Response of the HP 8592L/94L, HP 8593E/94E/95E/96E, and HP 8594Q**

**Table 2-14. Frequency Response Errors Band 4**

<b>Column 1 Frequency (GHz)</b>	<b>Column 2 Measuring Receiver Reading (dB)</b>	<b>Column 3 CAL FACTOR Frequency (GHz)</b>
19.150	_____	19.0
19.300	_____	19.0
19.450	_____	19.0
19.600	_____	20.0
19.750	_____	20.0
19.900	_____	20.0
20.050	_____	20.0
20.200	_____	20.0
20.350	_____	20.0
20.500	_____	20.0
20.650	_____	21.0
20.800	_____	21.0
20.950	_____	21.0
21.100	_____	21.0
21.250	_____	21.0
21.400	_____	21.0
21.550	_____	22.0
21.700	_____	22.0
21.850	_____	22.0
22.000	_____	22.0

16. Frequency Response of the HP 8592L/94L, HP 8593E/94E/95E/96E, and HP 8594Q

Table 2-15. Frequency Response Errors Band 4 (Option 026)

Column 1 Frequency (GHz)	Column 2 Measuring Receiver Reading (dB)	Column 3 CAL FACTOR Frequency (GHz)
19.100	_____	19.0
19.248	_____	19.0
19.396	_____	19.0
19.544	_____	20.0
19.692	_____	20.0
19.840	_____	20.0
19.988	_____	20.0
20.136	_____	20.0
20.284	_____	20.0
20.432	_____	20.0
20.580	_____	21.0
20.728	_____	21.0
20.876	_____	21.0
21.024	_____	21.0
21.172	_____	21.0
21.320	_____	21.0
21.468	_____	21.0
21.616	_____	22.0
21.764	_____	22.0
21.912	_____	22.0
22.060	_____	22.0
22.208	_____	22.0
22.356	_____	22.0
22.504	_____	23.0
22.652	_____	23.0
22.800	_____	23.0
22.948	_____	23.0
23.096	_____	23.0

16. Frequency Response of the HP 8592L/94L, HP 8593E/94E/95E/96E, and HP 8594Q

Table 2-15. Frequency Response Errors Band 4 (*Option 026*) (continued)

Column 1 Frequency (GHz)	Column 2 Measuring Receiver Reading (dB)	Column 3 CAL FACTOR Frequency (GHz)
23.244	_____	23.0
23.392	_____	23.0
23.540	_____	24.0
23.688	_____	24.0
23.836	_____	24.0
23.984	_____	24.0
24.132	_____	24.0
24.280	_____	24.0
24.428	_____	24.0
24.576	_____	25.0
24.724	_____	25.0
24.872	_____	25.0
25.020	_____	25.0
25.168	_____	25.0
25.316	_____	25.0
25.464	_____	25.0
25.612	_____	26.0
25.760	_____	26.0
25.908	_____	26.0
26.056	_____	26.0
26.204	_____	26.0
26.352	_____	26.5
26.500	_____	26.5

---

## 17. Time and Date

### This adjustment applies to:

All HP 8590 E-Series and L-Series spectrum analyzers  
HP 8591C cable TV analyzers  
HP 8594Q QAM analyzers

The time and date are displayed in the top left corner of the display when the timedate mode is activated. The time and date are changed using the front-panel keys.

### Procedure

1. To turn the time and date ON or OFF, press the following analyzer keys.

**CONFIG**

**TIMEDATE**

**TIMEDATE ON OFF** (ON) or (OFF) as desired

The time and date will be displayed in the top-left corner with ON underlined.

2. The time and date may be displayed as month, day, and year (MDY) or as day, month, and year (DMY). To change the display, press the following analyzer keys.

**CONFIG**

**TIMEDATE**

**DATEMODE MDY DMY** (MDY) or (DMY) as desired

3. To change the date, press the following analyzer keys.

**CONFIG**

**TIMEDATE**

**SET DATE**

The active function block of the analyzer will display YYMMDD (year, month, and day). Use the data keys on the analyzer to enter the correct date as YYMMDD. Terminate the entry with one of the **ENTER** data keys.

4. To change the time, press the following analyzer keys.

**CONFIG**

**TIMEDATE**

**SET TIME**

The active function block of the analyzer will display HHMMSS (hours, minutes, and seconds). Use the data keys on the analyzer to enter the correct time as HHMMSS. Terminate the entry with one of the **ENTER** data keys.



---

## 18. Modulator Offset and Gain for Option 010 or 011

### This adjustment applies to:

HP 8590L spectrum analyzers, Option 010 or 011  
 HP 8591E spectrum analyzers, Option 010 or 011  
 HP 8591C cable TV analyzers, Option 011

The gain and offset of the modulator is adjusted with the internal Automatic Level Control disabled. The modulator test point on the A7A1 tracking generator control assembly is multiplexed onto test point A7TP2 located on the A7 Analog Interface assembly. This is done by executing the command MOD\_TP in screen title mode.

### Equipment Required

Digital multimeter (DMM)  
 DMM test leads  
 Adapter, Type N (m) to BNC (f) (*two required*)  
 Cable, BNC, 50  $\Omega$

### Additional Equipment for Option 011

Cable, BNC, 75  $\Omega$

### Procedure

1. Switch the analyzer on and let it warm up 30 minutes.
2. Connect the BNC cable to the analyzer CAL OUT to the RF INPUT connector.

---

**Caution** Use only 75  $\Omega$  cables, connectors, or adapters on instruments equipped with 75  $\Omega$  inputs or damage to the input connectors will occur.

---

3. Press **PRESET**, then perform the CAL AMPTD and CAL FREQ adjustment routines. Refer to “CAL AMPTD Adjustment Routine” and “CAL FREQ Adjustment Routine” procedures.

It is normal for FREQ UNCAL to appear on the display. This will disappear after the CAL routines are finished.

Note that if the display shows CAL SIGNAL NOT FOUND, the routines default settings are not sufficient to find the signal. Press **FREQ** -37 **Hz** before performing the CAL routines. This causes the routines to bypass the CAL signal check.

4. Press **CAL STORE** on the analyzer.

---

**Caution** Use only 75  $\Omega$  cables, connectors, or adapters on instruments equipped with 75  $\Omega$  inputs or damage to the input connectors will occur.

---

5. Connect the analyzer RF OUT to the RF INPUT using a BNC cable and adapters.
6. Perform the tracking generator self-cal routine by pressing the following analyzer keys.

**CAL** More 1 of 4 More 2 of 4 CAL TRK GEN

Wait for the completion of the routine (less than 1 minute).

7. Press **CAL STORE**.

## 18. Modulator Offset and Gain for Option 010 or 011

8. Press **PRESET**, then wait for preset routine to finish. Set the analyzer by pressing the following keys.

**FREQUENCY** 300 **MHz**  
**SPAN** 0 **Hz**

75  $\Omega$  only: Press **AMPLITUDE**, **More 1 of 2**, **AMPTD UNITS**, **dBm**.

Set the analyzer reference level to +12 dBm.

9. Press the following analyzer keys.

**AUX CTRL** **TRACK GEN SRC PWR ON OFF (ON)**  
**CAL** **More 1 of 4** **More 2 of 4**  
**SERVICE DIAG** **More 1** **More 2** **More 3** **More 4** **More 5**  
**ALC TEST**

This breaks the ALC loop, causing TG UNLVL to appear on the screen; this is normal.

10. Connect the ground (-) lead of the DMM to A7TP1. Connect the positive (+) lead to A7TP2.
11. Adjust A7A1R43 and A7A1R49 fully clockwise.
12. Connect the MOD\_TP test point, located on the A7A1 tracking generator control assembly, to A7TP2 by pressing **DISPLAY** **CHANGE TITLE**, then type in the following:

DET TGMOD;

13. Press the following analyzer keys to execute the screen title command.

**CAL** **More 1 of 4** **More 2 of 4**  
**SERVICE CAL**  
**EXECUTE TITLE**

Note that TGMOD should appear in the upper-left screen annotation below REF.

14. Press the following analyzer keys.

**AMPLITUDE** **SCALE LOG LIN (LOG) 1** **dB**  
**AUX CTRL** **TRACK GEN SRC PWR ON OFF (ON)**

15. Adjust the front-panel knob for 0.0 V  $\pm$ 0.01 V on the DMM, then press the following keys.

**TRACE** **CLEAR WRITE A** **More 1 of 3** **DETECTOR SAMPL PK (PK)**  
**MKR** **MARKER  $\Delta$**

16. Adjust A7A1R49 so that the MKR reading drops approximately 0.1 to 0.15 dB.

17. Press the following analyzer keys.

**MKR** **MARKER  $\Delta$**  **MARKER  $\Delta$**   
**CAL** **More 1 of 4** **More 2 of 4** **SERVICE CAL** **EXECUTE TITLE**  
**AMPLITUDE** **SCALE LOG LIN (LOG) 10** **dB**  
**AUX CTRL** **TRACK GEN SRC PWR ON OFF (ON)**

## 18. Modulator Offset and Gain for Option 010 or 011

18. Adjust the front-panel knob for  $-1.0\text{ V} \pm 0.01\text{ V}$  measured with the DMM, then press the following analyzer keys.

**TRACE** **CLEAR WRITE A** **More 1 OF 4** **DETECTOR SAMPL PK (PK)**

19. Adjust A7A1R43 so that the MARKER DELTA reading is  $-33\text{ dB} \pm 0.5\text{ dB}$ .
20. Press **PRESET**, then wait for the preset routine to finish.
21. Perform the tracking generator self-cal routine by pressing the following analyzer keys.

**CAL** **More 1 of 4** **More 2 of 4** **CAL TRK GEN**

Wait for the completion of the routine (less than 1 minute).

22. Press **CAL STORE**.

---

## 19. Entering External ALC Correction Constants for Option 010 or 011

This adjustment applies to:

- HP 8590L spectrum analyzers, Option 010 or 011
- HP 8591E spectrum analyzers, Option 010 or 011
- HP 8591C cable TV analyzers, Option 011

External automatic level control (ALC) operation is corrected by entering the correction constants (CALTGX slope and offset) into analyzer memory using the EXECUTE TITLE function.

Correction constants that pertain to each tracking generator are developed at the factory. The two constants are recorded on a label which is located on the A7A1 tracking generator control board assembly.

### Equipment Required

No equipment is required for this procedure.

### Procedure

- Record the CAL TGX slope and offset numbers (located on the A7A1 assembly) below.

Slope = \_\_\_\_\_  
Offset = \_\_\_\_\_

- Press the following analyzer keys: `DISPLAY CHANGE TITLE More 1 of 2`.
- Enter the CALTGX slope and offset correction constants in the format `CALTGX slope,offset`. For example, a slope of 0.3079 and an offset of 3095 would be entered as:

```
CALTGX 0.3079,3095;
```

- Press the following analyzer keys.

```
CAL More 1 of 4 More 2 of 4 SERVICE CAL EXECUTE TITLE
```

```
CAL More 1 of 4 More 2 of 4 SERVICE DIAG DISPLAY CAL DATA NEXT PAGE
```

Verify that the XSLOP and XOFST values are the same as you entered in step 3.

- Perform the "Checking the External ALC for Option 010 or 011" procedure.

---

## 20. Checking the External ALC for Option 010 or 011

**This adjustment applies to:**

HP 8590L spectrum analyzers, Option 010 or 011  
 HP 8591E spectrum analyzers, Option 010 or 011  
 HP 8591C cable TV analyzers, Option 011

External automatic level control (ALC) operation is verified by measuring the power necessary to level the tracking generator at a source power of 0 dBV and  $-34$  dBV. There are no specifications for this adjustment. The limit set for verification is  $\pm 0.75$  dBV.

Note that if the analyzer does not pass this procedure, or if the factory correction constants are not available, perform the “Correcting for External ALC Error for Option 010 or 011” procedure in this chapter.

**Equipment Required**

Digital multimeter (DMM)  
 Power meter  
 Power sensor, 1 MHz to 350 MHz  
 Cable, BNC (m) to dual banana plug  
 Cable, BNC, 122 cm (48 in)  
 Cable, BNC, 23 cm (9 in)  
 Adapter, BNC Tee  
 Adapter, Type N (m) to BNC (f) (*two required*)

**Additional Equipment for Option 011**

Power sensor, 75  $\Omega$   
 Cable, BNC, 75  $\Omega$   
 Adapter, 75  $\Omega$ , Type N (f) to BNC (m)

**Procedure**

1. Switch the analyzer on and let it warm up 30 minutes.
2. Connect the analyzer CAL OUT to the RF INPUT.

---

**Caution** Use only 75  $\Omega$  cables, connectors, or adapters on instruments equipped with 75  $\Omega$  inputs or damage to the input connectors will occur.

---

3. Press **PRESET**, then perform the CAL FREQ and CAL AMPTD adjustment routines. Refer to “CAL FREQ Adjustment Routine” and “CAL AMPTD Adjustment Routine” procedures.

It is normal for FREQ UNCAL to appear on the display. This will disappear after the CAL routines are finished.

Note that if the display shows CAL SIGNAL NOT FOUND, the routines default settings are not sufficient to find the signal. Press **FREQ**  $-37$  **Hz** before performing the CAL routines. This causes the routines to bypass the CAL signal check.

4. Press **CAL STORE** on the analyzer.
5. Connect a BNC cable from the RF INPUT to the RF OUTPUT.
6. Press **PRESET**, then wait for preset routine to finish.

## 20. Checking the External ALC for Option 010 or 011

7. Perform the tracking generator self-cal routine by pressing the following analyzer keys.

**CAL** More 1 of 4 More 2 of 4 CAL TRK GEN

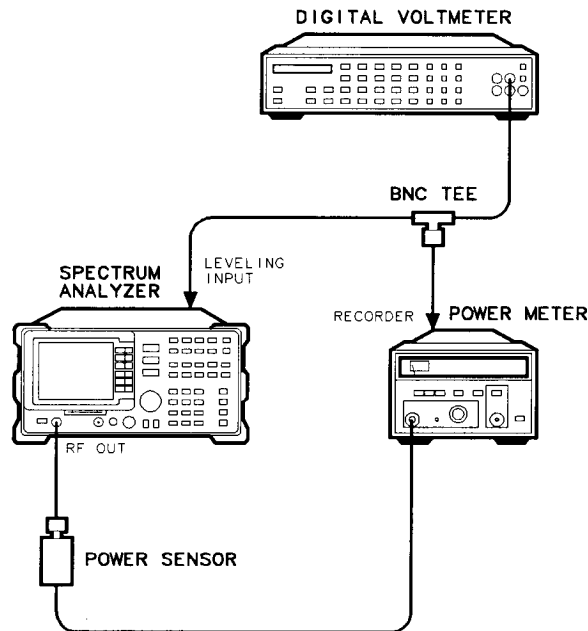
Wait for the completion of the routine (less than 1 minute).

8. Press **CAL STORE**.
9. Zero and calibrate the power meter and power sensor as described in the power meter operation manual.

---

**Caution** Use only 75  $\Omega$  cables, connectors, or adapters on instruments equipped with 75  $\Omega$  inputs or damage to the input connectors will occur.

---



sh231e

**Figure 2-31. External ALC Verification Adjustment**

10. Connect the equipment as shown in Figure 2-31. *For Option 011 only:* Use the 75  $\Omega$  power sensor with an adapter, instead of the 50  $\Omega$  power sensor.

*75  $\Omega$  only:* Press **AMPLITUDE**, More 1 of 2, **AMPTD UNITS**, dBm.

11. Set the DMM to measure dc volts.
12. Set the analyzer by pressing the following keys.

**FREQUENCY** 300 **MHz**

**SPAN** 0 **Hz**

**AUX CTRL** TRACK GEN SRC PWR ON OFF (ON) 2 **-dBm**.

13. Ensure that the power meter reads  $-2 \pm 2$  dB, then press **RANGE HOLD** on the power meter.
14. On the analyzer, press More 1 OF 2 **ALC MTR INT XTAL** (MTR).
15. Adjust the SRC PWR for 0 dBV by turning the front-panel knob on the analyzer. Note that the display will read the power dBm.

## 20. Checking the External ALC for Option 010 or 011

16. Note the voltage on the DMM. This is the error at source power 0 dBV. Record the automatic leveling control (ALC) voltage in the space provided.

ALC voltage at 0 dBV# = \_\_\_\_\_volts dc

17. Convert the ALC voltage recorded in the previous step to dBv using the following equation.

$$\text{ALC Voltage in dBv} = 20 \log (V)$$

The calculated ALC voltage, in dBV, should be  $\geq -0.75$  dBV and  $\leq +0.75$  dBV.

18. Adjust the SRC PWR to  $-34$  dBV using the front-panel knob. (Display reads  $-34$  dBm.)
19. Note the voltage on the DMM. Wait until the reading stabilizes before recording it in the space provided. This is the error at a source power of  $-34$  dBV.

ALC voltage at  $-34$  dBV = \_\_\_\_\_volts dc

20. Convert the ALC voltage recorded in the previous step using the following equation.

$$\text{ALC voltage in dBV} = 20 \log (V)$$

The calculated ALC voltage, in dBV, should be greater than or equal to  $-34.75$  dBV and less than or equal to  $-33.25$  dBV.

---

## 21. Correcting for External ALC Error for Option 010 or 011

### This adjustment applies to:

HP 8590L spectrum analyzers, Option 010 or 011  
HP 8591E spectrum analyzers, Option 010 or 011  
HP 8591C cable TV analyzers, Option 011

External automatic level control (ALC) operation is corrected by developing two correction constants (CALGX Slope and Offset).

This procedure is only necessary if the "Checking the External ALC for Option 010 or 011" procedure does not pass, or if the factory correction constants are not available.

### Equipment Required

Digital multimeter (DMM)  
Power meter  
Power sensor, 1 MHz to 350 MHz  
Cable, BNC (m) to dual banana plug  
Adapter, BNC Tee  
Adapter, Type N (m) to BNC (f) (*two required*)  
Cable, BNC, 122 cm (48 in)  
Cable, BNC, 32 cm (9 in)

### Additional Equipment for Option 011

Power sensor, 75  $\Omega$   
Cable, BNC, 75  $\Omega$   
Adapter, 75  $\Omega$ , Type N (f) to BNC (m)

### Procedure

1. Connect a BNC cable from the RF INPUT to the RF OUTPUT.

---

**Caution** Use only 75  $\Omega$  cables, connectors, or adapters on instruments equipped with 75  $\Omega$  inputs or damage to the input connectors will occur.

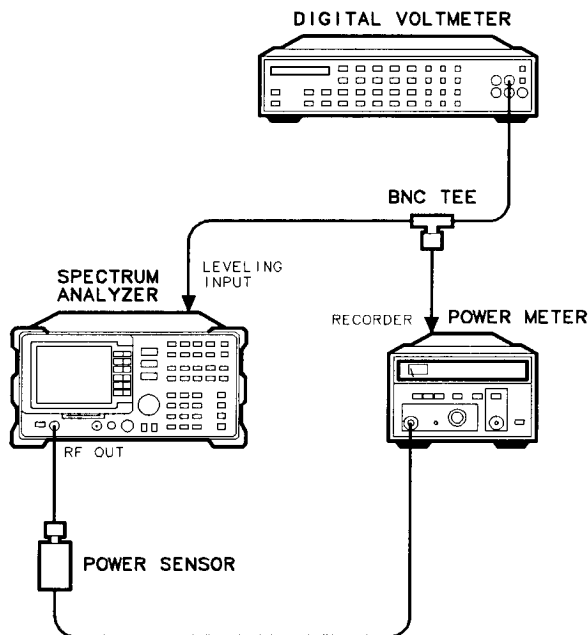
---

2. Press **PRESET**, then wait for preset routine to finish.
3. Perform the tracking generator self-cal routine by pressing the following analyzer keys.  
**CAL** More 1 of 4 More 2 of 4 CAL TRK GEN  
Wait for the completion of the routine (less than 1 minute).
4. Press **CAL STORE**.
5. Zero and calibrate the power meter and power sensor as described in the power meter operation manual.



## 21. Correcting for External ALC Error for Option 010 or 011

**Caution** Use only 75  $\Omega$  cables, connectors, or adapters on instruments equipped with 75  $\Omega$  inputs or damage to the input connectors will occur.



sh231e

**Figure 2-32. External ALC Error Correction Adjustment**

6. Connect the equipment as shown in Figure 2-32. *For Option 011 only:* Use the 75  $\Omega$  power sensor with an adapter, instead of the 50  $\Omega$  power sensor.

*Option 011 only:* Press **AMPLITUDE**, **More 1 of 2**, **AMPTD UNITS**, **dBm**.

7. Set the DMM to measure dc volts.

**Caution** The default values must be entered first for the correction procedure to be successful.

8. Load the default correction constants for Slope and Offset into nonvolatile memory by performing the following steps.

- Press the following analyzer keys.

**DISPLAY** **CHANGE TITLE**

- Enter the following screen title.

CALTGX 0.3079,3095;

- Press the following analyzer keys.

**CAL** **More 1 OF 4** **More 2 OF 4** **SERVICE CAL EXECUTE TITLE**

**CAL** **More 1 OF 4** **More 2 OF 4** **SERVICE DIAG NEXT PAGE**

Verify that the XSLOP and XOFST values are the same as you entered in the previous step.

## 21. Correcting for External ALC Error for Option 010 or 011

9. Set the analyzer by pressing the following keys.

**FREQUENCY** 300 **MHz**

**SPAN** 0 **Hz**

**AUX CTRL** TRACK GEN SRC PWR ON OFF (ON) 2 **-dBm**.

10. Ensure that the power meter reads  $-2 \pm 2$  dBm. Press **RANGE HOLD** on the HP 436A Power Meter.
11. On the analyzer, press **More 1 OF 2 ALC MTR INT XTAL** (until MTR is underlined).
12. Adjust the SRC PWR for 0 dBV as read on the analyzer display. Note that the display will read the power in dBm.
13. Note the voltage on the DMM. Wait until the reading stabilizes before recording it in the space provided. This is the ALC voltage at a source power of 0 dBV ( $V_{High}$ ).

$V_{High} = \text{_____}$  volts dc

14. Adjust the SRC PWR for  $-34$  dBV as read on the analyzer display.
15. Note the voltage on the DMM. Wait until the reading stabilizes before recording it in the space provided. This is the ALC voltage at a source power of  $-34$  dBV ( $V_{Low}$ ).

$V_{Low} = \text{_____}$  volts dc

16. Calculate the actual slope from the two voltage measurements using the following equation.

$$Slope = \frac{10.47}{20 \times \log \frac{V_{High}}{V_{Low}}}$$

Slope = \_\_\_\_\_

For example, if  $V_{High}$  is 0.949V and  $V_{Low}$  is 0.019V, then the slope is 10.47 divided by 33.97, or 0.3082.

17. Calculate the offset from the calculated slope value (step 16) and the measured  $V_{High}$  (step 13) using the following equation.

$$Offset = 3095 - (Slope \times 2000 \times \log (V_{High}))$$

Offset = \_\_\_\_\_

For example, given the same  $V_{High}$  and  $V_{Low}$  values as listed in the slope example.

$$Offset = 3095 - 0.3082 \times -45.47$$

$$Offset = 3095 - (-14.01)$$

$$Offset = 3109$$

18. Enter the calculated Slope and Offset correction constants into nonvolatile memory using the TITLE mode as previously described in step 9.
19. Perform the "Checking the External Leveling" procedure to ensure correct operation.

## 22. First LO Distribution Amplifier for Option 009 or 010

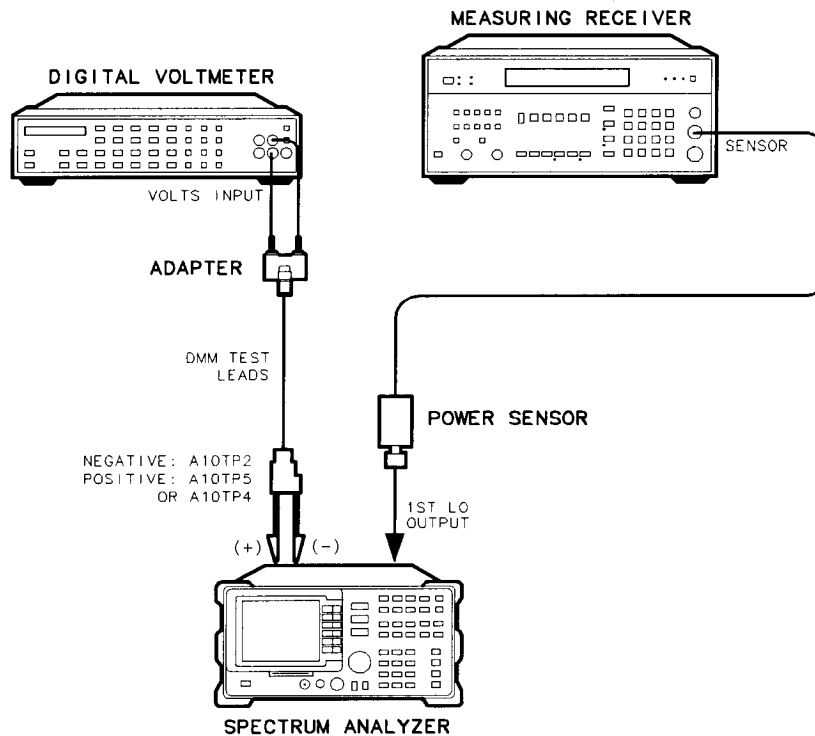
This adjustment applies to:

- HP 8593E spectrum analyzers, Option 009 or 010
- HP 8594E spectrum analyzers, Option 009 or 010
- HP 8595E spectrum analyzers, Option 009 or 010
- HP 8596E spectrum analyzers, Option 009 or 010

The gate bias for the A3A14 LO distribution amplifier assembly is adjusted to the value specified on a label on the RF section. The LO power is adjusted so that the LO SENSE voltage is equal to the value specified on the label. The adjustments are made on the A10 tracking generator control assembly, which is located in the card cage.

### Equipment Required

- Measuring receiver
- Digital multimeter
- Power sensor
- DMM test leads
- Adapter, dual banana plug



sh216e

Figure 2-33. First LO Distribution Amplifier Adjustment Setup

## 22. First LO Distribution Amplifier for Option 009 or 010

### Procedure

1. Set the analyzer **(LINE)** switch to off, then disconnect the line cord. Remove the cover assembly, then reconnect the line cord.
2. Remove the 50  $\Omega$  termination from the analyzer rear-panel LO OUTPUT connector.
3. Connect the positive DMM test lead to A10TP5, GB (gate bias). Connect the negative DMM test lead to A10TP2, AGND (analog ground). See Figure 2-33.
4. Set the digital voltmeter controls as follows:

FUNCTION .....	DC VOLTS
RANGE .....	10 V
RESOLUTION .....	1 mV
5. Set the analyzer **(LINE)** switch to on.
6. Adjust A10R29 (GATE) for a digital voltmeter reading within 5 mV of the GATE (gate bias) voltage printed on the RF section label.
7. Zero and calibrate the measuring receiver and power sensor in LOG mode. (Power levels read in dBm.) Enter the power sensor's 5 GHz cal factor into the measuring receiver.
8. Connect the power sensor to the analyzer LO OUTPUT.
9. On the analyzer, press **(PRESET)**, **(SPAN)**, **ZERO SPAN**, **(FREQUENCY)**, 300, **(MHz)**.
10. Connect the positive DMM test lead to A10TP4, LOS (LO sense).
11. Note the SENS (LO sense) voltage printed on the RF section label. Adjust A10R25, LO AMP (LO power), until the DMM reads equal to the SENS voltage printed on the RF section label.
12. Check that the measuring receiver power level reads greater than +12 dBm.
13. Disconnect the power sensor from LO OUTPUT, then reconnect the 50  $\Omega$  termination to LO OUTPUT.
14. Disconnect the DMM leads from A10TP4 and A10TP2.

## 23. BITG Power Level for Option 010

This adjustment applies to:

- HP 8593E spectrum analyzers, Option 010
- HP 8594E spectrum analyzers, Option 010
- HP 8595E spectrum analyzers, Option 010
- HP 8596E spectrum analyzers, Option 010

The BITG has two adjustments for setting the output power. The  $-10$  dB ADJ (A3A15R13) sets the power level when the source power level is set to  $-10$  dBm, and the 0 dB ADJ (A3A15R18) sets the power level when the source power level is set to 0 dBm. The  $-10$  dB ADJ acts as an offset adjustment, while 0 dB ADJ acts as a gain adjustment.

These adjustments are set in the factory for a 10 dB difference in output power between the  $-10$  dBm and 0 dBm source power level settings. When installing a replacement BITG, it should only be necessary to adjust  $-10$  dB ADJ (the offset adjustment) to account for variations in cable loss from the BITG to the RF OUT 50  $\Omega$  connector. This adjustment is done at a 0 dBm source power level setting. This ensures that the absolute power level with a 0 dBm source power level setting is 0 dBm, with little or no affect on the vernier accuracy.

In some cases, the power level at the  $-10$  dBm source power level setting might be out of tolerance. In such cases, the  $-10$  dB ADJ is set at a source power level setting of  $-10$  dBm and the 0 dB ADJ is set at a source power level setting of 0 dBm. These two adjustments must be repeated until the power level at the two settings are within the given tolerances.

### Equipment Required

- Measuring receiver
- Power sensor, 1 MHz to 350 MHz
- Cable, Type N, 62 cm (24 in.)

### Additional Equipment for Option 026

- Adapter, Type APC-3.5 (f) to APC-3.5 (f) (two)

### Procedure

1. Set the analyzer **LINE** switch to off. Disconnect the line cord. Remove the cover assembly, then reconnect the line cord.
2. Set the analyzer AOFST by pressing the following keys.

```

PRESET
FREQUENCY -2001 Hz
CAL More 1 of 4 More 2 of 4 DEFAULT CAL DATA
CAL More 1 of 4 More 2 of 4
SERV DIAG DISPLAY CAL DATA NEXT PAGE

```

Verify that AOFST=0 under the tracking generator readouts.

3. Connect the cable between the RF OUT 50  $\Omega$  and INPUT 50  $\Omega$  connectors on the analyzer.
4. Press **PRESET** on the analyzer and set the controls as follows:

```

CENTER FREQ ..... 300 MHz
SPAN ..... 0 Hz

```

### 23. BITG Power Level for Option 010

5. On the analyzer, press the following keys.

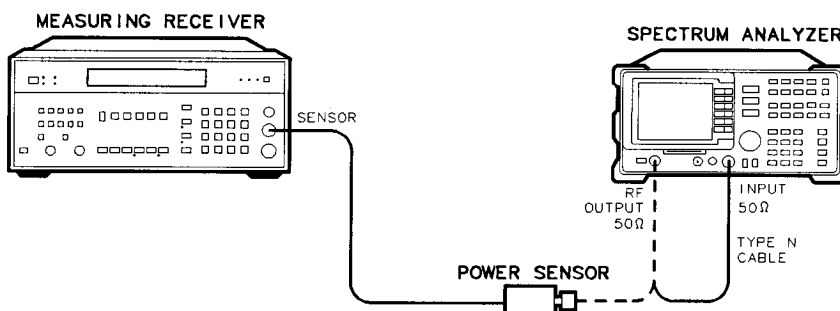
**BW** 10 **kHz**

**AUX CTRL** **TRACK GEN SRC PWR ON OFF** (ON) 10 **-dBm**

6. On the analyzer, press **TRACKING PEAK**. Wait for the **PEAKING** message to disappear.

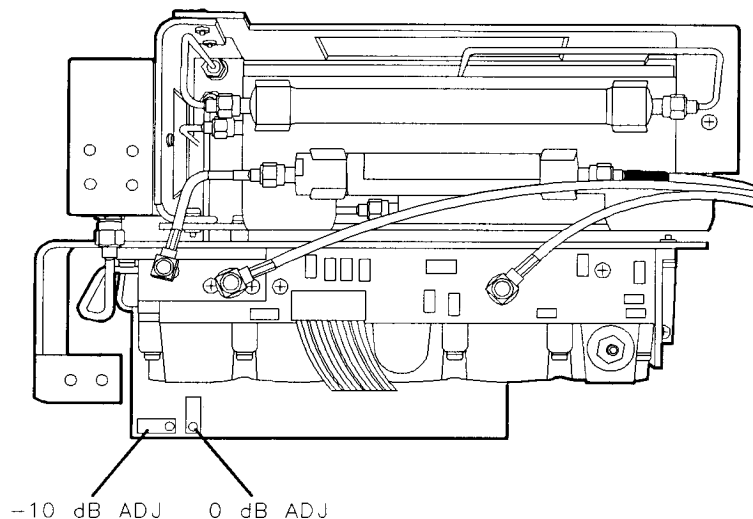
7. Zero and calibrate the measuring-receiver/power-sensor combination in log mode (power levels readout in dBm). Enter the power sensor 300 MHz cal factor into the measuring receiver.

8. Disconnect the cable from the RF OUT 50  $\Omega$  connector, then connect the power sensor to the RF OUT 50  $\Omega$  connector. See Figure 2-34.



sh217e

**Figure 2-34. BITG Power Level Adjustment Setup**



sh218e

**Figure 2-35. BITG Power Level Adjustment Locations**

9. On the analyzer, press **SRC PWR ON OFF** (ON), 0, **dBm**, **SGL SWP**.

Note that some analyzers may have sealing compound over A3A15R13 (-10 dB ADJ) and A3A15R18 (0 dB ADJ) adjustments. Remove this compound before making these adjustments.

### 23. BITG Power Level for Option 010

10. Adjust  $-10$  dB ADJ (A3A15R13) for a  $0$  dBm  $\pm 0.05$  dB reading on the measuring receiver. Refer to Figure 2-35 for adjustment location.
11. Set the SRC PWR level to  $-10$  dBm. Note the power displayed on the measuring receiver.  
If the power level is  $-9.77$  dBm to  $-10.23$  dBm, then the adjustment is complete. If the power level is not within the range, then continue with step 12.

Power at  $-10$  dBm Setting \_\_\_\_\_ dBm

12. If the power level noted in step 10 was outside the range of  $-10$  dBm  $\pm 0.23$  dB, perform the following:
  - With the SRC PWR level set to  $-10$  dBm, adjust  $-10$  dB ADJ (A3A15R13) for a  $-10$  dBm  $\pm 0.1$  dB reading on the measuring receiver. Refer to Figure 2-35 for adjustment location.
  - Set the SRC PWR level to  $0$  dBm. Adjust  $0$  dB ADJ (A3A15R18) for a  $0$  dBm  $\pm 0.2$  dB reading on the measuring receiver. Refer to Figure 2-35 for adjustment location.
  - Repeat this step until the output power level is within the tolerances indicated at both the  $-10$  dBm and  $0$  dBm SRC PWR level settings. Adjust  $-10$  dB ADJ only with the SRC POWER level set to  $-10$  dBm, and adjust  $0$  dB ADJ only with the SRC PWR level set to  $0$  dBm.

---

## 24. Tracking Oscillator for Option 010

**This adjustment applies to:**

- HP 8593E spectrum analyzers, Option 010
- HP 8594E spectrum analyzers, Option 010
- HP 8595E spectrum analyzers, Option 010
- HP 8596E spectrum analyzers, Option 010

This is *not* a routine adjustment. This adjustment should only be performed if the range of either the automatic tracking peak adjustment (**TRACKING PEAK**) or the manual tracking peak adjustment (**MAN TRK ADJUST**) is insufficient to peak a signal.

The centering of the tracking oscillator range is adjusted in the factory to ensure that the tracking adjustment will work properly. Over a period of 5 years, however, the center frequency of the tracking oscillator range may drift outside of acceptable limits.

The tracking oscillator range is checked first. A tracking peak test is performed and the output frequency is recorded. Then the manual tracking adjustment is set to its minimum and maximum values and the output frequency is recorded. The minimum and maximum frequencies are compared to the peaked frequency. If the difference is less than 5 kHz, adjustment is necessary.

The adjustment recenters the tracking oscillator range. The A3 RF assembly is placed in its service position to perform this adjustment. A frequency counter is used to measure the output frequency.

### Equipment Required

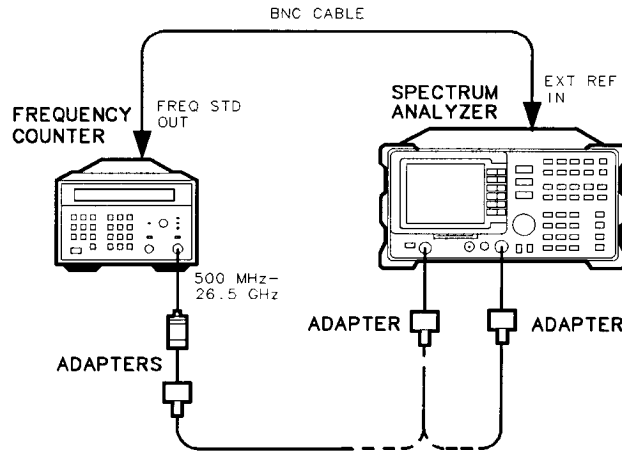
- Microwave frequency counter
- Termination, 50  $\Omega$  termination
- Alignment tool, non-metallic
- Cable, BNC, 122 cm (48 in.) (*two required*)
- Adapter, Type N (f) to APC-3.5 (f)
- Adapter, Type N (m) to BNC (f)

### Additional Equipment for Option 026

- Cable, CAL comb
- Adapter APC-3.5 (f) to APC-3.5 (f)
- Adapter, Type N (f) to APC-3.5 (f)
- Adapter, Type BNC (f) to SMA (m)



## 24. Tracking Oscillator for Option 010



sh219e

Figure 2-36. Frequency Tracking Range Setup

### Procedure

#### Frequency Tracking Range Check

1. Connect a cable between the RF OUT 50  $\Omega$  and INPUT 50  $\Omega$  connectors on the analyzer.
2. Remove the rear-panel jumper that is between the 10 MHz REF OUTPUT and EXT REF IN jacks. Connect the frequency counter FREQ STD OUT connector to the analyzer EXT REF IN connector as shown in Figure 2-36.

3. Press **PRESET** on the analyzer, then set the controls as follows:

CENTER FREQ ..... 500 MHz  
SPAN ..... 0 Hz

4. On the analyzer, press the following key.

**BW** 10 **kHz**  
**AUX CTRL** TRACK GEN SRC PWR ON OFF (ON) 5 **-dBm**

5. On the analyzer press **TRACKING PEAK**. Wait for the PEAKING message to disappear.

6. Set the microwave frequency counter controls as follows:

SAMPLE RATE ..... Midrange  
10 Hz-500 MHz/500 MHz-26.5 GHz SWITCH ..... 500 MHz - 26.5 GHz  
RESOLUTION ..... 1 Hz

7. Connect the RF OUT 50  $\Omega$  connector to the microwave frequency counter input as shown in Figure 2-36.

8. Wait for the microwave frequency counter to gate two or three times, then record the microwave frequency counter reading below as the peaked frequency.

Peaked Frequency: \_\_\_\_\_ MHz

9. On the analyzer, press **MAN TRK ADJUST**, 4095, **ENTER**. Wait for the microwave frequency counter to gate two or three times, then record the microwave frequency counter reading below as the minimum frequency.

Minimum Frequency: \_\_\_\_\_ MHz

## 24. Tracking Oscillator for Option 010

- On the analyzer, press **MAN TRK ADJUST**, 0, **(ENTER)**. Wait for the microwave frequency counter to gate two or three times, then record the microwave frequency counter reading below as the maximum frequency.

Maximum Frequency: \_\_\_\_\_ MHz

- If the absolute value of the difference between either the minimum or maximum frequency and the peaked frequency is less than 5 kHz, proceed with the adjustment procedure below. If the differences are greater than 5 kHz, no adjustment is necessary.
- Disconnect the cable from the EXT REF IN connector, then replace the rear-panel jumper.

### Adjust the Tracking Oscillator

- Remove the A3 RF Section assembly as described in Chapter 9 of this manual. With A3 sitting on top of the A2 display assembly, reconnect all cables from A3 to their respective jacks on A7, A9, A25, and A10. Reconnect W40 to A3A15J8. Connect the 50  $\Omega$  termination to the end of W42.
- Connect the equipment as shown in Figure 2-37. The microwave frequency counter provides the frequency reference for the analyzer.

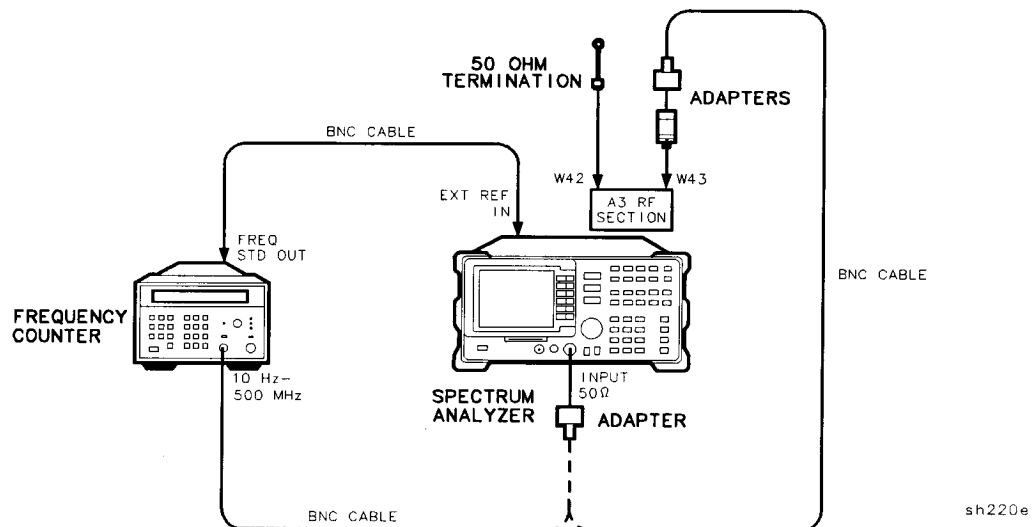


Figure 2-37. Tracking Oscillator Adjustment Setup

- Set the analyzer **(LINE)** switch to on. Press **(AUX CTRL)**, **TRACK GEN**, **SRC PWR ON OFF (ON)**. Allow the analyzer to warm up for at least 5 minutes. Set the controls as follows:

CENTER FREQ ..... 300 MHz  
SPAN ..... 0 Hz

- Set the microwave frequency counter controls as follows:

SAMPLE RATE ..... Fully CCW  
10 Hz-500 MHz/500 MHz-26.5 GHz SWITCH ..... 10 Hz-500 MHz  
50  $\Omega$  - 1 M $\Omega$  SWITCH ..... 50  $\Omega$

- Remove the screw, located on the front of the tracking generator, used to seal the tracking oscillator adjustment.
- On the analyzer, press **(AUX CTRL)**, **TRACK GEN**, **MAN TRK ADJUST**, 0, **(Hz)**.

## 24. Tracking Oscillator for Option 010

19. Record the microwave frequency counter reading in Table 2-16 as F1.
20. On the analyzer, press **MAN TRK ADJUST**, 4095, **(Hz)**.
21. Record the microwave frequency counter reading in Table 2-16 as F2.
22. Calculate Fcenter as shown below, and record it in Table 2-16.

$$F_{center} = (F1 + F2)/2$$

23. Set SRC TRACK ADJ to 350. This sets the tracking oscillator near the center of its frequency range. (The relationship between the SRC TRACK ADJ DAC number and the output frequency is nonlinear.) Adjust SRC TRACK ADJ until the microwave frequency counter reads Fcenter ±100 Hz.
24. Record the value of SRC TRACK ADJ in Table 2-16.

---

**Caution**      A3A15C3 (TRK OSC CTR) is rated for a maximum of 10 adjustment cycles. Due to this limitation, adjust TRK OSC CTR only when absolutely necessary.

---

25. Adjust A3A15C3 (TRK OSC CTR) until the microwave frequency counter reads 300 MHz ±500 Hz.
26. Repeat steps 17 through 24 at least once more until no further adjustment of A3A15C3 is necessary.
27. Set the analyzer **(LINE)** switch to off, then replace the screw removed in step 17.
28. Reinstall the A3 RF Section assembly into the analyzer.
29. Replace the rear-panel jumper between the 10 MHz REF OUTPUT and EXT REF IN connectors.

**Table 2-16. Tracking Oscillator Range Centering**

N	F1 (MHz)	F2 (MHz)	Fcenter (MHz)	SRC TRACK ADJ Setting
1				
2				
3				
4				
5				
6				

## 25. Checking the Absolute Amplitude Accuracy for Option 050

This adjustment applies to:

All HP 8590 E-Series spectrum analyzers, Option 050

To measure the absolute amplitude accuracy of the analyzer, a signal from a synthesized sweeper is output to both the analyzer and a measurement receiver. To determine the absolute amplitude accuracy:

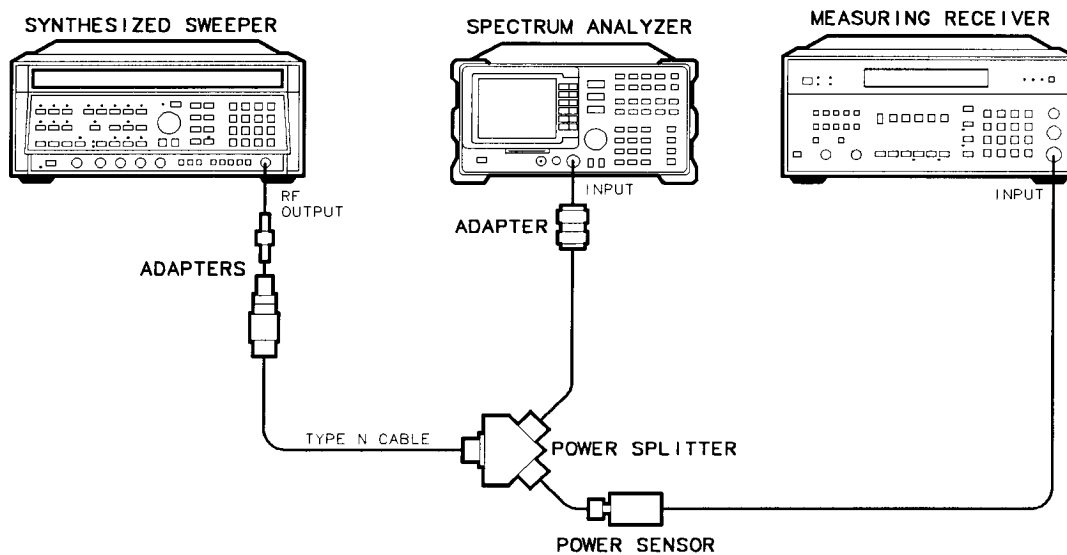
1. The amplitude of the sweeper's signal is adjusted until the analyzer marker reads out a known amplitude.
2. The amplitude of the sweeper's signal is measured by the measuring receiver. (The measurement receiver is used as a power meter.)
3. The difference between the marker readout and the measuring receiver's measurement is determined. This difference is the absolute amplitude accuracy.

### Equipment required

Synthesized sweeper  
Measurement receiver  
Power splitter  
Power sensor, 818 MHz to 948 MHz  
Adapter, Type N (f) to APC 3.5 (m)  
Adapter, APC 3.5 (f) to APC 3.5 (f)  
Adapter, Type N (m) to Type N (m)  
Cable, Type N, 183 cm (72 in)

### Additional Equipment for 026

Adapter, type N (f) to APC-3.5 (f)



sh267e

Figure 2-38. Absolute Amplitude Accuracy Verification

## 25. Checking the Absolute Amplitude Accuracy for Option 050

### Procedure

1. Zero and calibrate the measuring receiver and power sensor in log mode as described in the measuring receiver operation manual.

Note that the absolute amplitude accuracy test should only be performed if the ambient temperature is between 20 °C and 30 °C.

2. Connect the equipment as shown in Figure 2-38. Connect the power splitter to the analyzer using an adapter.
3. Press instrument preset on the synthesized sweeper, then set the controls as follows:

CW ..... 818 MHz  
POWER LEVEL ..... -2 dBm

4. Press **PRESET** on the analyzer and wait for the preset to finish, then press the following analyzer keys.

**FREQUENCY** 818 **MHz**  
**SPAN** 400 **kHz**  
**BW** 100 **kHz**  
VID BW AUTO MAN 30 **kHz**  
**AMPLITUDE** 4 **-dBm**  
ATTEN AUTO MAN 10 **dB**  
**PEAK SEARCH**

### Log Fidelity

5. Set the power sensor cal factor for 818 MHz on the measuring receiver.
6. On the synthesized sweeper, press POWER LEVEL and adjust the output amplitude so that the analyzer marker amplitude reads -9 dBm ±0.05 dB.
7. Record the measuring receiver power reading in Table 2-17.
8. Adjust the output amplitude of the sweeper for analyzer marker amplitude readings of -14 dBm and -19 dBm.
9. Record the measuring receiver power readings in Table 2-17. The readings should be within the limits shown.

**Table 2-17. Log Fidelity**

Analyzer Marker Reading (dBm)	Measuring Receiver		
	Min (dBm)	Reading (dBm)	Max (dBm)
-9	-9.7	_____	-8.3
-14	-14.7	_____	-13.3
-19	-19.7	_____	-21.3

## 25. Checking the Absolute Amplitude Accuracy for Option 050

### Frequency Response Input Attenuator 10 dB

10. Set the frequency of the analyzer to the first measurement frequency shown in Table 2-18.
11. On the synthesized sweeper, press CW and set the frequency to the same measurement frequency as the analyzer is set in the previous step.
12. On the analyzer, press **PEAK SEARCH**.
13. On the synthesized sweeper, press **POWER LEVEL** and adjust the output amplitude so the analyzer marker amplitude reads  $-9 \text{ dBm} \pm 0.05 \text{ dB}$ .
14. Set the power sensor cal factor (for frequency being measured) on the measuring receiver, then record the measuring receiver power reading in Table 2-18.
15. Repeat steps 10 through 14 for frequencies of 836 MHz, 881 MHz, and 948 MHz. Record the results in Table 2-18. The results should be within the limits shown.

**Table 2-18. Frequency Response Attenuator 10 dB**

Synthesized Sweeper Frequency (MHz)	Measuring Receiver		
	Min (dBm)	Reading (dBm)	Max (dBm)
818	-9.7		-8.3
836	-9.7		-8.3
881	-9.7		-8.3
948	-9.7		-8.3

### Frequency Response Input Attenuator 20 dB

16. On the analyzer, press the following keys.  
**AMPLITUDE** **ATTEN AUTO MAN** 20 dB  
**AMPLITUDE** 6 **+dBm**
17. Set the **FREQUENCY** of the analyzer to the measurement frequency shown in Table 2-19.
18. On the synthesized sweeper, press CW and set the frequency to the same measurement frequency as the analyzer is set in the previous step.
19. On the analyzer, press **PEAK SEARCH**.
20. On the sweeper, press **POWER LEVEL** and adjust the amplitude so the analyzer marker amplitude reads  $+1 \text{ dBm} \pm 0.05 \text{ dB}$ .
21. Set the power sensor cal factor (for frequency being measured) on the measuring receiver, then record the measuring receiver power reading in Table 2-19.
22. Repeat steps 17 through 21 for frequencies of 881 MHz, 836 MHz, and 818 MHz. Record the results in Table 2-19. The results should be within the limits shown.

## 25. Checking the Absolute Amplitude Accuracy for Option 050

**Table 2-19. Frequency Response Attenuator 20 dB**

Synthesized Sweeper Frequency (MHz)	Measuring Receiver		
	Min (dBm)	Reading (dBm)	Max (dBm)
948	+ 0.3	_____	+ 1.7
881	+ 0.3	_____	+ 1.7
836	+ 0.3	_____	+ 1.7
818	+ 0.3	_____	+ 1.7

### Frequency Response Input Attenuator 30 dB

23. On the analyzer, press the following keys.

(AMPLITUDE) ATTEN AUTO MAN 30 dB

(AMPLITUDE) 10 (+dBm)

24. Set the FREQUENCY of the analyzer to the measurement frequency shown in Table 2-20.

25. On the analyzer, press (PEAK SEARCH).

26. On the synthesized sweeper, press CW and set the frequency to the same measurement frequency as the analyzer is set in the previous step.

27. On the synthesized sweeper, press POWER LEVEL and adjust the amplitude so the analyzer marker amplitude reads +5 dBm  $\pm$ 0.05 dB.

28. Set the power sensor cal factor (for frequency being measured) on the measuring receiver, then record the measuring receiver power reading in Table 2-20.

29. Repeat steps 24 through 28 for frequencies of 836 MHz, 881 MHz, and 948 MHz. Record the results in Table 2-20.

**Table 2-20. Frequency Response Attenuator 30 dB**

Synthesized Sweeper Frequency (MHz)	Measuring Receiver		
	Min (dBm)	Reading (dBm)	Max (dBm)
818	+ 4.3	_____	+ 5.7
836	+ 4.3	_____	+ 5.7
881	+ 4.3	_____	+ 5.7
948	+ 4.3	_____	+ 5.7

## 25. Checking the Absolute Amplitude Accuracy for Option 050

### Frequency Response Input Attenuator 40 dB

30. On the analyzer, press the following keys.

**AMPLITUDE** ATTEN AUTO MAN 40 dB

**AMPLITUDE** 10 **+dBm**

31. Set the FREQUENCY of the analyzer to the measurement frequency shown in Table 2-21.
32. On the synthesized sweeper, press CW, then set the frequency to the same measurement frequency as the analyzer is set in the previous step.
33. On the analyzer, press **PEAK SEARCH**.
34. On the synthesized sweeper, press POWER LEVEL and adjust the amplitude so the analyzer marker amplitude reads +5 dBm  $\pm 0.05$  dB.
35. Set the power sensor cal factor (for frequency being measured) on the measuring receiver, then record the measuring receiver power reading in Table 2-21.
36. Repeat steps 31 through 35 for frequencies of 881 MHz, 836 MHz, and 818 MHz. Record the results in Table 2-21.

**Table 2-21. Frequency Response Attenuator 40 dB**

Synthesized Sweeper Frequency (MHz)	Measuring Receiver		
	Min (dBm)	Reading (dBm)	Max (dBm)
948	+ 4.0	_____	+ 6.0
881	+ 4.0	_____	+ 6.0
836	+ 4.0	_____	+ 6.0
818	+ 4.0	_____	+ 6.0



---

## 26. Correcting for Absolute Amplitude Accuracy for Option 050

### This adjustment applies to:

All HP 8590 E-Series spectrum analyzers, Option 050

The frequency response of the analyzer is adjusted to optimize the amplitude accuracy for the frequency range between 818 MHz and 948 MHz. The amplitude error from “Checking the Absolute Amplitude Accuracy for Option 050” is used to determine how much flatness correction is necessary. Normally, only a small amount of adjustment is needed to bring the absolute amplitude accuracy of HP 8590 E-Series spectrum analyzer equipped with an Option 050 into specification.

1. Looking at Table 2-18, Frequency Response Attenuator 10 dB, calculate the error from the nominal value of  $-9$  dB. For example, if the measuring receiver reading at 818 MHz is  $-9.2$  dB, then the error is  $-0.2$  dB. Find the average error by adding the four errors for each frequency and then dividing the sum by four.

Average Error \_\_\_\_\_ dB

Note that if the average error is greater than 0.5 dB, there may be a hardware problem. Typically, front-end component problems are responsible for large amplitude errors. A defective First Mixer or a poor cable connection may cause a power hole near the analyzer Option 050 frequency band. In this case, performing a frequency response check will uncover this type of problem. Perform a functional check of the input attenuator if the errors for some attenuation settings are larger than others.

---

**Caution**      The next step disables the protection for the factory correction constants.

---

2. Press the following analyzer keys.

```

FREQUENCY -2001 Hz
CAL More 1 of 4 More 2 of 4
Service Cal
Flatness Data
EDIT FLATNESS

```

3. Press  $\uparrow$  (step up key) until the ERROR readout for 804 MHz is displayed (*781 MHz for an HP 8591E spectrum analyzer or an HP 8591C cable TV analyzer*).
4. Read the amplitude error from the display and record it in Table 2-22 for the HP 8593E, HP 8594E, HP 8595E, and HP 8596E spectrum analyzers. Use Table 2-23 for HP 8591E spectrum analyzers or HP 8591C cable TV analyzers.

## 26. Correcting for Absolute Amplitude Accuracy for Option 050

**Table 2-22.**  
**Frequency Response Errors: HP 8593E, 8594E, 8595E, 8596E**

Frequency	Amplitude ERROR	Corrected Flatness ERROR
804 MHz		
876 MHz		
948 MHz		
1.02 GHz		

**Table 2-23. Frequency Response Errors: HP 8591C and HP 8591E**

Frequency	Amplitude ERROR	Corrected Flatness ERROR
781 MHz		
818 MHz		
855 MHz		
892 MHz		

Repeat steps 3 and 4 for the next frequency indicated in Table 2-22 or Table 2-23 until all four points have been recorded.

- Subtract the Average Error, calculated in step 1, from each Amplitude ERROR from Table 2-22 or Table 2-23, then record column 3 as the Corrected Flatness ERROR.

Do not subtract more than 0.5 dB from the Amplitude ERROR. If the Average Error is more than 0.5 dB, it may not be possible to make corrections during the adjustment.

- Using  $\Downarrow$  (step down key), set the frequency displayed on the analyzer to 804 MHz (*781 MHz for HP 8591E spectrum analyzers or HP 8591C cable TV analyzers*).
- Enter the Corrected Flatness ERROR from Table 2-22 or Table 2-23 for the frequency displayed using the DATA keys. Terminate the entry with the  $\boxed{+dBm}$ .

After the new data is entered, the analyzer will automatically jump to the next frequency correction point. Enter the next Corrected Flatness ERROR from the table.

To confirm the entries, press  $\Downarrow$  (step down key) to the frequency of interest. Re-check the displayed error against the Corrected Flatness ERROR from column 3.

- Perform the frequency response verification test from the calibration guide for your instrument. Only checking Band 0 is necessary.

## 27. Checking the Absolute Amplitude Accuracy for Option 051

This adjustment applies to:

All HP 8590 E-Series spectrum analyzers, Option 051

To measure the absolute amplitude accuracy of the analyzer in the frequency ranges 810 MHz to 956 MHz and 1429 MHz to 1501 MHz, a signal from a synthesized sweeper is output to both the analyzer and a measurement receiver. To determine the absolute amplitude accuracy:

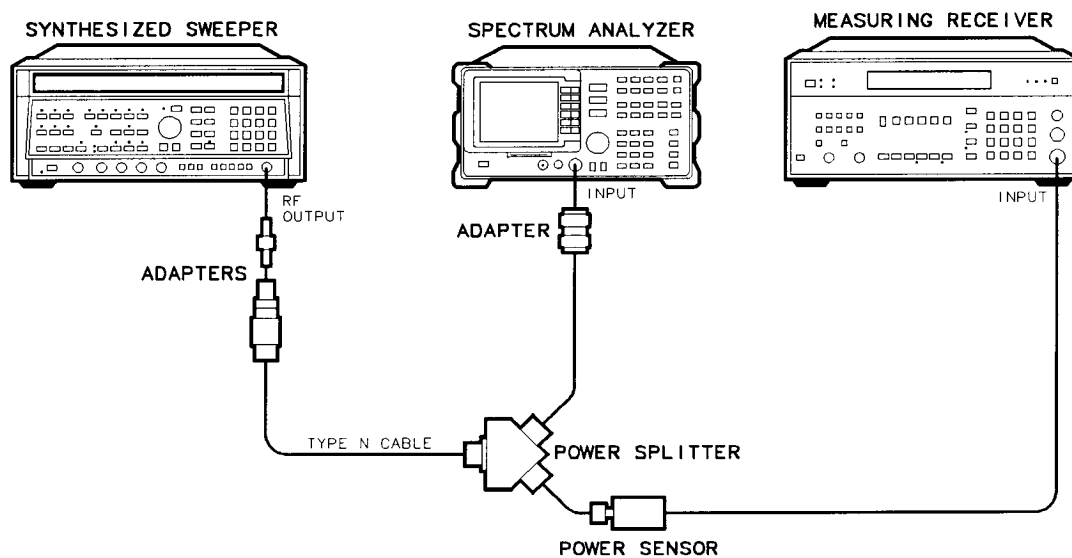
1. The amplitude of the sweeper's signal is adjusted until the analyzer marker reads out a known amplitude.
2. The amplitude of the sweeper's signal is measured by the measuring receiver. (The measurement receiver is used as a power meter.)
3. The difference between the marker readout and the measuring receiver's measurement is determined. This difference is the absolute amplitude accuracy.

### Equipment required

Synthesized sweeper  
Measurement receiver  
Power splitter  
Power sensor, 810 MHz to 1501 MHz  
Adapter, Type N (f) to APC 3.5 (m)  
Adapter, APC 3.5 (f) to APC 3.5 (f)  
Adapter, Type N (m) to Type N (m)  
Cable, Type N, 183 cm (72 in)

### Additional Equipment for Option 026

Adapter, Type N (f) to APC-3.5 (f)



sh267e

Figure 2-39. Absolute Amplitude Accuracy Verification

## 27. Checking the Absolute Amplitude Accuracy for Option 051

### Procedure

1. Zero and calibrate the measuring receiver and power sensor in log mode as described in the measuring receiver operation manual.

Note that the absolute amplitude accuracy test should only be performed if the ambient temperature is between 20 °C and 30 °C.

2. Connect the equipment as shown in Figure 2-39. Connect the power splitter to the analyzer using an adapter.
3. Press instrument preset on the synthesized sweeper, then set the controls as follows:

CW ..... 810 MHz  
 POWER LEVEL ..... -2 dBm

4. Press **PRESET** on the analyzer and wait for the preset to finish, then press the following analyzer keys.

**FREQUENCY** 810 **MHz**  
**SPAN** 400 **kHz**  
**BW** 100 **kHz**  
 VID BW AUTO MAN 30 **kHz**  
**AMPLITUDE** 4 **-dBm**  
 ATTEN AUTO MAN 10 **dB**  
**PEAK SEARCH**

### Log Fidelity

5. Set the power sensor cal factor for 810 MHz on the measuring receiver.
6. On the synthesized sweeper, press POWER LEVEL and adjust the output amplitude so that the analyzer marker amplitude reads -9 dBm ±0.05 dB.
7. Record the measuring receiver power reading in Table 2-24.
8. Adjust the output amplitude of the sweeper for analyzer marker amplitude readings of -14 dBm and -19 dBm.
9. Record the measuring receiver power readings in Table 2-24. The readings should be within the limits shown.

**Table 2-24. Log Fidelity**

Analyzer Marker Reading (dBm)	Measuring Receiver		
	Min (dBm)	Reading (dBm)	Max (dBm)
-9	-9.7	_____	-8.3
-14	-14.7	_____	-13.3
-19	-19.7	_____	-21.3

27. Checking the Absolute Amplitude Accuracy for Option 051

**Frequency Range 810 MHz to 956 MHz**

**Frequency Response Input Attenuator 10 dB**

10. Set the frequency of the analyzer to the first measurement frequency shown in Table 2-25.
11. On the synthesized sweeper, press CW and set the frequency to the same measurement frequency as the analyzer is set in the previous step.
12. On the analyzer, press **PEAK SEARCH**.
13. On the synthesized sweeper, press **POWER LEVEL** and adjust the output amplitude so the analyzer marker amplitude reads  $-9 \text{ dBm} \pm 0.05 \text{ dB}$ .
14. Set the power sensor cal factor (for frequency being measured) on the measuring receiver, then record the measuring receiver power reading in Table 2-25.
15. Repeat steps 10 through 14 for frequencies of 826 MHz, 940 MHz, and 956 MHz. Record the results in Table 2-25. The results should be within the limits shown.

**Table 2-25. Frequency Response Attenuator 10 dB**

Synthesized Sweeper Frequency (MHz)	Measuring Receiver		
	Min (dBm)	Reading (dBm)	Max (dBm)
810	-9.6		-8.4
826	-9.6		-8.4
940	-9.6		-8.4
956	-9.6		-8.4

**Frequency Response Input Attenuator 20 dB**

16. On the analyzer, press the following keys.  
**AMPLITUDE** **ATTEN AUTO MAN 20 dB**  
**AMPLITUDE** **6 +dBm**
17. Set the **FREQUENCY** of the analyzer to the measurement frequency shown in Table 2-26.
18. On the synthesized sweeper, press CW and set the frequency to the same measurement frequency as the analyzer is set in the previous step.
19. On the analyzer, press **PEAK SEARCH**.
20. On the sweeper, press **POWER LEVEL** and adjust the amplitude so the analyzer marker amplitude reads  $+1 \text{ dBm} \pm 0.05 \text{ dB}$ .
21. Set the power sensor cal factor (for frequency being measured) on the measuring receiver, then record the measuring receiver power reading in Table 2-26.
22. Repeat steps 17 through 21 for frequencies of 948 MHz, 826 MHz, and 810 MHz. Record the results in Table 2-26. The results should be within the limits shown.

27. Checking the Absolute Amplitude Accuracy for Option 051

**Table 2-26. Frequency Response Attenuator 20 dB**

Synthesized Sweeper Frequency (MHz)	Measuring Receiver		
	Min (dBm)	Reading (dBm)	Max (dBm)
956	+0.4	_____	+1.6
940	+0.4	_____	+1.6
826	+0.4	_____	+1.6
810	+0.4	_____	+1.6

**Frequency Response Input Attenuator 30 dB**

23. On the analyzer, press the following keys.

**AMPLITUDE** **ATTEN AUTO MAN** 30 dB

**AMPLITUDE** 10 **+dBm**

24. Set the FREQUENCY of the analyzer to the measurement frequency shown in Table 2-27.

25. On the analyzer, press **PEAK SEARCH**.

26. On the synthesized sweeper, press CW and set the frequency to the same measurement frequency as the analyzer is set in the previous step.

27. On the synthesized sweeper, press POWER LEVEL and adjust the amplitude so the analyzer marker amplitude reads +5 dBm ±0.05 dB.

28. Set the power sensor cal factor (for frequency being measured) on the measuring receiver, then record the measuring receiver power reading in Table 2-27.

29. Repeat steps 24 through 28 for frequencies of 826 MHz, 940 MHz, and 956 MHz. Record the results in Table 2-27.

**Table 2-27. Frequency Response Attenuator 30 dB**

Synthesized Sweeper Frequency (MHz)	Measuring Receiver		
	Min (dBm)	Reading (dBm)	Max (dBm)
810	+4.4	_____	+5.6
826	+4.4	_____	+5.6
940	+4.4	_____	+5.6
956	+4.4	_____	+5.6

## 27. Checking the Absolute Amplitude Accuracy for Option 051

### Frequency Response Input Attenuator 40 dB

30. On the analyzer, press the following keys.

**AMPLITUDE** **ATTEN AUTO MAN** 40 dB

**AMPLITUDE** 10 **+dBm**

31. Set the FREQUENCY of the analyzer to the measurement frequency shown in Table 2-28.

32. On the synthesized sweeper, press CW, then set the frequency to the same measurement frequency as the analyzer is set in the previous step.

33. On the analyzer, press **PEAK SEARCH**.

34. On the synthesized sweeper, press POWER LEVEL and adjust the amplitude so the analyzer marker amplitude reads +5 dBm  $\pm 0.05$  dB.

35. Set the power sensor cal factor (for frequency being measured) on the measuring receiver, then record the measuring receiver power reading in Table 2-28.

36. Repeat steps 31 through 35 for frequencies of 940 MHz, 826 MHz, and 810 MHz. Record the results in Table 2-28.

**Table 2-28. Frequency Response Attenuator 40 dB**

Synthesized Sweeper Frequency (MHz)	Measuring Receiver		
	Min (dBm)	Reading (dBm)	Max (dBm)
956	+ 4.0	_____	+ 6.0
940	+ 4.0	_____	+ 6.0
826	+ 4.0	_____	+ 6.0
810	+ 4.0	_____	+ 6.0

## 27. Checking the Absolute Amplitude Accuracy for Option 051

### Frequency Range 1429 MHz to 1501 MHz

#### Frequency Response Input Attenuator 10 dB

37. Set the frequency of the analyzer to the first measurement frequency shown in Table 2-29.
38. On the synthesized sweeper, press CW and set the frequency to the same measurement frequency as the analyzer is set in the previous step.
39. On the analyzer, press **PEAK SEARCH**.
40. On the synthesized sweeper, press **POWER LEVEL** and adjust the output amplitude so the analyzer marker amplitude reads  $-9 \text{ dBm} \pm 0.05 \text{ dB}$ .
41. Set the power sensor cal factor (for frequency being measured) on the measuring receiver, then record the measuring receiver power reading in Table 2-29.
42. Repeat steps 37 through 41 for frequencies of 1453 MHz, 1477 MHz, and 1501 MHz. Record the results in Table 2-29. The results should be within the limits shown.

**Table 2-29. Frequency Response Attenuator 10 dB**

Synthesized Sweeper Frequency (MHz)	Measuring Receiver		
	Min (dBm)	Reading (dBm)	Max (dBm)
1429	-9.6		-8.4
1453	-9.6		-8.4
1477	-9.6		-8.4
1501	-9.6		-8.4

#### Frequency Response Input Attenuator 20 dB

43. On the analyzer, press the following keys.  
**AMPLITUDE** **ATTEN** **AUTO** **MAN** 20 dB  
**AMPLITUDE** 6 (+dBm)
44. Set the **FREQUENCY** of the analyzer to the measurement frequency shown in Table 2-30.
45. On the synthesized sweeper, press CW and set the frequency to the same measurement frequency as the analyzer is set in the previous step.
46. On the analyzer, press **PEAK SEARCH**.
47. On the sweeper, press **POWER LEVEL** and adjust the amplitude so the analyzer marker amplitude reads  $+1 \text{ dBm} \pm 0.05 \text{ dB}$ .
48. Set the power sensor cal factor (for frequency being measured) on the measuring receiver, then record the measuring receiver power reading in Table 2-30.
49. Repeat steps 44 through 48 for frequencies of 1477 MHz, 1453 MHz, and 1428 MHz. Record the results in Table 2-30. The results should be within the limits shown.



## 27. Checking the Absolute Amplitude Accuracy for Option 051

**Table 2-30. Frequency Response Attenuator 20 dB**

Synthesized Sweeper Frequency (MHz)	Measuring Receiver		
	Min (dBm)	Reading (dBm)	Max (dBm)
1501	+0.4	_____	+1.6
1477	+0.4	_____	+1.6
1453	+0.4	_____	+1.6
1429	+0.4	_____	+1.6

### Frequency Response Input Attenuator 30 dB

50. On the analyzer, press the following keys.

AMPLITUDE ATTEN AUTO MAN 30 dB

AMPLITUDE 10 +dBm

51. Set the FREQUENCY of the analyzer to the measurement frequency shown in Table 2-31.

52. On the analyzer, press PEAK SEARCH.

53. On the synthesized sweeper, press CW and set the frequency to the same measurement frequency as the analyzer is set in the previous step.

54. On the synthesized sweeper, press POWER LEVEL and adjust the amplitude so the analyzer marker amplitude reads +5 dBm  $\pm$ 0.05 dB.

55. Set the power sensor cal factor (for frequency being measured) on the measuring receiver, then record the measuring receiver power reading in Table 2-31.

56. Repeat steps 51 through 55 for frequencies of 1453 MHz, 1477 MHz, and 1501 MHz. Record the results in Table 2-31.

**Table 2-31. Frequency Response Attenuator 30 dB**

Synthesized Sweeper Frequency (MHz)	Measuring Receiver		
	Min (dBm)	Reading (dBm)	Max (dBm)
1429	+4.4	_____	+5.6
1453	+4.4	_____	+5.6
1477	+4.4	_____	+5.6
1501	+4.4	_____	+5.6

## 27. Checking the Absolute Amplitude Accuracy for Option 051

### Frequency Response Input Attenuator 40 dB

57. On the analyzer, press the following keys.

**AMPLITUDE** ATTEN AUTO MAN 40 dB

**AMPLITUDE** 10 **+dBm**

58. Set the FREQUENCY of the analyzer to the measurement frequency shown in Table 2-32.

59. On the synthesized sweeper, press CW, then set the frequency to the same measurement frequency as the analyzer is set in the previous step.

60. On the analyzer, press **PEAK SEARCH**.

61. On the synthesized sweeper, press POWER LEVEL and adjust the amplitude so the analyzer marker amplitude reads +5 dBm  $\pm 0.05$  dB.

62. Set the power sensor cal factor (for frequency being measured) on the measuring receiver, then record the measuring receiver power reading in Table 2-32.

63. Repeat steps 58 through 62 for frequencies of 1477 MHz, 1453 MHz, and 1429 MHz. Record the results in Table 2-32.

**Table 2-32. Frequency Response Attenuator 40 dB**

Synthesized Sweeper Frequency (MHz)	Measuring Receiver		
	Min (dBm)	Reading (dBm)	Max (dBm)
1501	+4.0	_____	+6.0
1477	+4.0	_____	+6.0
1453	+4.0	_____	+6.0
1429	+4.0	_____	+6.0

---

## 28. Correcting for Absolute Amplitude Accuracy for Option 051

### This adjustment applies to:

All HP 8590 E-Series spectrum analyzers, Option 051

The frequency response of the analyzer is adjusted to optimize the amplitude accuracy for the frequency range 810 MHz to 956 MHz and 1429 MHz to 1501 MHz. The amplitude error from “Checking the Absolute Amplitude Accuracy for Option 051” is used to determine how much flatness correction is necessary. Normally, only a small amount of adjustment is needed to bring the absolute amplitude accuracy of HP 8590 E-Series spectrum analyzer equipped with an Option 051 into specification.

### Frequency Range 810 MHz to 956 MHz

1. Looking at Table 2-25, Frequency Response Attenuator 10 dB, calculate the error from the nominal value of  $-9$  dB for each frequency. For example, if the measuring receiver reading at 810 MHz is  $-9.2$  dB, then the error is  $-0.2$  dB. Find the average error by adding the four errors for each frequency and then dividing the sum by four.

Average Error \_\_\_\_\_ dB

Note that if the average error is greater than 0.5 dB, there may be a hardware problem. Typically, front-end component problems are responsible for large amplitude errors. A defective First Mixer or a poor cable connection may cause a power hole near the analyzer Option 051 frequency band. In this case, performing a frequency response check will uncover this type of problem. Perform a functional check of the input attenuator if the errors for some attenuation settings are larger than others.

---

**Caution**      The next step disables the protection for the factory correction constants.

---

2. Press the following analyzer keys.

```
FREQUENCY -2001 Hz
CAL More 1 of 4 More 2 of 4
Service Cal
Flatness Data
EDIT FLATNESS
```

3. Press  $\uparrow$  (step up key) until the ERROR readout for 804 MHz is displayed (*781 MHz for an HP 8591E spectrum analyzer or an HP 8591C cable TV analyzer*).
4. Read the amplitude error from the display and record it in Table 2-33 for the HP 8593E, HP 8594E, HP 8595E, and HP 8596E spectrum analyzers. Use Table 2-34 for HP 8591E spectrum analyzers or HP 8591C cable TV analyzers.

## 28. Correcting for Absolute Amplitude Accuracy for Option 051

**Table 2-33.**  
**Frequency Response Errors: HP 8593E, 8594E, 8595E, 8596E**

Frequency	Amplitude ERROR	Corrected Flatness ERROR
804 MHz		
876 MHz		
948 MHz		
1.02 GHz		

**Table 2-34. Frequency Response Errors: HP 8591C and HP 8591E**

Frequency	Amplitude ERROR	Corrected Flatness ERROR
781 MHz		
818 MHz		
855 MHz		
892 MHz		

Repeat steps 3 and 4 for the next frequency indicated in Table 2-33 or Table 2-34 until all four points have been recorded.

5. Subtract the Average Error, calculated in step 1, from each Amplitude ERROR from Table 2-33 or Table 2-34, then record column 3 as the Corrected Flatness ERROR.

Do not subtract more than 0.5 dB from the Amplitude ERROR. If the Average Error is more than 0.5 dB, it may not be possible to make corrections during the adjustment.

6. Using  $\downarrow$  (step down key), set the frequency displayed on the analyzer to 804 MHz (*781 MHz for HP 8591E spectrum analyzers or HP 8591C cable TV analyzers*).
7. Enter the Corrected Flatness ERROR from Table 2-33 or Table 2-34 for the frequency displayed using the DATA keys. Terminate the entry with the  $\boxed{+dBm}$ .

After the new data is entered, the analyzer will automatically jump to the next frequency correction point. Enter the next Corrected Flatness ERROR from the table.

To confirm the entries, press  $\downarrow$  (step down key) to the frequency of interest. Re-check the displayed error against the Corrected Flatness ERROR from column 3.

8. Press **More**, **EXIT** after all corrections are complete.

## 28. Correcting for Absolute Amplitude Accuracy for Option 051

### Frequency Range 1429 MHz to 1501 MHz

9. Looking at Table 2-29, Frequency Response Attenuator 10 dB, calculate the error from the nominal value of  $-9$  dB for each frequency. For example, if the measuring receiver reading at 1429 MHz is  $-9.2$  dB, then the error is  $-0.2$  dB. Find the average error by adding the four errors for each frequency and then dividing the sum by four.

Average Error \_\_\_\_\_ dB

---

**Caution** The next step disables the protection for the factory correction constants.

---

10. Press the following analyzer keys.

```

(PRESET) (wait for completion)
(FREQUENCY) -2001 (Hz)
CAL More 1 of 4 More 2 of 4
Service Cal
Flatness Data
EDIT FLATNESS
    
```

11. Press  $\uparrow$  (step up key) until the ERROR readout for 1.380 GHz is displayed (*1.410 GHz for an HP 8591E spectrum analyzer or an HP 8591C cable TV analyzer*).
12. Read the amplitude error from the display and record it in Table 2-35 for the HP 8593E, HP 8594E, HP 8595E, and HP 8596E spectrum analyzers. Use Table 2-36 for HP 8591E spectrum analyzers or HP 8591C cable TV analyzers.

**Table 2-35.**  
**Frequency Response Errors: HP 8593E, 8594E, 8595E, 8596E**

Frequency	Amplitude ERROR	Corrected Flatness ERROR
1.380 GHz		
1.452 GHz		
1.524 GHz		
1.596 GHz		

**Table 2-36. Frequency Response Errors: HP 8591C and HP 8591E**

Frequency	Amplitude ERROR	Corrected Flatness ERROR
1.410 GHz		
1.447 GHz		
1.484 GHz		
1.521 GHz		

## 28. Correcting for Absolute Amplitude Accuracy for Option 051

Repeat steps 10 and 11 for the next frequency indicated in Table 2-35 or Table 2-36 until all four points have been recorded.

13. Subtract the Average Error, calculated in step 9, from each Amplitude ERROR from Table 2-35 or Table 2-36, then record column 3 as the Corrected Flatness ERROR.

Do not subtract more than 0.5 dB from the Amplitude ERROR. If the Average Error is more than 0.5 dB, it may not be possible to make corrections during the adjustment.

14. Using  $\downarrow$  (step down key), set the frequency displayed on the analyzer to 1.380 GHz (*1.410 GHz for HP 8591E spectrum analyzers or HP 8591C cable TV analyzers*).
15. Enter the Corrected Flatness ERROR from Table 2-35 or Table 2-36 for the frequency displayed using the DATA keys. Terminate the entry with the  $\boxed{+dBm}$ .

After the new data is entered, the analyzer will automatically jump to the next frequency correction point. Enter the next Corrected Flatness ERROR from the table.

To confirm the entries, press  $\downarrow$  (step down key) to the frequency of interest. Re-check the displayed error against the Corrected Flatness ERROR from column 3.

16. Press **More**, **EXIT** after all corrections are complete.
17. Perform the frequency response verification test from the calibration guide for your instrument. Only checking Band 0 is necessary.

## Backing Up and Reloading Correction Constants

---

This chapter provides information for safe-guarding the correction data stored in RAM on the processor/video board assembly, and restoring the analyzer memory after a repair or replacement of the processor/video board assembly.

Commands within parenthesis after a softkey, for example (LOG), are used throughout this chapter to indicate the part of a softkey which should be underlined when the key is pressed.

Refer to Chapter 4 for information that is useful when first starting to troubleshoot an analyzer failure.

---

### Before You Start

There are three things you must do *before* you begin troubleshooting an instrument failure.

1. Familiarize yourself with the safety symbols marked on the analyzer, the general safety considerations, and the safety note definitions given in the front of this guide.
2. Read the section entitled “Protection from Electrostatic Discharge” in Chapter 1. The analyzer contains static-sensitive components.
3. Become familiar with the organization of the troubleshooting information in this service guide and the information in this chapter.

---

**Warning**     **The analyzer contains potentially hazardous voltages. Refer to the safety symbols on the analyzer and the general safety considerations in this guide before operating the unit with the cover removed. Failure to heed the safety precautions can result in severe or fatal injury.**

---

---

## Backing Up Analyzer Correction Constants

This section describes how to retrieve the correction-constant data from the instrument memory and record the data as a backup copy. As long as the data remains valid, it can be used to recalibrate the instrument quickly after a memory loss. It is recommended that a copy of this data be maintained in the user's records. Procedures for restoring the correction constants to battery-backed RAM memory are also provided in this section.

Note that if the current correction constants are not valid, new correction constants must be generated. Refer to the following adjustment procedures in Chapter 2 of this service guide.

- Adjusting the 10 MHz Reference.
- Adjusting the Frequency Response (*for your analyzer*).
- Adjusting the Cal Attenuator Error.
- Correcting the External ALC Error Correction (*for Option 010 and 011 only*).

The HP 8590 E-Series and L-Series spectrum analyzer, HP 8591C cable TV analyzer, and HP 8594Q QAM analyzer stores the following correction constants in RAM.

**Flatness-correction constants.** Used to correct frequency-response amplitude errors.

**Step-attenuation correction constants.** Used to correct A12 Amplitude Control step-attenuator errors and provide a relative amplitude reference for the **CAL AMPTD** self-calibration routine.

**Timebase correction constant.** Used by the DAC that tunes the RTX0 (10 MHz timebase) on the A25 Counter Lock assembly.

*Analyzers equipped with the precision frequency reference do not use this correction constant.*

**CALGX slope and offset correction constants.** Used to improve the performance of the external automatic level control (ALC).

*Only analyzers equipped with Option 010 or 011 use these corrections.*

### Retrieve the timebase and flatness-correction constants

1. Make a copy of the Correction Constant Backup-Data Record at the end of this chapter.
2. Record the date and instrument serial number.

Skip steps 3 and 4 if your instrument is equipped with a precision frequency reference or if testing an HP 8590L with Option 713.

3. Press the following keys.

**PRESET**

**FREQUENCY** -37 **Hz**

**CAL** More 1 of 4 More 2 of 4

4. Press **VERIFY TIMEBASE**, then record the number that is displayed in the active-function block in Table 3-1.
5. Press the following keys.

**SERVICE CAL**, **FLATNESS DATA**, **EDIT FLATNESS**



6. The signal trace represents the frequency-response (flatness) correction-constant data. The active-function block displays the frequency response error.
7. Record the frequency-response error in the appropriate table for your analyzer. Table 3-2 is for the HP 8590L and HP 8591E spectrum analyzers and HP 8591C cable TV analyzers. Tables 3-3 through 3-8 are for all other HP 8590 E-Series and L-Series spectrum analyzers.
8. Press  $\uparrow$ , then record the next frequency-response error in the appropriate table.
9. Repeat the previous step until all frequency-response errors are recorded. Use  $\downarrow$  to view previous data points.
10. Press **EXIT** when all frequency-response errors have been recorded.

### Retrieve the A12 step-gain and CALTGX correction constants

1. Press the following keys to view the current A12 step-attenuator correction constants.

**CAL** More 1 of 4 More 2 of 4

**SERVICE DIAG**

**DISPLAY CAL DATA**

2. Look at the first five entries in the CA ATT ERR column; they are the amplitude errors for the 1 dB, 2 dB, 4 dB, 8 dB, and 16 dB step-attenuators.
3. Record the amplitude errors (correction constants) for the five step-attenuators in Table 3-9. Step 4 is for analyzers equipped with Option 010 or 011 only. Skip this step for all other analyzers.
4. Record the CALTGX slope and offset correction constants in Table 3-10. The correction constants are printed on a label that is located on the A7A1 Tracking Generator Control Board assembly.

File the completed copy of the Correction Constant Backup-Data Record for future reference.

---

## Analyzer Initialization

This procedure is used to restore the factory/service correction constants to the processor/video board assembly, and to initialize the analyzer settings after a non-volatile memory loss. The loss of non-volatile memory may be caused by the following conditions.

- Installation of a new A16 Processor/Video board assembly
- Dead B1 battery

### Firmware startup sequence

The firmware installed in the analyzer recognizes when the analyzer non-volatile memory is lost by comparing the contents of two RAM locations with known values. If there is a discrepancy, the startup routine is initiated.

The analyzer startup routine does the following:

- User memory is erased
- DLP editor memory is initialized
- Power-on state is set to PRESET
- Windows are initialized
- Video constants are initialized
- Display units are set to dBm
- Identifies which analyzer is present except for the following analyzers.
  - HP 8591C
  - HP 8590D
  - HP 8595E
  - HP 8592D

If the analyzer is either an HP 8595E or HP 8596E, the screen will prompt you to enter the correct analyzer model number. Enter 5 for an HP 8595E or a 6 for an HP 8596E spectrum analyzer.

After the startup routine is complete, the message USING DEFAULTS <n> is displayed on screen. The value of <n> is a key to what condition caused the startup sequence. This number was used in the development of the firmware and is of no value in troubleshooting.

In the case of an HP 8591C cable TV analyzer, the firmware is unable to identify this model number. After the loss of correction constants, an HP 8591C cable TV analyzer will actually identify as an HP 8591E spectrum analyzer.

If the analyzer is an HP 8591C, the analyzer's startup routine will identify it as an HP 8591E. Use this procedure to change the identity back to an HP 8591C.

Press the following keys.

**PRESET** (wait until preset is complete)

**DISPLAY**, **Change Title**

Use the softkeys to type in the following remote command. Don't forget to include the semicolon (;).

```
FACTSET 11023,1;
```

---

**Note** A remote controller may be used in place of the execute title function.

---

**DISPLAY**, **Hold**

Press the following keys.

**CAL** More 1 of 4 More 2 of 4 Service Cal EXECUTE TITLE

**PRESET** (wait until preset is complete)

**CONFIG** More 1 of 3 SHOW OPTIONS

Confirm that the correct analyzer model number is displayed.

### Set the default configuration

Set the default configuration by pressing the following analyzer keys.

**CONFIG** More 1 of 3 DEFAULT CONFIG DEFAULT CONFIG

### Reset the power-on units

Set the power-on units by pressing the following analyzer keys.

**PRESET**

**FREQUENCY** -2001 **Hz**

**AMPLITUDE** More 1 of 2

**INPUT Z** 50 75 (so that 50 is underlined)

*75  $\Omega$  input only:* Press **INPUT Z** 50 75 , so that 75 is underlined.

**AMPLITUDE** SCALE LOG LIN (LOG) More 1 of 2

Amptd Units dBm

*75  $\Omega$  input only:* Press dBmV .

**AMPLITUDE** SCALE LOG LIN (LIN) More 1 of 2

Amptd Units Volts

**CAL** More 1 of 4 More 2 of 4 Service Cal STOR PWR ON UNITS

---

## Reloading the Correction Constants

This procedure assumes that you have valid correction constant data from a previous backup. Without backup data, new correction constants must be generated by performing the adjustments in Chapter 2.

### Reload the timebase-correction constant

*Skip this step for instruments equipped with a precision frequency reference.*

Reload the timebase correction constant by pressing the following analyzer keys.

```
PRESET
FREQUENCY -2001 Hz
CAL More 1 of 4 More 2 of 4
Service Cal CAL TIMEBASE
```

Type the value from the Table (corr backup) using the DATA Keys, then press **ENTER**.

### Reload the flatness-correction constants

1. Reload the flatness-correction constants by pressing the following analyzer keys.

```
Press FREQUENCY
Enter -2001 Hz
Press CAL More 1 of 4 More 2 of 4
Press Service Cal
Flatness Data
INT FLAT For Option 026: Press INIT FLT 26.5 GHz
EDIT FLATNESS
```

2. Enter each correction constant listed in the Correction Constant Backup-Data Record, then terminate the entry with the **+dBm** or **-dBm** key, as appropriate. Each entry is displayed briefly before the data-entry routine steps to the next correction data point.

Use the **↑** and **↓** keys to edit previously entered correction data.

3. When all flatness-correction constants are entered, press **STORE FLATNESS**, More **EXIT**.

## Reload the A12 step-gain-correction constants

1. Reload the A12 step-gain-correction constants by pressing the following keys.

```
PRESET
FREQUENCY -2001 Hz
CAL More 1 of 4 More 2 of 4
Service Cal SET ATTN ERROR
```

REF LVL OFFSET is displayed in the active-function block above the prompt  
ENTER CAL ATTN ERROR 1.

2. At the prompt, enter the five step-attenuator correction constants (resolution to 0.01 dB) listed in the Correction Constant Backup-Data Record, then terminate each entry with either **+dBm** or **-dBm**, as appropriate. Typically 1 and 2 dB step errors are negative. The 4 and 8 dB steps are positive. The 16 dB step is always 0 dB.

Each entry is displayed to the left of the graticule as an amplitude offset, but only with 0.1 dB resolution. A PRESET occurs after the 16 dB step-attenuator error is entered.

## Reload the differential phase calibration constant

*This step is for instruments equipped with Option 107 only.*

1. Install HP 85721A Cable TV Measurements Personality.

Refer to your cable TV measurements user's guide for the procedure to load this personality.

```
Press FREQUENCY
Enter -2001 Hz
Press CAL More 1 of 4 More 2 of 4
Press Service Cal Flatness Data
Press Store DP CAL
Enter -7373 Hz
```

---

## Instrument Calibration after Reloading the Correction Constants

It is necessary to calibrate the analyzer after reloading correction constants. Refer to Chapter 2 in this service guide to perform the following adjustments.

- Performing the CAL FREQ Adjustment Routine (*for all HP 8590 E-Series and L-Series spectrum analyzers, HP 8591C cable TV analyzers and HP 8594Q QAM analyzers*)
- Performing the CAL AMPTD Adjustment Routine (*for all HP 8590 E-Series and L-Series spectrum analyzers, HP 8591C cable TV analyzers and HP 8594Q QAM analyzers*)
- Performing the CAL YTF Adjustment Routine (*for the HP 8592L, HP 8593E, HP 8595E or HP 8596E spectrum analyzers only*)
- Performing the CAL MXR Adjustment Routine (*for the HP 8592L, HP 8593E, HP 8595E or HP 8596E spectrum analyzers only*)
- Adjusting the Display (*for all HP 8590 E- and L-Series spectrum analyzers, HP 8591C cable TV analyzers and HP 8594Q QAM analyzers*)
- Adjusting the Time and Date (*for all HP 8590 E-Series and L-Series spectrum analyzers, HP 8591C cable TV analyzers and HP 8594Q QAM analyzers*)

The analyzer should now be fully restored to its previous state.

### Correction Constant Backup-Data Record

Hewlett-Packard Company	Spectrum Analyzer Model: _____
Serial No. _____	Date _____

**Table 3-1.**  
**RTXO Timebase Correction Constant (Instruments without precision frequency reference)**

Timebase	_____
----------	-------

**Table 3-2.**  
**Frequency Response Correction Constants for the HP 8590L, HP 8591C, or HP 8591E**

Frequency (MHz)	Error (dB)*	Frequency (MHz)	Error (dB)*	Frequency (MHz)	Error (dB)*	Frequency (MHz)	Error (dB)*
4	_____	485	_____	966	_____	1447	_____
41	_____	522	_____	1003	_____	1484	_____
78	_____	559	_____	1040	_____	1521	_____
115	_____	596	_____	1077	_____	1558	_____
152	_____	633	_____	1114	_____	1595	_____
189	_____	670	_____	1151	_____	1632	_____
226	_____	707	_____	1188	_____	1669	_____
263	_____	744	_____	1225	_____	1706	_____
300	_____	781	_____	1262	_____	1743	_____
337	_____	818	_____	1299	_____	1780	_____
374	_____	855	_____	1336	_____	1817	_____
411	_____	892	_____	1373	_____		_____
448	_____	929	_____	1410	_____		_____

\* Instruments equipped with 75 Ω Input Impedance, display dBmV.

### Correction Constant Backup-Data Record

Hewlett-Packard Company	Analyzer Model: _____
Serial No. _____	Date _____

**Table 3-3.**  
**Frequency-Response Correction Constants**  
**for HP 8592L, HP 8593E, HP 8594E, HP 8594L, HP 8594Q, HP 8595E,**  
**or HP 8596E**  
**Band 0**

Frequency (GHz)	Error (dB)	Frequency (GHz)	Error (dB)	Frequency (GHz)	Error (dB)	Frequency (GHz)	Error (dB)
0.012	_____	0.804	_____	1.596	_____	2.388	_____
0.084	_____	0.876	_____	1.668	_____	2.460	_____
0.156	_____	0.948	_____	1.740	_____	2.532	_____
0.228	_____	1.020	_____	1.812	_____	2.604	_____
0.300	_____	1.092	_____	1.884	_____	2.676	_____
0.372	_____	1.164	_____	1.956	_____	2.748	_____
0.444	_____	1.236	_____	2.028	_____	2.820	_____
0.516	_____	1.308	_____	2.100	_____	2.892	_____
0.588	_____	1.380	_____	2.172	_____		
0.660	_____	1.452	_____	2.244	_____		
0.732	_____	1.524	_____	2.316	_____		

**Table 3-4.**  
**Frequency-Response Correction Constants**  
**for HP 8592L, HP 8593E, HP 8595E, or HP 8596E**  
**Band 1**

Frequency (GHz)	Error (dB)	Frequency (GHz)	Error (dB)	Frequency (GHz)	Error (dB)	Frequency (GHz)	Error (dB)
2.7500	_____	3.9245	_____	5.0990	_____	6.235	_____
2.9849	_____	4.1594	_____	5.3339	_____	6.5084	_____
3.2198	_____	4.3943	_____	5.5688	_____		
3.4547	_____	4.6292	_____	5.8037	_____		
3.6896	_____	4.8641	_____	6.0386	_____		



### Correction Constant Backup-Data Record

Hewlett-Packard Company	Analyzer Model: _____
Serial No. _____	Date _____

**Table 3-5.**  
**Frequency-Response Correction Constants**  
**for HP 8592L, HP 8593E, or HP 8596E**  
**Band 2**

Frequency (GHz)	Error (dB)	Frequency (GHz)	Error (dB)	Frequency (GHz)	Error (dB)	Frequency (GHz)	Error (dB)
6.100	_____	7.940	_____	9.780	_____	11.620	_____
6.284	_____	8.124	_____	9.964	_____	11.804	_____
6.468	_____	8.308	_____	10.148	_____	11.988	_____
6.652	_____	8.492	_____	10.332	_____	12.172	_____
6.836	_____	8.676	_____	10.516	_____	12.356	_____
7.020	_____	8.860	_____	10.700	_____	12.540	_____
7.204	_____	9.044	_____	10.884	_____	12.724	_____
7.388	_____	9.228	_____	11.068	_____		
7.572	_____	9.412	_____	11.252	_____		
7.756	_____	9.596	_____	11.436	_____		

**Table 3-6.**  
**Frequency-Response Correction Constants**  
**for HP 8592L or HP 8593E**  
**Band 3**

Frequency (GHz)	Error (dB)	Frequency (GHz)	Error (dB)	Frequency (GHz)	Error (dB)	Frequency (GHz)	Error (dB)
12.450	_____	14.290	_____	16.130	_____	17.970	_____
12.680	_____	14.520	_____	16.360	_____	18.200	_____
12.910	_____	14.750	_____	16.590	_____	18.430	_____
13.140	_____	14.980	_____	16.820	_____	18.660	_____
13.370	_____	15.210	_____	17.050	_____	18.890	_____
13.600	_____	15.440	_____	17.280	_____	19.120	_____
13.830	_____	15.670	_____	17.510	_____	19.350	_____
14.060	_____	15.900	_____	17.740	_____		

### Correction Constant Backup-Data Record

Hewlett-Packard Company	Analyzer Model: _____
Serial No. _____	Date _____

**Table 3-7.**  
**Frequency-Response Correction Constants**  
**for HP 8592L or HP 8593E**  
**Band 4**

Frequency (GHz)	Error (dB)	Frequency (GHz)	Error (dB)	Frequency (GHz)	Error (dB)	Frequency (GHz)	Error (dB)
19.150	_____	19.900	_____	20.650	_____	21.400	_____
19.300	_____	20.050	_____	20.800	_____	21.550	_____
19.450	_____	20.200	_____	20.950	_____	21.700	_____
19.600	_____	20.350	_____	21.100	_____	21.850	_____
19.750	_____	20.500	_____	21.250	_____	22.000	_____

**Table 3-8.**  
**Frequency-Response Correction Constants**  
**for HP 8592L or HP 8593E**  
**Band 4 (Option 026)**

Frequency (GHz)	Error (dB)	Frequency (GHz)	Error (dB)	Frequency (GHz)	Error (dB)	Frequency (GHz)	Error (dB)
19.100	_____	21.024	_____	22.948	_____	24.872	_____
19.248	_____	21.172	_____	23.096	_____	25.020	_____
19.396	_____	21.320	_____	23.244	_____	25.168	_____
19.544	_____	21.468	_____	23.392	_____	25.316	_____
19.692	_____	21.616	_____	23.540	_____	25.464	_____
19.840	_____	21.764	_____	23.688	_____	25.612	_____
19.988	_____	21.912	_____	23.836	_____	25.760	_____
20.136	_____	22.060	_____	23.984	_____	25.908	_____
20.284	_____	22.208	_____	24.132	_____	26.056	_____
20.432	_____	22.356	_____	24.280	_____	26.204	_____
20.580	_____	22.504	_____	24.428	_____	26.352	_____
20.728	_____	22.652	_____	24.576	_____	26.500	_____
20.876	_____	22.800	_____	24.724	_____		_____

### Correction Constant Backup-Data Record

Hewlett-Packard Company	Analyzer Model: _____
Serial No. _____	Date _____

**Table 3-9. A12 Step-Attenuator Correction Constants**

Attenuator Step	ERR (dB)	Attenuator Step	ERR (dB)
1 dB	_____	4 dB	_____
2 dB	_____	8 dB	_____
		16 dB	_____

**Table 3-10. CALTGX Correction Constants (Options 010 and 011)**

Slope	_____
Offset	_____

## Troubleshooting the Analyzer

---

This chapter provides information that is useful when starting to troubleshoot an analyzer failure. It provides procedures for troubleshooting common failures and isolating problems in the analyzer.

Additional troubleshooting details for specific assemblies are available in Chapter 5 and Chapter 6 of this service guide. Assembly descriptions are located in Chapter 9.

Component-level information for the HP 8590 E-Series and L-Series spectrum analyzers, HP 8591C cable TV analyzers, HP 8594Q QAM analyzers is provided in the *HP 8590 Series Analyzers Component-Level Repair Service Guide* binder. Refer to Chapter 12 for a list of available component-level service information.

---

### Before You Start

There are four things you should do before starting to troubleshoot a failure.

- Check that you are familiar with the safety symbols marked on the instrument, and read the general safety considerations and the safety note definitions given in the front of the this guide.
- The analyzer contains static sensitive components. Read the section entitled “Protection From Electrostatic Discharge” in Chapter 1.
- Become familiar with the organization of the troubleshooting information in this chapter and the chapters that follow.
- Read the rest of this section.

---

**Warning**      **The analyzer contains potentially hazardous voltages. Refer to the safety symbols on the analyzer and the general safety considerations at the beginning of this service guide before operating the unit with the cover removed. Failure to heed the safety precautions can result in severe or fatal injury.**

---

### Service equipment you will need

Refer to Table 1-7, “Recommended Test Equipment,” in Chapter 1 of the *HP 8590 Series Analyzers Calibration Guide* for a list of the recommended test equipment needed to troubleshoot and repair the analyzer. Although Hewlett-Packard equipment is recommended, any equipment that meets the critical specifications given in the table can be substituted for the recommended model.

Refer to Chapter 15 of this guide for a list of required service and hand tools needed to troubleshoot and repair the analyzer.

## Replacement assemblies

Some of the HP 8590 E-Series and L-Series spectrum analyzers, HP 8591C cable TV analyzer, and HP 8594Q QAM analyzer assemblies are not repairable to the component level. The following assemblies are not repairable to the component level and must be replaced as an assembly.

- A2 display
- A3 input attenuator (HP 8590L, HP 8591E, and HP 8591C only)
- A3A2 RF switch (HP 8592L, HP 8593E, HP 8595E, and HP 8596E only)
- A3A3 2.9 GHz low-pass filter (HP 8592L, HP 8593E, HP 8594E, HP 8594L, HP 8594Q, HP 8595E, and HP 8596E only)
- A3A4 second converter (HP 8592L, HP 8593E, HP 8594E, HP 8594L, HP 8594Q, HP 8595E, and HP 8596E only)
- A3A5 input attenuator (HP 8592L, HP 8593E, HP 8594E, HP 8594L, HP 8594Q, HP 8595E, and HP 8596E only)
- A3A6 dual mixer (HP 8592L, HP 8593E, HP 8595E, and HP 8596E only)
- A3A6 low band mixer (HP 8594E, HP 8594L, and HP 8594Q only)
- A3A7 YTO (HP 8592L, HP 8593E, HP 8594E, HP 8594L, HP 8594Q, HP 8595E, and HP 8596E only)
- A3A8 YTF (HP 8592L and HP 8593E only)
- A3A8 switched YTF (HP 8595E, and HP 8596E only)
- A3A9 321.4 MHz bandpass filter (HP 8592L, HP 8593E, HP 8594E, HP 8594L, HP 8594Q, HP 8595E, and HP 8596E only)
- A3A14 first LO distribution amplifier (Option 009, 010 only)
- A3A15 tracking generator (Option 010 only)
- A4 first converter (HP 8590L, HP 8591E, and HP 8591C only)
- A6 YTO (HP 8590L, HP 8591E, and HP 8591C only)
- A8 power supply
- A22 10 MHz precision frequency reference
- A25A1 sampler
- A26 TV tuner module (Option 107) *HP Qualified Service Center Only*
- A130 narrow bandwidth (Option 030 only)

Refer to Chapter 12 when ordering replacement assemblies.

## After an analyzer repair

If one or more analyzer assemblies have been repaired or replaced, perform the related adjustments and performance verification tests. Refer to Chapter 2 for a table of the related adjustments and performance verification tests required for each assembly.

---

## Problems at Instrument Power-Up

This section describes symptoms that can occur when the analyzer is first powered on.

---

**Caution** Immediately unplug the analyzer from the ac power line if the unit shows any of the following symptoms.

- Smoke, arcing, or unusual noise from inside the unit.
- No response of any kind when unit is plugged into ac power mains and turned on.
- The analyzer ac power fuse blows.
- A circuit breaker or fuse on the main ac power line opens.

These potentially serious faults must be corrected before proceeding. Refer to “Troubleshooting an Inoperative Analyzer.”

---

Note that analyzers equipped with the AM/FM speaker (Options 102, 103, or 110) normally emit noise from the speaker at power-up. This is not a problem, adjust the volume control as desired.

Table 4-1 lists symptoms that can occur when the instrument is first powered on. Refer to this table for an overview of symptoms at power-up and their possible cause.

**Table 4-1. Instrument Failure Symptoms at Power-On**

Line LED	A8 LED -15 V	A8 LED +15 V	A8 LED +5 V	A8 LED +12 V	B1 Fan	A2 Display	Possible Cause
ON	ON	ON	ON	ON	ON	ON	Normal Operation*
OFF	ON	ON	ON	ON	ON	ON	W1 wiring to Line LED, or Line LED
OFF	OFF	OFF	OFF	OFF	OFF	OFF	Line fuse, A8 primary circuit failure
ON	M	M	M	M	M	X	A8 primary overload
ON	OFF	ON	ON	ON	ON	X	-15 V supply failure
ON	OFF	M	M	M	M	X	-15 V supply overload
ON	ON	OFF	ON	ON	ON	X	+15 V supply failure
ON	M	OFF	M	M	M	X	+15 V supply overload
ON	M	M	OFF	M	M	X	+5 V supply failure or supply overload
ON	ON	ON	ON	OFF	OFF	OFF	+12 V supply failure
ON	M	M	M	OFF	OFF	OFF	+12 V supply overload
ON	ON	ON	ON	ON	OFF	ON	Fan failure or open along +12 V supply line to fan
ON	ON	ON	ON	ON	ON	OFF	No HPWRUP signal
ON	ON	ON	ON	ON	ON	X	A16 assembly failure
ON	ON	ON	ON	ON	ON	OFF	Display failure, intensity-control failure, or A16 memory failure
ON	ON	ON	ON	ON	ON	M	Intensity control failure, or A16 memory failure

M = LED or assembly is momentarily on, then goes off.  
X = Status of LED or assembly does not matter.

\* DS13 remains on after **PRESET** is pressed.

---

## Troubleshooting an Inoperative Analyzer

When an analyzer appears to be inoperative, there is often little evidence that points directly to the cause. This section provides steps and solutions to typical failure modes relating to an inoperative analyzer.

Before troubleshooting an analyzer, ensure that it has been set up correctly and the power supply is functioning properly by performing step 1 and step 2 below.

### Step 1. Check the Analyzer Setup

- ❑ Check that the voltage-selector switch on the rear of the A8 power supply is correct for the ac power line in use.
- ❑ Check that the ac line-power voltage is present and that the instrument line cord is in good condition.
- ❑ Check the line fuse. If it has blown, perhaps a nonstandard fuse with too low a current rating was installed. If the line fuse still blows, continue with the section entitled "If the line fuse has blown."

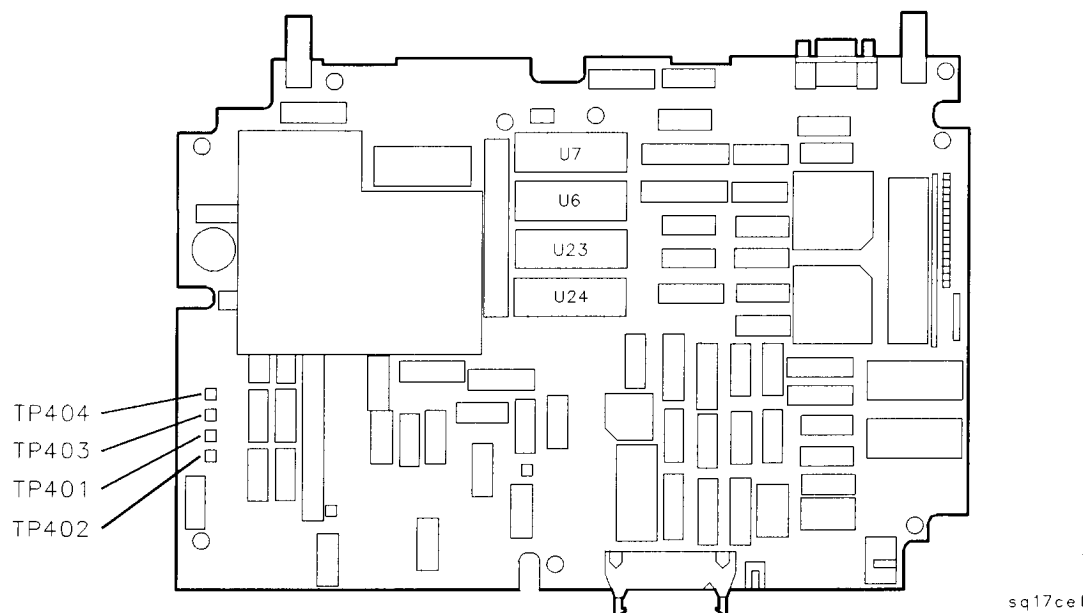
---

**Warning** For continued protection against fire hazard, replace fuse only with same type and ratings, (type 5A/250V). Failure to use the proper fuse specified for the analyzer can cause substantial instrument damage. The use of other fuses or materials is prohibited.

---

### Step 2. Check the Power Supply

The power supply voltages are checked using a digital voltmeter.



**Figure 4-1. A16 Power Supply Test Point Location**



1. Turn the analyzer **(LINE)** switch to OFF. Remove the instrument cover assembly.
2. Connect the DMM test leads from the chassis (ground) to A16TP403. See Figure 4-1.

---

**Warning**     **The analyzer contains potentially hazardous voltages. Refer to the safety symbols provided on the analyzer, and in the general safety instructions in this guide, before operating the unit with the cover removed. Ensure that safety instructions are strictly followed. Failure to do so can result in severe or fatal injury.**

---

3. Turn the analyzer **(LINE)** switch to ON.
4. Locate the power supply test point using Figure 4-1. Check the supply voltages as indicated in Table 4-2. Be sure the voltage readings are within the limits shown in Table 4-2.
5. Repeat step 4 for each power supply listed in Table 4-2.

**Table 4-2. Power Supply Tolerances**

<b>Power Supply</b>	<b>Test Point</b>	<b>Specification</b>
+5.1 V	A16TP403	+5.0 to +5.25 Vdc
+12.0 V	A16TP404	+11.1 to +12.8 Vdc
+15.0 V	A16TP401	+14.7 to +15.25 Vdc
-15.0 V	A16TP402	-14.7 to -15.25 Vdc

## If the line fuse has blown

If the instrument was set up correctly, and the line fuse still blows, suspect that the power supply is defective.

---

**Caution** The A8 power supply assembly is a switching power-supply and does not operate normally without a load on the dc power-supply outputs. Do not attempt to operate the power supply out of the instrument. Damage to the power supply may occur.

---

## If the fan is not operating

---

**Caution** The A8 power supply may be hot if the instrument has been operating without the fan running. Allow the instrument to cool down before troubleshooting.

---

The B1 Fan receives +12 Vdc from the A8 power supply after the power supply receives the start-up signal, low-power-on (LPWRON) from the front-panel LINE switch. First check the +12 Vdc supply to the fan at the Rear Frame.

1. Disconnect the line-power cord from the analyzer.
2. Look through the fan grill. If the cables routed near the fan are jammed in the fan, remove the fan from the rear frame, reroute the cables, and remount the fan.
3. Remove the fan from the rear frame and disconnect its wiring connector from A15J19.
4. Reconnect line power to the analyzer and turn it on.
5. Refer to "A15 Motherboard Assembly" in Chapter 5 for the pin identification of the fan-supply connector, A15J19, and the A8 power-supply connector, A8J1.
6. Check that pin 2 on A15J19 is connected to digital common-ground (DCOM). If the ground connection is open, suspect the A15 Motherboard.
7. Check pin 1 on A15J19 for +12 Vdc.

If the +12 Vdc is present, check for a defective B1 fan assembly by connecting the fan to an external DC supply.

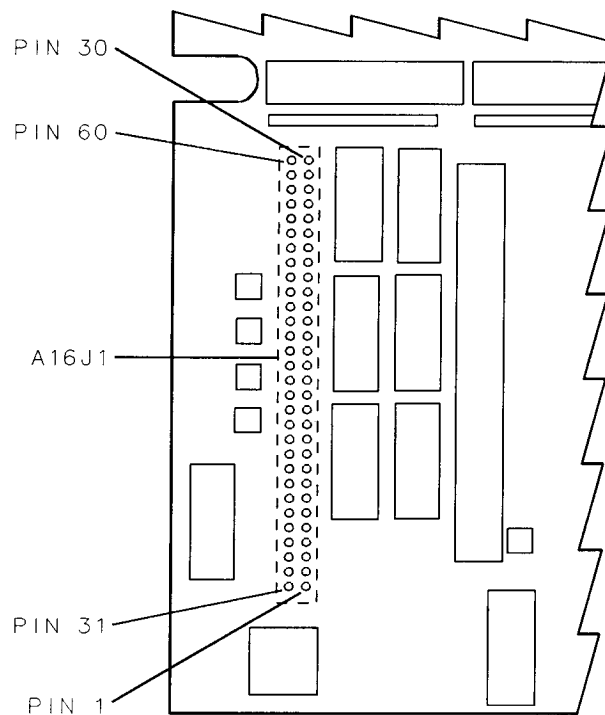
If the +12 Vdc is absent, do the following:

- Disconnect the analyzer from the line power.
- Remove the A8 power supply.
- Check the continuity of the A15 motherboard from pin 1 on A15J19 to pin 8 on A15J13.
- If the continuity of the motherboard is correct, suspect a bad connection on the D sub-connector (between pin 8 on A15J13 and pin 8 on A8J1) or a defective power supply.

## If all the A8 power-supply LEDs are off

If all the power-supply LEDs remain off, the low-power-on (LPWRON) control line must be checked from the front-panel line switch, through the A16 processor/video assembly and A15 Motherboard, to the A8 power supply.

1. Disconnect the analyzer line-power cord, remove the instrument cover, and turn the instrument so its bottom side faces up.
2. Check that the line switch provides the correct LPWRON signal at pin 2 on A16J9.
  - LPWRON becomes TTL low when the line switch is on. The closed switch connects A16J9 pin 2 to the digital common-ground (DCOM) through the W1 wiring harness.
  - LPWRON is pulled TTL high by the power supply when the line switch is in STANDBY.
3. Check the continuity of the LPWRON signal trace from pin 2 on A16J9 to pin 19 on A15J13. Refer to Figure 4-2 for the pin designations of the A15J13 connector.
4. Refer to “A15 Motherboard Assembly” in Chapter 5 for the connector-pin designations of the A16 and A15 assemblies.
5. If the LPWRON signal path from the previous step is correct, suspect a bad connection on the D sub-connector (between pin 19 on A15J13 and pin 19 on A8J1) or a defective power supply. Isolate the failure to the power supply by substituting another power supply assembly into the analyzer.



sh235e

**Figure 4-2. A15J13 Connector-Pin Designation**

### **If individual A8 power-supply LEDs are off**

If one or more of the A8 power-supply LEDs remain off, determine whether the power supply is defective or circuitry on the dc power-supply distribution network is loading the power supply down by substituting another power supply assembly.

### **If all the A8 power-supply LEDs are on**

If all the A8 power-supply LEDs are on, check the dc power-supply voltages on the A16 processor/video assembly. Check each voltage at the A16 assembly test points, TP401 through TP404. Refer to foldout 9-1 for the dc-voltage assignment of each test point.

If a dc voltage is missing, suspect an open connection in the dc power-supply distribution network. Refer to “A15 Motherboard Assembly” in Chapter 5 for the connector-pin designation of each assembly connected to the missing dc voltage supply.

### **If Using Defaults <N> is displayed**

A dead BT101 battery will cause the loss of all correction-factor and correction-constant data. When the data stored in memory is lost, the analyzer substitutes the default-correction data stored in ROM and performs the instrument-preset routine. The message Using Defaults <N> will appear on the analyzer display (where N is an integer that represents a code that was used during the development of the analyzer firmware.)

If the battery is dead, replace the battery as described in Chapter 7, then reload the correction constants as described in Chapter 3 of this service guide.

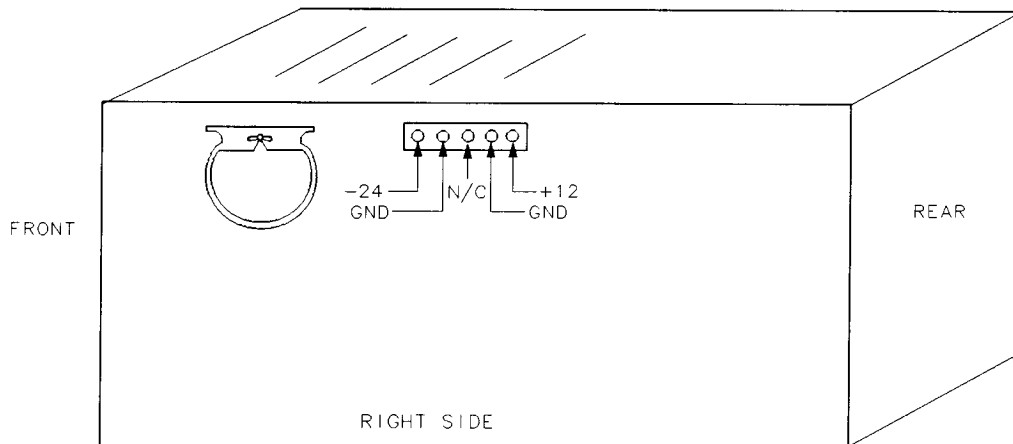
## Troubleshooting the A2 Display Assembly

Use this section when the A8 power supply is functioning but there appears to be a defective A2 display assembly. Check the following conditions before proceeding with the A2 display troubleshooting procedures.

- Check that the B1 Fan is running and the green LED above the **LINE** switch is on when the analyzer is on. If they are not operating, refer to the appropriate section of “Troubleshooting an Inoperative Analyzer.”
- Check the five LEDs on the A8 power supply assembly. If they are not on, refer to the appropriate section of “Troubleshooting an Inoperative Analyzer.”

Note that the A8 power supply draws current whenever ac line power is applied, even when the LINE switch is in the STANDBY position. However, no voltages are distributed outside the A8 power supply assembly when the LINE switch is in the STANDBY position, except for a TTL high on LPWRON.

- Check the dc power supplied to the A2 display. There is a separate 12 V supply for the display assembly. This supply can be checked at the output connector, A8J6, located on the right side of the A8 power supply. Refer to Figure 4-3. If there is a failure, check the continuity of the cable assembly W51 supplying the display, and the integrity of the power supply using the procedures in this chapter.



sh281e

**Figure 4-3. Detail of Power Supply Connector, A8J6**

---

**Warning**      **High voltage is present within the A2 display and remains for some time after it has been disconnected. Be careful while troubleshooting the display outside of its enclosure.**

---

If an A2 display assembly failure is suspected, the display must be removed from its enclosure for further troubleshooting. Refer to the A2 display assembly removal procedure in Chapter 3 before checking the continuity of the W2 and W3 wire harnesses. If both W2 and W3 are good, suspect the A2 display.

The A2 display is not field-repairable, and must be replaced as an assembly. Refer to Chapter 12 for HP part number information.

After replacement, adjust the new display, refer to Chapter 2.

### **If the display has an intensity problem**

---

**Caution**      The A1R1 potentiometer leads are easily broken. Do not twist the W3 wire harness where it attaches to A1R1.

---

1. Disconnect W3 from the A1R1 intensity control potentiometer on the front frame.
2. Check the continuity and resistance range ( 0 to 100 k $\Omega$ ) of the inner potentiometer on A1R1.
3. Reconnect W3 to A1R1.

### **If the display is blank**

1. Verify the MONITOR OUTPUT, located on the analyzer rear frame, by performing the following:
  - Attach an external monitor to the MONITOR OUTPUT connector. The MONITOR OUTPUT is a NTSC composite video with horizontal at 15.75 kHz and a vertical rate of 60 Hz.
  - Adjust the horizontal hold on the external monitor, if necessary.

If a normal instrument display is present, the display failure is limited to the A2 display and its related circuitry.

2. Verify the output of the drive circuitry from the A16 processor/video assembly to the A2 display by performing the following steps.

- Position the analyzer with the bottom side facing up.

---

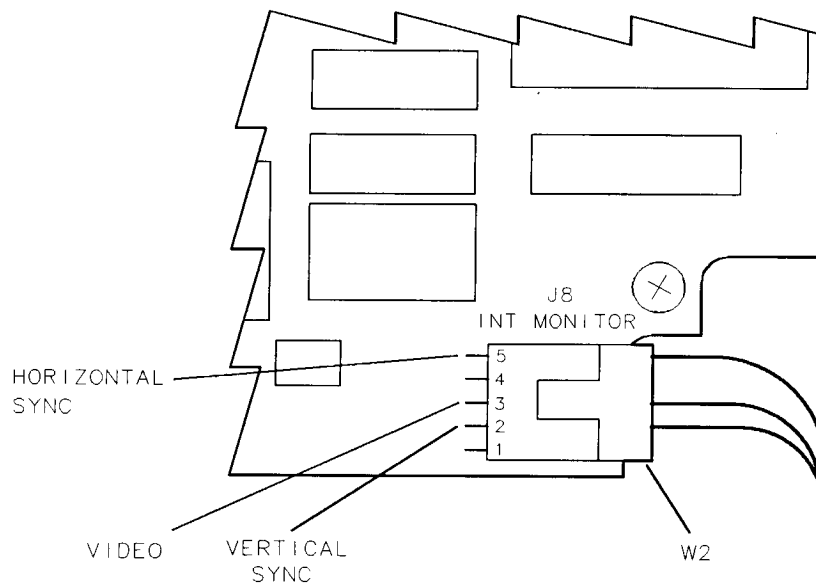
**Caution** Do not short any two of the A16J8 pins together. Damage to the output buffer amplifiers located on the processor/video assembly may occur.

---

- Disconnect the W2 wire harness.
- Refer to Figure 4-4 for the location of the test points and check the following signals at A16J8 pins, using an oscilloscope.
  - Check for a 60 Hz TTL signal with a pulse width of approximately 0.2 ms and a repetition rate of approximately 18 ms at pin 2, vertical sync signal.
  - Check for an approximately 2.5 V pk-pk video signal at pin 3, video signal.
  - Check for a 15.75 kHz TTL signal with a pulse width of approximately 10  $\mu$ s and a repetition rate of approximately 64  $\mu$ s at pin 5, horizontal sync signal.

If the video, horizontal, and vertical signals are missing, but the +12 V supply voltage is present, continue with step 3.

3. Check the +12 Vdc power supplied to the A2 display. There is a separate 12 V supply for the display assembly. This supply can be checked at the output connector, A8J6, located on the right side of the A8 power supply. Refer to Figure 4-3. If there is a failure, check the continuity of the cable assembly W51 supplying the display, and the integrity of the power supply using the procedures in this chapter.



sh237e

**Figure 4-4. A16J8 Display Signal Output Pins**

4. Verify the High-Power-Up signal from the A8 power supply by checking for the +5 V TTL HPWRUP signal at pin 54 on the A16J1. The A16J1 connector is on the trace side of the A16 processor/video assembly. Refer to Figure 4-5 for the numbering order of A16J1 connector-pins accessible from the component side of the A16 processor/video assembly.

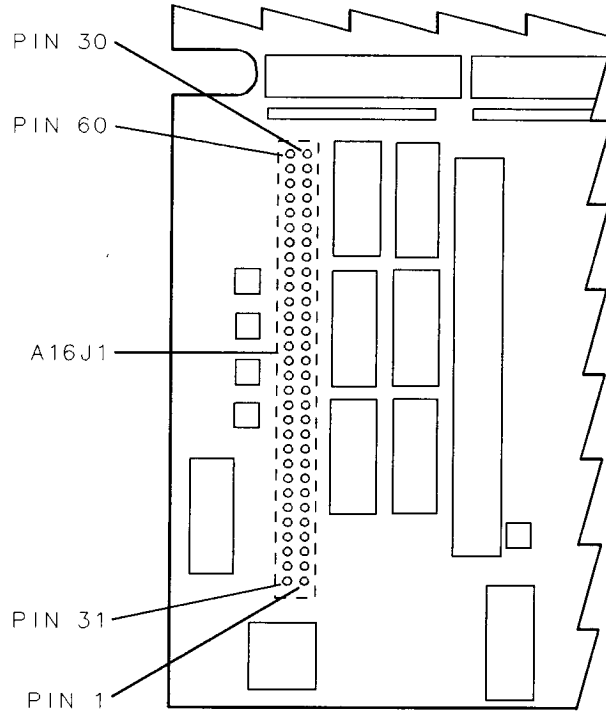
Note that the A8 power supply assembly sends the high-power-up (HPWRUP) signal to the A16 processor/video assembly after it receives the low-power-on (LPWRON) signal and the +5 V supply has stabilized. If HPWRUP is low, the display remains blank and the A16 failure LEDs (DS1 through DS16) will not come on during power-up.

- If the HPWRUP signal is missing, trace the signal back through the A15 motherboard to the A8 power supply assembly, pin 37 on A8J1. Refer to “A15 Motherboard Assembly” in Chapter 5 for the connector-pin designation of the HPWRUP signal path.

Note that if your analyzer is an HP 8590 E-Series, HP 8591C, or HP 8594Q QAM analyzer, the HPWRUP signal can be measured on pin 55 of each card-cage slot on the A15 motherboard. Refer to Figure 4-6 for the numbering order of the connector pins on A15J3 through A15J6.

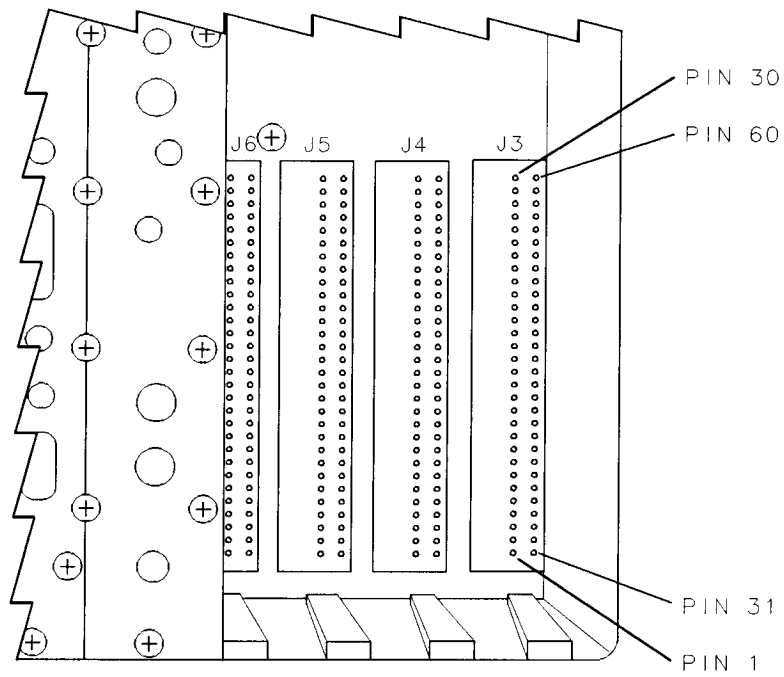
- If the HPWRUP signal is present, yet one or more of the A16 processor/video assembly outputs is incorrect, suspect a defective A16 processor/video assembly. Before replacing the A16 processor/video assembly, refer to Chapter 3 in this service guide.
- If all the A16 display outputs are correct, suspect a defective A2 display.





sh238e

**Figure 4-5. A16J1 Connector-Pin Orientation**



sh239e

**Figure 4-6. Card-Cage Connector-Pin Orientation**

---

## Isolating an RF, LO, IF, or Video Problem

This section provides techniques for isolating amplitude failures along the signal path from the analyzer input to the A16 processor/video assembly. These troubleshooting methods isolate the failure to one of four functional sections in the analyzer.

- The RF section. This section includes the assemblies from the analyzer input to the input of the A9 third converter assembly.
- The LO section. This section involves the assemblies that provide a local oscillator output to the RF section. The A25 counterlock assembly is one of the assemblies involved (for counterlocked analyzers only).
- The IF section. This section includes the assemblies from the input of the A9 third converter to the output of the A14 log amplifier assembly.
- The video section. This includes the circuitry from the output of the A14 log amplifier assembly to the ADC section on the A16 processor/video. This section of the analyzer processes the detected 21.4 MHz IF signal from the IF section.

### Procedure for Isolating an RF, LO, IF, or Video Failure

Perform the following procedure to isolate an RF, LO, IF, or Video problem.

1. With the failure symptoms present, switch the analyzer from positive-peak detector to sample-detector mode.
  - If the analyzer returns to normal operation, the positive-peak detector is defective.
  - If the failure symptoms remain, continue with the next step.
2. Verify the 2 V reference detector and the ground reference detector are operating properly by performing the internal service-diagnostic routines in this chapter.
  - If either the 2 V or ground reference detectors are not operating properly, suspect the ADC circuitry on the A16 processor/video board assembly.
  - If the 2 V or ground reference detectors are functioning properly, continue with the next step.
3. Use the display calibration data to find the DAC value used to adjust the gain at the output of the A9 third converter assembly. The DAC value is in the REF LVL CAL DAC block. Refer to the internal service-diagnostic routines in this chapter.

The DAC value is unique for each analyzer. The CAL AMPTD self-calibration routine adjusts this value based on the amplitude of the digitized video signal on the processor/video board assembly. The calibration routine makes this adjustment while calibrating the reference level at top screen.

After running the CAL AMPTD calibration routine, the REF LVL CAL DAC has a typical value of 165 with a range of 130 to 185. The higher the DAC value, the greater the output from the A9 third converter assembly.

4. Check the signal path from the analyzer input to the output of the A14 log amplifier assembly. Refer to “IF Power-Level Measurement” located in Chapter 5 of this guide.
5. Measure the 321.4 MHz input to the A9 third converter assembly by connecting the CAL OUT to the INPUT 50Ω with a BNC cable.

*75 Ω input only:* Connect the CAL OUT to the INPUT 75Ω with the 75 Ω BNC cable.

Then, disconnect the W9 cable assembly from the third converter and measure at the cable output.

The 321.4 MHz input typically measures between –36 and –39 dBm with zero input attenuation.

- If the REF LVL CAL DAC value is 255 and the input to the A9 third converter assembly is above the test limit, suspect a low gain problem in the IF section. Continue with the troubleshooting procedures in “IF Power-Level Measurement.”
  - If the REF LVL CAL DAC value is 0 and the input to the A9 third converter assembly is nominal, suspect a high gain problem in the IF section. Continue with the troubleshooting procedures in “IF Power-Level Measurement.”
  - If the REF LVL CAL DAC value is 255 and the input to the A9 third converter is below the test limit, suspect a low gain problem in the RF/LO sections. Continue with the next step.
  - If the REF LVL CAL DAC value is 0 and the input to the A9 third converter is above the test limit, suspect a high gain problem in the RF section. Continue with the next step.
6. Set up the analyzer as shown in “Instrument Settings for RF Power-Level Measurement” in this chapter.
  7. Isolate the failure to an RF or LO assembly by performing the RF Power-Level Measurements procedure in Chapter 6 of this guide.

Once the problem has been isolated to one of the four sections, use standard troubleshooting methods to locate the source of the failure.

The following failure symptoms are examples to help isolate a failure to either the RF, LO, IF, or Video sections.

### **If there is only a horizontal trace with no signal or noise floor present**

1. Check for a peak-detector failure by switching between the positive-peak detector and sample detector modes.
2. Perform the 2 V reference detector and ground reference detector diagnostic routines. Refer to “Using the Internal Service-Diagnostic Routines” in this chapter.
3. Check the signal path from the analyzer input to the output of the A14 log amplifier assembly. Refer to “IF Power-Level Measurement” located in Chapter 5 of this service guide.

## If the analyzer displays a low signal level

A low signal level can cause the CAL AMPTD self-calibration routine to stop if the REF LVL CAL DAC reaches 255. The routine does not store the correction factors from an incomplete calibration; however, the corrections from the incomplete calibration are temporarily retained and can be viewed by displaying the calibration data (DISPLAY CAL DATA) as described in “Using the Internal Service-Diagnostic Routines.” Refer to Chapter 14 for a description of the displayed error message.

Perform the following steps to help isolate the problem.

1. Check the amplitude of the CAL OUT signal and ensure that the CAL OUT signal is properly connected to the analyzer input. (The self-calibration routines perform an initial setup check. If the signal level is below  $-40$  dBm, the routine fails.)
2. Use DEFAULT CAL DATA to set the REF LVL CAL DAC to a default value of 200 by pressing the following analyzer keys.

```
FREQUENCY – 2001 (Hz)
CAL More 1 of 4 More 2 of 4
DEFAULT CAL DATA
```

3. Check the signal path from the analyzer input to the output of the A14 log amplifier assembly. Refer to “IF Power-Level Measurement” located in Chapter 5 of this service guide.

## If the analyzer displays a high noise floor

This problem can be due to low gain somewhere along the RF or IF signal path.

The CAL AMPTD self-calibration routine compensates for the low gain by increasing the gain of the A9 Third Converter assembly using the REF LVL CAL DAC. The excessive gain may cause the high noise floor by amplifying the noise level from the RF section, or over-driving a stage in the IF section.

The analyzer may also fail the displayed average noise performance verification test.

1. Check the REF LVL CAL DAC value using DISPLAY CAL DATA as described in “Using the Internal Service-Diagnostic Routines.” This type of problem causes the DAC value to be close to the 255 maximum.
2. Measure the 321.4 MHz input to the A9 third converter assembly by connecting the CAL OUT to the INPUT  $50\Omega$  with a BNC cable.

*75  $\Omega$  input only:* Connect the CAL OUT to the INPUT  $75\Omega$  with the  $75\Omega$  BNC cable.

Then, disconnect the W9 cable assembly from the third converter and measure at the cable output.

The 321.4 MHz input typically measures between  $-36$  and  $-39$  dBm with zero input attenuation.

3. Check the signal path from the analyzer input to the output of the A14 log amplifier assembly. Refer to “IF Power-Level Measurement” located in Chapter 5 of this service guide.

## If the displayed signal amplitude appears too high

This problem is caused by high gain somewhere along the RF or IF signal path. The displayed CAL OUT signal appears to have an amplitude greater than  $-20$  dBm. The excessive gain causes a calibration error that makes the CAL OUT signal appear higher than normal.

The CAL AMPTD self-calibration routine may not fail.

- Check for a REF LVL CAL DAC value of 0 using DISPLAY CAL DATA as described in “Using the Internal Service-Diagnostic Routines.” The values in the ERR column are 0.00 or have a negative value.
- Measure the 321.4 MHz input to the A9 third converter assembly by connecting the CAL OUT to the INPUT  $50\Omega$  with a BNC cable.

*75  $\Omega$  input only:* Connect the CAL OUT to the INPUT  $75\Omega$  with the  $75\Omega$  BNC cable.

Then, disconnect the W9 cable assembly from the third converter and measure at the cable output.

The 321.4 MHz input typically measures between  $-36$  and  $-39$  dBm with zero input attenuation.

- Check the signal path from the analyzer input to the output of the A14 log amplifier assembly. Refer to “IF Power-Level Measurement” located in Chapter 5 of this service guide.

## If the displayed signal is distorted

This failure may result in the displayed signal having distinct lobes on each side. A high noise floor may also be present.

Note that an intermittent hardware failure during the CAL AMPTD self-calibration routine can cause this type of amplitude failure. The erroneous calibration data causes the failure symptoms even while the hardware is operating normally.

1. If the signal looks normal when CORRECT ON OFF is off, check the values in the RFATN and SGAIN columns using DISPLAY CAL DATA as described in “Using the Internal Service-Diagnostic Routines.”

If a correction factor in either column is greater than two, there may be a failure on the input attenuator or the A12 amplitude control assembly.

Refer to Chapter 13 for the description of the corrections that are disabled when CORRECT ON OFF is off.

2. Troubleshoot the input attenuator or step gain symptoms with **CORRECT ON OFF** turned off.
3. Measure the 321.4 MHz input to the A9 third converter assembly by connecting the CAL OUT to the INPUT 50Ω with a BNC cable.

*75 Ω input only:* Connect the CAL OUT to the INPUT 75Ω with the 75 Ω BNC cable.

Then, disconnect the W9 cable assembly from the third converter and measure at the cable output.

The 321.4 MHz input typically measures between –36 and –39 dBm with zero input attenuation.

4. Check the signal path from the analyzer input to the output of the A14 log amplifier assembly. Refer to “IF Power-Level Measurement” located in Chapter 5 of this service guide.

Recalibration of the analyzer is necessary after the adjustment or replacement of each suspect assembly. A functioning analyzer may still appear to be defective if calibration data from before the repair is used.

### **If the signal is off frequency**

This failure may result in the **CAL FREQ** self-calibration routine failing.

Perform all of the internal service-diagnostic routines. Refer to “Using the Internal Service-Diagnostic Routines” in this chapter.

### **If the signal is off frequency in spans <10 MHz only**

1. Perform all of the internal service-diagnostic routines. Refer to “Using the Internal Service-Diagnostic Routines” in this chapter.
2. *For analyzers equipped with an A25 counterlock assembly only:* Disconnect the A25 counterlock assembly, perform the **FREQ CAL** calibration routine, then operate the analyzer as an unlock instrument.

If the analyzer is corrected, suspect the A25 counterlock assembly.

### **If the signal displays in low band only**

This symptom only applies to the HP 8592L, HP 8593E, HP 8594E, HP 8594L, HP 8594Q, HP 8595E, and HP 8596E spectrum analyzers.

Perform all of the internal service-diagnostic routines. Refer to “Using the Internal Service-Diagnostic Routines” in this chapter.

If the A7 Analog Interface board assembly appears to be functioning properly, see the appropriate section of Chapter 6 for your analyzer.

---

## Using the Internal Service-Diagnostic Routines

The HP 8590 E-Series and L-Series spectrum analyzers, HP 8591C cable TV analyzers, and HP 8594Q QAM analyzers have an internal service-diagnostics routine menu available within the calibration menus.

Reference voltages and ramps are routed through a MUX located on the A7 analog interface board assembly. These voltages and ramps can be displayed on the analyzer or on an oscilloscope by connecting a probe to A7TP2 when a service-diagnostic routine is performed. The only exception is the 2VREF and GNDREF, these reference voltages originate on the A16 processor/video board assembly.

The service-diagnostic routines included in this section are the most useful routines used to help isolate problems with the A7 analog interface and A16 processor/video board assemblies. Illustrations are included with each procedure to show the expected displayed results.

Access the service-diagnostic routine softkeys by pressing the following analyzer keys.

```
CAL More 1 of 4 More 2 of 4
SERV DIAG
```

Note that whenever an analyzer setting has been changed while in a service-diagnostic routine, you must return to the service-diagnostic routine softkey menu by pressing the key sequence listed above.

### If a flat line appears at midscreen

When a service-diagnostic routine is selected and only a flat line appears at midscreen, connect an oscilloscope to A7TP2. If the expected signal is there, then the ANA\_TEST line is either shorted or open. This can be caused by bent pins or solder bridges on either the A7, A16, or A15 board assemblies. This condition will cause the frequency calibration routine to fail, as it uses this line to set up the sweep ramp at the beginning of the calibration routine.

### If a service-diagnostic routine fails

When a service-diagnostic routine fails, it is recommended to continue verifying the rest of the service-diagnostic routines to isolate a failure for further troubleshooting. For example, the main coil driver is dependent on the sweep ramp and the  $-10$  V reference to function properly.

## Verify the displayed calibration data

1. Press the following analyzer keys.

**CAL** More 1 of 4 More 2 of 4

SERV DIAG

DISPLAY CAL DATA

2. Verify that the digital correction values are within their limits. Refer to Chapter 14 for typical examples of the calibration data displays.

- If default values are being used, all digital corrections should be zero.
- If corrections are being used, make sure that all digital corrections are present. Typical values should be below 1.00.

3. Return to the diagnostics menu by pressing the following analyzer keys.

**PRESET**

**FREQUENCY** BAND LOCK 0-2.9 GHz BAND 0 (except HP 8590L, HP 8591E, and HP 8594E)

**CAL** More 1 of 4 More 2 of 4

SERV DIAG More 1



## Verify the 2 V reference detector

This service-diagnostic routine verifies the 2 V reference circuitry on the A16 processor/video board.

Verify the 2 V reference by pressing **2V REF DETECTOR**.

- If the signal trace is at the top of the display, the 2 V reference is functioning properly. See Figure 4-7.
- If the signal is not at the top of the display, the problem is isolated to the A16 processor/video board assembly. Refer to "Troubleshooting the A16 Processor/Video Board Assembly," located in this chapter for further troubleshooting.

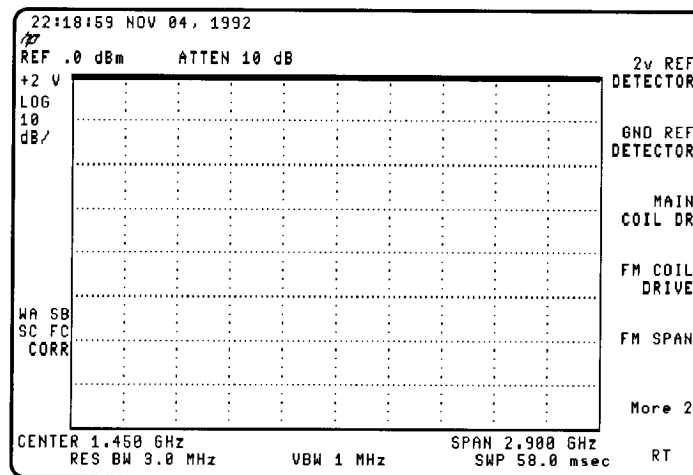


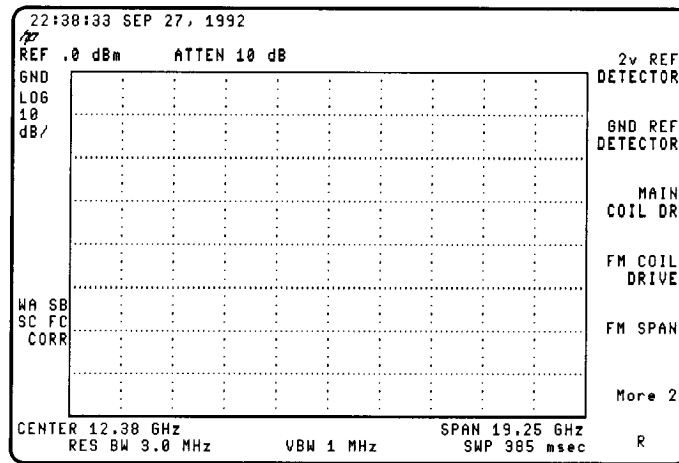
Figure 4-7. 2 V Reference Detector

## Verify the ground reference detector

This service-diagnostic routine verifies the ground reference circuitry on the A16 processor/video board.

Verify the ground reference by pressing **GND REF**.

- If the signal trace is at the bottom of the display, the ground reference is functioning properly. See Figure 4-8.
- If the signal is not at the bottom of the display, the problem is isolated to the A16 processor/video board assembly. Refer to "Troubleshooting the A16 Processor/Video Board Assembly," located in this chapter for further troubleshooting.



**Figure 4-8. Ground Reference Detector**

## Verify the main coil driver

This service-diagnostic routine verifies that the ramp is driving the YTO.

1. Select a single band (if more than one band is available on your analyzer).

Note that any band is acceptable unless the problem is isolated to a specific band. In that case, choose the appropriate band. Figure 4-9 uses Band 0 as an example.

2. Return to the diagnostics menu by pressing the following analyzer keys.

**FREQUENCY** BAND LOCK 0-2.9 GHz BAND 0

**CAL** More 1 of 4 More 2 of 4

**SERV DIAG** More 1

3. Verify the main coil driver by pressing **MAIN COIL DRIVE**.

- If the signal trace is similar to Figure 4-9, the main coil driver is functioning properly.
- If the signal is not similar, suspect the A7 analog interface assembly.

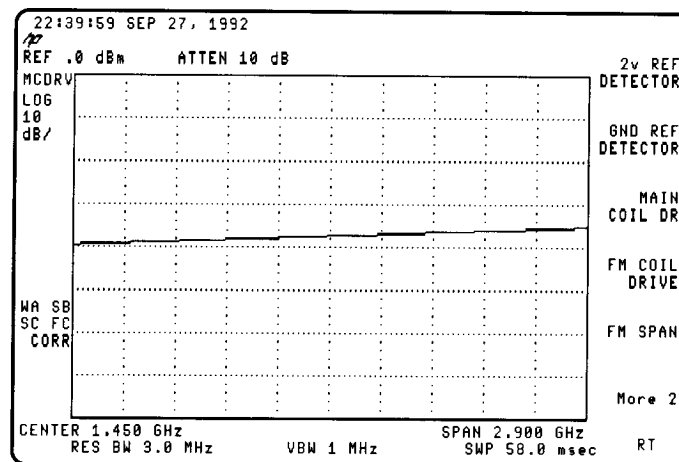


Figure 4-9. Main Coil Driver Typical Display

## Verify the FM coil driver

It is only necessary to perform this service-diagnostic routine if the failure appears in narrow spans (10 MHz and below).

1. Set the analyzer span to 10 MHz.

Be sure to set the span before performing the service-diagnostic routine. For example, if the span is not set first, the trace will appear at the top of the display instead of the expected ramp.

2. Return to the diagnostics menu by pressing the following analyzer keys.

```
CAL More 1 of 4 More 2 of 4
SERV DIAG More 1
```

3. Verify the FM coil driver by pressing **FM COIL DRIVE**.

- If the signal trace is similar to Figure 4-10, the FM coil driver is functioning properly.
- If the signal is not similar, suspect the A7 analog interface board assembly.
- *For analyzers equipped with an A25 counterlock assembly only:* If all other service-diagnostic routines operate properly, disconnect the A25 counterlock assembly, perform the **FREQ CAL** calibration routine, then operate the analyzer as an unlock instrument.

If the analyzer is corrected, suspect the A25 counterlock assembly.

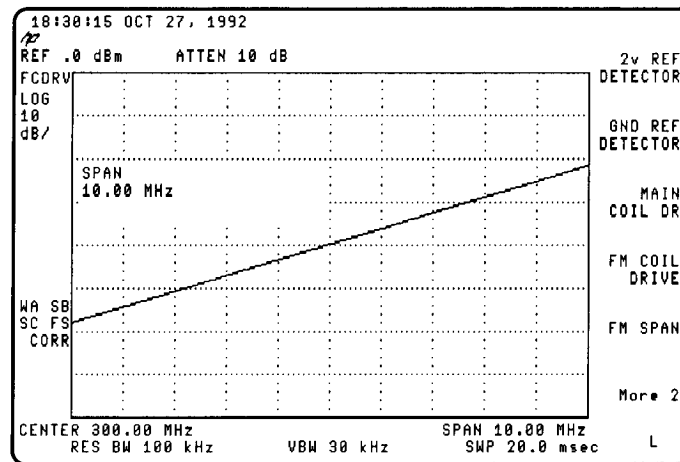


Figure 4-10. FM Coil Driver with  $\leq$  10 MHz Span

## Verify the FM coil driver for spans >10 MHz

It is only necessary to perform this service-diagnostic routine if the failure appears in spans wider than 10 MHz.

1. Set the analyzer span to 11 MHz.
2. Return to the diagnostics menu by pressing:  
**CAL** More 1 of 4 More 2 of 4  
**SERV DIAG** More 1
3. Verify the FM coil driver by pressing **FM COIL DRIVE**.

- If the signal trace is similar to Figure 4-11 the FM coil driver is functioning properly.
- If the signal is not similar continue with the next service-diagnostic routine.

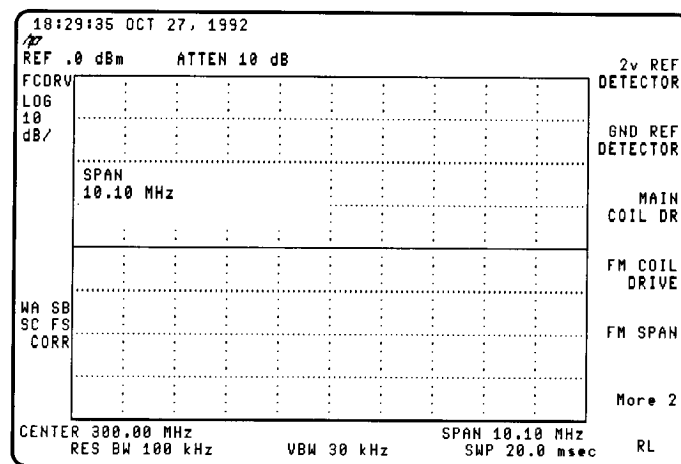


Figure 4-11. FM Coil Driver with >10 MHz Span

## Verify the sweep ramp

1. Verify the sweep ramp by pressing:

**SPAN**, 10 **MHz**, **CAL**, **More 1 of 4**, **More 2 of 4**,  
**SERV DIAG**, **More 1**, **More 2**, **SWEEP RAMP**

- If the signal trace is similar to Figure 4-12 the sweep ramp is functioning properly.

---

**Note** Before a successful frequency calibration is performed, the ramp will not be corner to corner, but will have some overshoot or undershoot.

---

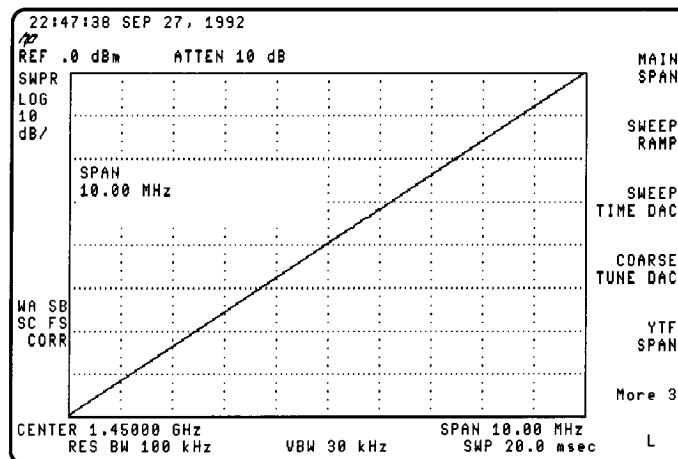
- If the signal is not similar suspect the A7 analog interface board assembly. Refer to Chapter 6 for further information about troubleshooting the A7 board assembly.

2. Change the analyzer sweep time.

---

**Note** It is recommended that all sweep times be checked due to the A7 analog interface board assembly operating differently for the different RC combinations. This can result in the analyzer appearing to operate properly in one sweep time and not in another.

---



**Figure 4-12. Typical Sweep Ramp Display**

## Verify the 10 V reference detector

This service-diagnostic routine verifies the 10 V reference. +10 V is used as a reference for the DACs and originates on the A7 analog interface board assembly. Frequency and amplitude errors will occur if this voltage is incorrect.

1. Return to the diagnostics menu by pressing the following analyzer keys.

**CAL** More 1 of 4 More 2 of 4

SERV DIAG More 1 More 2 More 3

2. Verify the 10 V reference detector by pressing **10V REF DETECTOR**.

- If the signal trace is at the top of the display, the 10 V reference detector is functioning properly. See Figure 4-13.
- If the signal is not at the top of the display, the problem is isolated to the A7 analog interface board assembly. Refer to Chapter 6 for further troubleshooting.

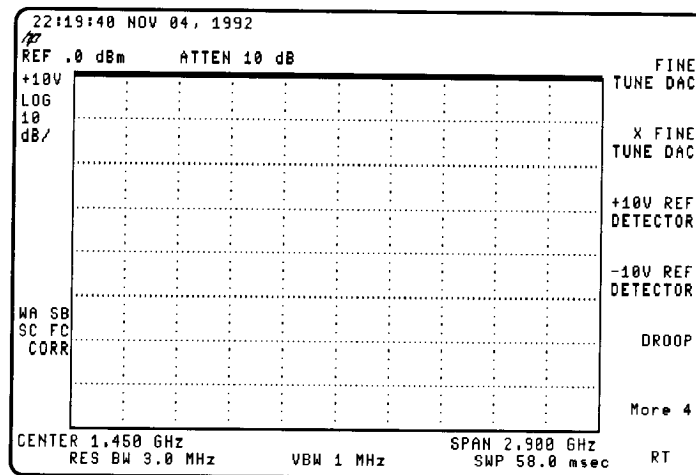


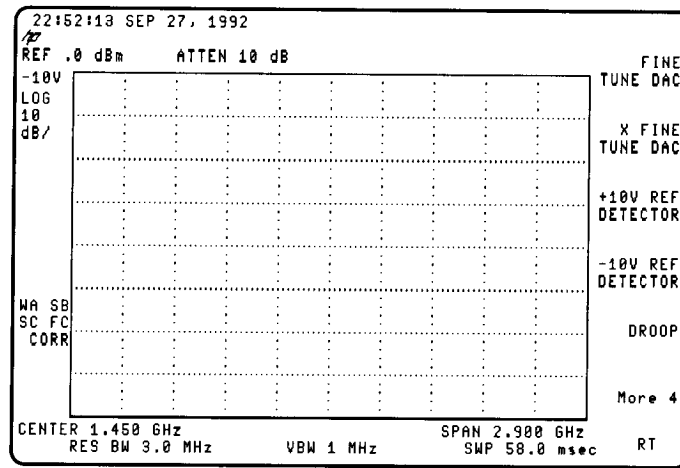
Figure 4-13. 10 V Reference Detector

## Verify the -10 V reference detector

This service-diagnostic routine verifies the -10 V reference. -10 V is summed with the tuning voltages and used in the main coil driver and originates on the A7 analog interface board assembly. Frequency and amplitude errors will occur if this voltage is incorrect.

Verify the -10 V reference detector by pressing **-10V REF DETECTOR**.

- If the signal trace is at the bottom of the display, the -10 V reference detector is functioning properly. See Figure 4-14.
- If the signal is not at the bottom of the display, the problem is isolated to the A7 analog interface board assembly. Refer to Chapter 6 for further troubleshooting.



**Figure 4-14. -10 V Reference Detector**



## Verify the YTF driver

This service-diagnostic routine applies only to the HP 8592L, HP 8593E, HP 8595E, and HP 8596E spectrum analyzers with high band problems. This routine verifies the YTF driver. The YTF is a sensitive device and the minimum of ramp voltage error can result in the YTF being out of specification.

1. Enter band 1 by pressing the following analyzer keys.

**FREQUENCY** BAND LOCK 2.75 - 6.5 BAND 1

Note that any band, other than band 0, is acceptable.

2. Verify the YTF driver by pressing:

**CAL**, More 1 of 4, More 2 of 4,

SERV DIAG, More 1, More 2, More 3, More 4, More 5,

YTF DRIVER

- Bands 2, 3, and 4 will have a similar display at different positions on the display.
- If the signal trace is similar to Figure 4-15, the YTF driver is functioning properly.
- If the signal is not similar, suspect the A7 analog interface board assembly. Refer to Chapter 6 for further information about troubleshooting the A7 board assembly.

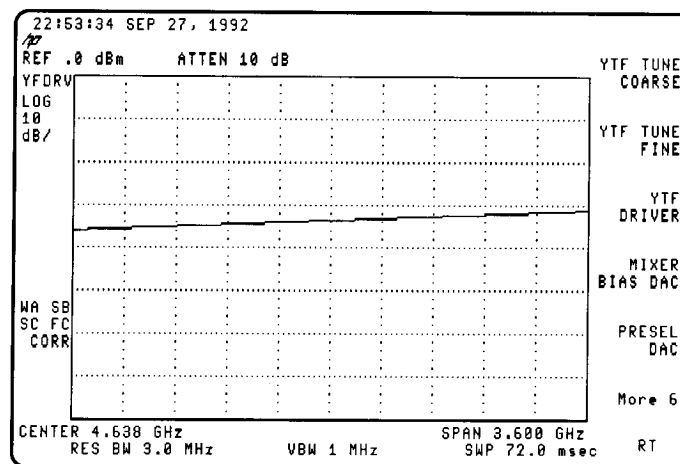


Figure 4-15. YTF Driver

---

## Troubleshooting the A16 Processor/Video Board Assembly

After you have determined that the problem is caused by the A16 processor/video assembly, use the following procedures. The *HP 8590 Series Analyzers Component-Level Repair Service Guide* is required to assist with these procedures. Refer to Chapter 12 for a list of available component-level service information.

### If a signal cannot be displayed

If a signal cannot be displayed, and it has been determined that a top-screen signal of two volts is present at VIDEO\_IF, the problem may be on the A16 processor/video board assembly.

1. Put 0 V into the video circuit, simulating a bottom-screen signal level condition by setting the diagnostic to the ground reference detector. Refer to “Verify the ground reference detector” located in this Chapter.

Use an oscilloscope to check for the following conditions. Refer to Sheet 2 of 4 of the A16 processor/video board assembly component-level information.

- Check for 0 V throughout the signal path through U201, U61, U45, and U46.
- Check the offset by measuring the inverting and noninverting pins on U201, U61, U45, and U46. The difference between both measured values should not exceed 5 mV.

2. Replace any components with excess offset voltage.

3. Put 2 V into the video circuit, simulating a top-screen signal level condition by setting the diagnostic to the 2 V reference detector. Refer to “Verify the 2 V reference detector” located in this chapter.

Use an oscilloscope to check for the following conditions. Refer to Sheet 2 of 4 of the A16 processor/video board assembly component-level information.

- Check for 2 V throughout the signal path through U201, U61, U45, and U46.
- Check the offset by measuring the inverting and noninverting pins on U201, U61, U45, and U46. The difference between both measured values should not exceed 5 mV.

4. Replace any components with excess offset voltage.

5. Switch between POS PEAK and SAMPLE detector modes. If the signal appears when in the SAMPLE detector, suspect something in the positive-peak detector circuit.

### If the analyzer does not respond (locked up)

If the analyzer is not responding or is continuously doing instrument presets, and cycling power does not correct the problem, perform the following steps.

1. Check for a defective Down Loadable Program (DLP) that has been installed into the analyzer.
2. Clear the user memory by performing the step, for your analyzer, listed below.

If the analyzer is equipped with Option 023 (RS-232 remote interface), connect it to a computer. Execute the Break command, and press the following analyzer keys.

**CONFIG** More 1 of 3 More 2 of 3

**DISPOSE USER MEM**

**DISPOSE USER MEM**

If the analyzer is equipped with Option 021 (HP-IB remote interface), connect it to a controller. Execute the following remote program line to erase user memory and clear the problem.

```
SEND 7;UNL MTA LISTEN 18 CMD 12
```

### Perform a free-run check

This procedure allows you to set the microprocessor to a known state so that certain basic functions can be checked. A MOVEQ instruction is read from the system data bus. The MOVEQ instruction may be thought of as a no operation (NOP) for this procedure. The microprocessor will increment the address lines A1 through A23, then continue to read data on the system data bus.

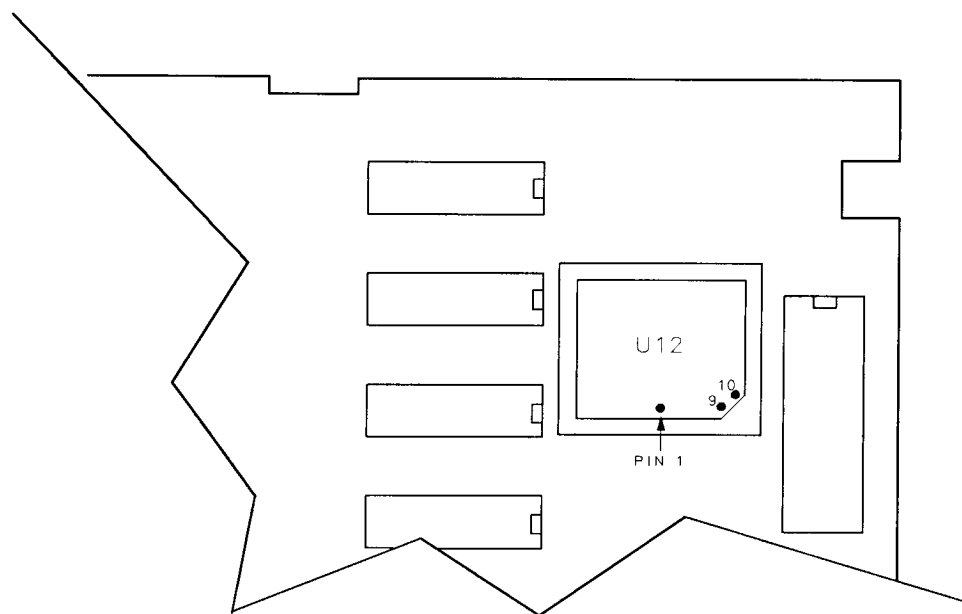
1. Turn the analyzer power off.
2. Remove A16U25 (16 pin DIP jumper pack.)
3. Connect a clip lead from A16TP1 pin 7 to ground.
4. Turn the analyzer power on.

---

**Caution** While measuring pins on the microprocessor chip, exerting too much pressure on a pin may cause one of the data lines to open. This may result in factory correction constants to be erased.

---

5. Check A16U12 for the conditions described in Table 4-3 while in the free-run mode. Refer to the component-level information for the A16 processor/video board assembly.



sh280e

**Figure 4-16. A16U12 Pin Location**

**Table 4-3. Free-Run Mode Test Points on A16**

<b>A16U12 Pin Location</b>	<b>A16U12 Free-Run Mode Condition</b>
6	AS is toggling
7	UDS is toggling
8	LDS is toggling
9	R/W is logical one
32-55	Address lines A1 through A23 are counting in binary <i>where:</i> <i>A1 (pin 32) = LSB</i>

6. Check for +5 V at pin 1 of ROM's U6, U7, U23, and U24.

The Free-Run Check is now complete.

7. Turn the analyzer power off.
8. Remove the clip lead from A16TP1 pin 7 and ground.
9. Replace A16U25 (16 pin DIP jumper pack.)
10. Turn the analyzer power on.

## Troubleshooting the IF Section

---

This chapter provides troubleshooting information for the IF section of the HP 8590 E-Series and L-Series spectrum analyzers and HP 8591C cable TV analyzers and HP 8594Q QAM analyzers. Troubleshooting information for tracing signals on the A15 motherboard assembly is also provided.

Refer to Chapter 4 for procedures that are useful when first starting to troubleshoot an analyzer failure.

---

### Before You Start

There are four things you should do before starting to troubleshoot an analyzer failure.

- Check that you are familiar with the safety symbols marked on the analyzer, and read the general safety instructions and the symbol definitions given in the front of this guide.
- The analyzer contains static sensitive components. Read the section entitled “Protection from Electrostatic Discharge” in Chapter 1.
- Become familiar with the organization of the troubleshooting information in this service guide.
- Read the rest of this section.

---

**Warning**     **The analyzer contains potentially hazardous voltages. Refer to the safety symbols on the analyzer and the general safety considerations in the front of this guide before operating the unit with the cover removed. Failure to heed the safety precautions can result in severe or fatal injury.**

---

## **Service equipment you will need**

Refer to the table entitled, “Recommended Test Equipment,” in Chapter 1 of the *HP 8590 Series Analyzers Calibration Guide* for a list of the recommended test equipment needed to troubleshoot and repair the analyzer. Although Hewlett-Packard equipment is recommended, any equipment that meets the critical specifications given in the table can be substituted for the recommended model.

Refer to Chapter 15 of this guide for a list of recommended service tools and required hand tools needed to troubleshoot and repair the analyzer.

## **After an analyzer repair**

If one or more analyzer assemblies have been repaired or replaced, perform the related adjustments and performance verification tests. Refer to Chapter 2 for a table of Adjustments and Tests for Replaced or Repaired Assemblies, for the related adjustments and performance verification tests required for each assembly.

---

## **IF Section Information**

This section provides the control details for the assemblies in the IF section. The control-line outputs are valid when the instrument settings provided with each table are used.

For many IF functions, the A7 analog interface assembly converts the digital control signals from the A16 processor/video assembly to analog control signals. Some analyzer functions are performed directly by the A16 assembly. The A16 assembly also makes amplitude error corrections to improve instrument performance. The analyzer-setting changes and error-correction functions performed on the A16 assembly are a combined mathematical offset of the digitized video signal.

For more information about the A15 motherboard assembly and the tracing of specific signals in the IF section, refer to “A15 motherboard assembly” in this chapter.

---

## IF Power-Level Measurement

The following measurement procedures are used for troubleshooting along the 21.4 MHz IF signal path from the A9 third converter assembly, through the IF section, to output of the A14 log amplifier assembly.

To calibrate the reference level of the analyzer, the **CAL AMPTD** self-calibration routine adjusts the gain of the 21.4 MHz IF variable amplifier on the A9 assembly and mathematically offsets the digitized video signal on the A16 processor/video assembly. Due to component variations it is unlikely that any two analyzers will have the same 21.4 MHz IF signal level for the same instrument settings. Furthermore, a defective analyzer may produce misleading IF signal levels if the **CAL AMPTD** routine has been run.

An IF test board is used in the following procedures to simplify troubleshooting. The test board is used to isolate the RF section from the IF section and allows the testing of individual IF assemblies. Refer to Chapter 15 for the part number of the IF test board.

### To set up the instrument for an IF power-level measurement

The power levels provided with the measurement procedures in this section are accurate when the following steps are followed.

1. Ensure that the CAL OUT amplitude is within specification. Refer to the calibrator amplitude performance test in the *HP 8590 E-Series and L-Series Spectrum Analyzers User's Guide* or *HP 8591C Cable TV Analyzer User's Guide, Spectrum Analyzer Reference*.
2. Connect the CAL OUT signal to the RF input using the CAL cable.
3. Press **PRESET** on the analyzer, then wait for the preset routine to finish. Set the analyzer by pressing the following keys.

**FREQUENCY** 300 **MHz**  
**SPAN** 0 **Hz**

### To check the gains for the IF assemblies

The overall gain of individual assemblies in the IF section are listed below. The gain level provided for the A12 assembly is correct only when the analyzer is set as provided in step three, above.

- The A11 bandwidth filter assembly produces 10 dB of gain.
- The A12 amplitude control assembly produces 5 dB of gain.
- The A13 bandwidth filter assembly produces 10 dB of gain.
- A +10 dBm signal at the input of the A14 log amplifier assembly produces a 2 volt signal (VIDEO\_IF) that is equivalent to a top-screen display.

Refer to "IF Section Information" in Chapter 4 for the changes in gain output when the instrument settings are changed from the settings used in this section.

### **To measure the IF signal from the A9 third converter**

Measure the 21.4 MHz IF output from the A9 assembly with the following procedure. Refer to the IF/Control Overall Block Diagram, while performing this procedure.

1. Remove the A11 bandwidth filter assembly.
2. Insert the IF test board in the A11 assembly slot.
3. Measure the 21.4 MHz IF output at J1 on the IF test board using an active probe, with an analyzer attached. (Use of a 50  $\Omega$  analyzer will cause erroneous power-level measurements.)
4. The test limit for the 21.4 MHz IF signal is  $-45 \text{ dBm} \pm 2 \text{ dB}$ . The test board receives the signal at measurement point A on the block diagram.

Note that the variable IF amplifier at the output of the A9 assembly has a gain range of  $-15$  to  $+2 \text{ dB}$ . This level is dependent on the output from the reference level DAC, located on the A7 analog interface assembly, that is adjusted during the **CAL AMPTD** self-calibration routine.

### **To inject a signal at the output of the A11 bandwidth filter assembly**

Inject a 21.4 MHz signal at the output of the A11 bandwidth filter assembly with the following procedure. Refer to Foldout 9-1 while performing this procedure.

1. Remove the A11 bandwidth filter assembly.
2. Insert the IF test board in the A11 assembly slot.
3. Connect a synthesizer/level generator to the J2 input connector on the IF test board. The test board injects the signal at A15J8 pin 22.
4. Set the signal source for 21.4 MHz at  $+4 \text{ dBm}$ . This signal level provides  $+10 \text{ dBm}$  at the input to the A14 log amplifier assembly and simulates a top-screen signal.
5. Check for the following nominal signal outputs.
  - A  $-10 \text{ dBm}$  at the AUX IF OUTPUT connector on the rear panel. Refer to measurement point C on Foldout 9-1.  
Use an active probe to make the measurement. If a 50  $\Omega$  analyzer is used, an additional 6 dB drop in signal level results. (The AUX IF OUTPUT has a 50  $\Omega$  output impedance.)
  - One volt at the AUX VIDEO OUTPUT connector on the rear panel (measurement point B). A voltage divider on the A15 motherboard reduces the uncorrected 2 volt video signal (AUX\_VIDEO) to a 1 volt output.
  - A signal at the top graticule line and a marker reading of approximately 0 dBm.

Use **CORRECT ON OFF** to observe the magnitude of video offsets that the A16 assembly is currently using to correct the signal position at top-screen. Refer to Chapter 13 for more information about **CORRECT ON OFF**.



## To inject a signal at the output of the A13 bandwidth filter assembly

Inject a 21.4 MHz signal at the output of the A13 bandwidth filter assembly with the following procedure. Refer to Foldout 9-1 while performing this procedure.

1. Remove the A13 bandwidth filter assembly.
2. Insert the IF test board in the A13 assembly slot.
3. Connect a synthesizer/level generator to the J2 input connector on the IF test board. The test board injects the signal at A15J11 pin 22.
4. Set the signal source for 21.4 MHz at +13 dBm. This signal level provides +10 dBm at the input to the A14 log amplifier assembly and simulates a signal at top-screen. The output impedance of the IF test board interacts with circuitry on the A15 assembly to cause a 3 dB signal loss.
5. Check for the following nominal signal outputs.
  - A -10 dBm at the AUX IF OUTPUT connector on the rear panel. Refer to measurement point C on Foldout 9-1.  
Use an active probe to make the measurement. If a 50  $\Omega$  analyzer is used, an additional 6 dB drop in signal level results. (The AUX IF OUTPUT has a 50  $\Omega$  output impedance.)
  - One Volt at the AUX VIDEO OUTPUT connector on the rear panel (measurement point B). A voltage divider on the A15 Motherboard reduces the uncorrected 2 V video signal (AUX\_VIDEO) to a 1 V output.
  - A signal at the top graticule line and a marker reading of approximately 0 dBm.

Use **CORRECT ON OFF** to observe the magnitude of video offsets that the A16 assembly is currently using to correct the signal position at top-screen. Refer to Chapter 13 for more information about **CORRECT ON OFF**.

## To check bandwidth control lines for the A11/A13 bandwidth filter assemblies

Table 5-1 provides nominal bandwidth control voltages sent to the A11 and A13 bandwidth filter assemblies from the A7 analog interface assembly. A calibrated analyzer produces control voltages similar to the values in Table 5-1. (The values in Table 5-1 were measured while default calibration data was in use.)

- Use the difference in control voltage between bandwidths from the table as a guide for normal bandwidth operation.
- Use an extender board to measure the bandwidth control voltages at the motherboard connector for the A7 assembly or the A11/A13 filter assemblies.
- Refer to “Troubleshooting the A15 Motherboard Assembly” for the location of the control lines for each assembly.

**Table 5-1. Nominal Resolution Bandwidth Control Line Voltages**

Resolution Bandwidth	BW5	BW6	BW7
<b>3 dB</b>			
5 MHz	+14.0	-9.9	+4.4
3 MHz	+14.0	-9.9	+6.4
1 MHz	+14.0	-9.9	+8.5
0.3 MHz	+14.0	-9.9	+9.4
0.1 MHz	+14.0	-9.9	+9.7
30 kHz	-1.0	+9.25	+9.7
10 kHz	-1.0	+8.96	+9.7
3 kHz	-1.0	+8.51	+9.7
1 kHz	-1.0	+7.5	+9.7
0.3 kHz	-1.0	+6.0	+9.7
<b>6 dB EMI</b>			
9 kHz	-1.0	+8.81	+9.7
120 kHz	+14.0	-9.9	+9.6

## To check IF section gain control

Table 5-2 lists the changes in IF Section gain that alter the displayed signal position when the reference level is changed in increments as small as 1 dB. The control voltages from the A7 analog interface assembly that change the gain of specific IF assemblies are provided in Table 5-3, Table 5-4, and Table 5-5.

When the reference level is changed, the A16 assembly performs two step-gain functions that change the position of the displayed signal. Refer to Table 5-2 for the reference levels where the A16 assembly changes the signal position in increments of 10 dB. When a reference-level change of less than 1 dB is required, the A16 assembly makes a corresponding change in the signal position. These changes in signal position are made by mathematically offsetting the digitized video signal on the A16 assembly.

The A16 assembly also makes amplitude error corrections to improve instrument performance. The reference-level changes and error-correction functions are a combined mathematical offset of the digitized video signal. This makes it difficult to distinguish which offset is contributing to a change in displayed signal level when the reference level is changed. Disable the error corrections by setting **CORRECT ON OFF** to OFF.

Refer to “Troubleshooting the A15 Motherboard Assembly” in this chapter when tracing control lines in the IF section.

The entries in Table 5-2 are valid after pressing the following keys.

**PRESET**

**CAL**

**More 1 of 3**

**CORRECT ON OFF (OFF)**

Be sure that the input attenuator setting remains at 10 dB.

**Table 5-2. IF Section Gain Table in dB**

Reference Level (dBm) *	A12 Calibration Attenuator (Log/Linear Mode)	A12 Step Gain †	A14 Gain (Linear Mode)	A16 Video Offset (Log Mode) ‡	A16 Video Offset (Linear Mode) ‡
0	10	0	0	0	0
-1	9	0	0	0	0
-2	8	0	0	0	0
-3	7	0	0	0	0
-4	6	0	0	0	0
-5	5	0	0	0	0
-6	4	0	0	0	0
-7	3	0	0	0	0
-8	2	0	0	0	0
-9	1	0	0	0	0
-10	10	10	0	0	0
-20	10	20	0	0	0
-30	10	30	0	0	0
-40	10	40	0	0	0
-50	10	50	0	0	0
-60	10	50	10	10	0
-70	10	50	20	20	0
-80	10	50	30	30	0
-90	10	50	40	40	0
-100	10	50	40	50	10
-110	10	50	40	60	20
-120	10	50	40	70	30
-130	10	50	40	80	40
-131	9	50	40	80	40
-132	8	50	40	80	40
-133	7	50	40	80	40
-134	6	50	40	80	40
-135	5	50	40	80	40
-136	4	50	40	80	40
-137	3	50	40	80	40
-138	2	50	40	80	40
-139	1	50	40	80	40

\* For instruments with 75 Ω Input Impedance, change the display units to dBmV.  
 † The gain of the 10 dB step-gain stage is 15 dB when enabled and 5 dB when disabled.  
 ‡ Turn **CORRECT ON OFF** off to remove the amplitude error corrections generated by **CAL AMPTD**.

## Control lines for the A12 amplitude control assembly

Table 5-3 and Table 5-4 provide the control line output from the A7 analog interface assembly that change the gain of the A12 assembly when the reference level is changed. The calibration attenuator settings in Table 5-4 provide reference-level changes in 1 dB increments for the full reference-level range of the analyzer.

Refer to “Troubleshooting the A15 Motherboard Assembly” in this chapter when tracing control lines in the IF section. The entries in Table 5-3 and Table 5-4 are valid after pressing the following keys.

PRESET

CAL

More 1 of 3

CORRECT ON OFF (OFF)

Be sure that the input attenuator setting remains at 10 dB.

**Table 5-3. 10 dB Step-Gain Control Lines**

Reference Level (dBm)	10 dB Step Gains	IFG1 (10 dB Step) A12J2-14	IFG2 (20-1 dB Step) A12J2-13	IFG3 (20-2 dB Step) A12J2-12
0	0	L	L	L
-10	10	H	L	L
-20	20	L	H	L
-30	30	H	H	L
-40	40	L	H	H
-50	50	H	H	H

H = >2.5 V (TTL High)  
L = <0.8 V (TTL Low)

For each reference level in Table 5-3, the Calibration Attenuator control lines are set to 10 dB of attenuation as shown in the first entry of Table 5-4. The control line settings from Table 5-4 repeat, starting with each reference level in Table 5-3 to produce reference-level changes in 1 dB increments.

**Table 5-4. Calibration-Attenuator Control Lines**

Reference Level (dBm)	Calibration Attenuator	IFA1 (1 dB) A12J2-4	IFA2 (2 dB) A12J2-3	IFA3 (4 dB) A12J2-2	IFA4 (8 dB) A12J2-1	IFA5 (16 dB) A12J2-11
0	10	L	H	L	H	L
-1	9	H	L	L	H	L
-2	8	L	L	L	H	L
-3	7	H	H	H	L	L
-4	6	L	H	H	L	L
-5	5	H	L	H	L	L
-6	4	L	L	H	L	L
-7	3	H	H	L	L	L
-8	2	L	H	L	L	L
-9	1	H	L	L	L	L

H = >2.5 V (TTL High)  
L = <0.8 V (TTL Low)

## To check linear gain control lines for the A14 log amplifier

Table 5-5 provides the control line voltages from the A7 analog interface assembly to the A14 log amplifier assembly. When the analyzer is in linear mode, the seven A14 log amplifier stages are biased to operate as linear amplifiers. Four of the seven stages are also used to provide 40 dB of gain in 10 dB increments. The linear gains are enabled for the reference levels indicated in Table 5-2 and Table 5-5. Two of the four stages operate as one 20 dB amplifier and are controlled by the same control line, IFG6.

Refer to “Troubleshooting the A15 Motherboard Assembly” in this chapter when tracing control lines in the IF section.

When enabled, each control line has a  $-7.6$  Vdc output. This voltage is supplied by the  $-8$  VT temperature-compensated power supply located on the A14 assembly.

The entries in Table 5-5 are valid when the instrument is set up as follows:

PRESET

SCALE LOG LIN LIN

AMPTD UNITS dBm

CAL

More 1 of 3

CORRECT ON OFF (OFF)

**Table 5-5. Linear Gain Control Lines on the A14 Assembly**

Reference Level (dBm)	A14 Gain in Linear Mode (dB)	IFG4 (10-1 dB Step) A14P1-38	IFG5 (10-2 dB Step) A14P1-39	IFG6 (20 dB Step) A14P1-40
-50	0	H	H	H
-60	10	L	H	H
-70	20	L	L	H
-80	30	L	H	L
-90	40	L	L	L

H = +14.3 Vdc (disabled)  
L = -7.6 Vdc (enabled)

---

## Troubleshooting the A15 Motherboard Assembly

Use this section to identify and locate all the signals and voltages that pass through the A15 motherboard assembly. The location of active components on the motherboard are also provided.

The following information is provided in this section.

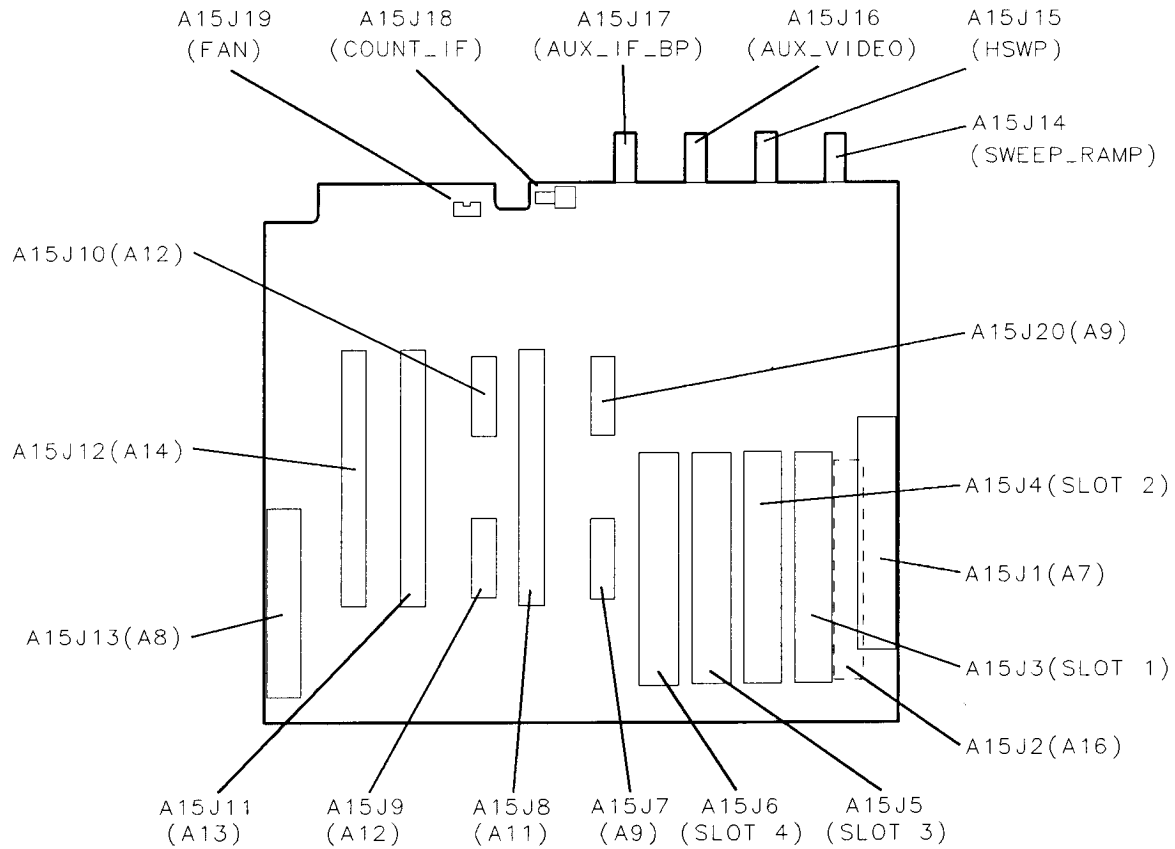
- Figure 5-1, A15 Motherboard Connector Designation. Shows the location and reference designator for each connector on the motherboard.
- Figure 5-2, A15 Connectors with Additional Associated Circuitry. Provides a simplified circuit diagram for the components on the motherboard. To help locate the components, the motherboard connector-pin that is connected to each component is shown.
- Figure 5-3, A15J13 Connector-Pin Designation. Provides the pin numbering sequence for the connector that connects the A8 power supply to the motherboard.
- Figure 5-4, Card-Cage Connector Pin Designation. Provides the pin-numbering sequence for the four motherboard connectors in the card cage. The motherboard connector for the A7 analog interface assembly (not shown) has the same pin-numbering sequence, but is installed in a position that is reversed when compared to the card-cage connectors.
- Table 5-6, A15 Motherboard Mnemonic Descriptions. Provides the mnemonic, full name, and functional description for each signal and voltage on the motherboard.
- Table 5-7, A15 Motherboard Pin Designations. Identifies the signal or voltage distribution for each signal and voltage on the motherboard.

Each column identifies the instrument assembly that is connected to the A15 motherboard. The associated motherboard reference designator for each assembly is also supplied.

The mnemonics from Table 5-7 are arranged alphabetically by row on the left-hand side of the table.

For a given mnemonic, read across the row to find all the assemblies that the signal or voltage is connected to. The A15 connector pin numbers in each box indicate the A15 connector pins where the signal or voltage appear.

Be sure to read the footnotes at the bottom of Table 5-7.

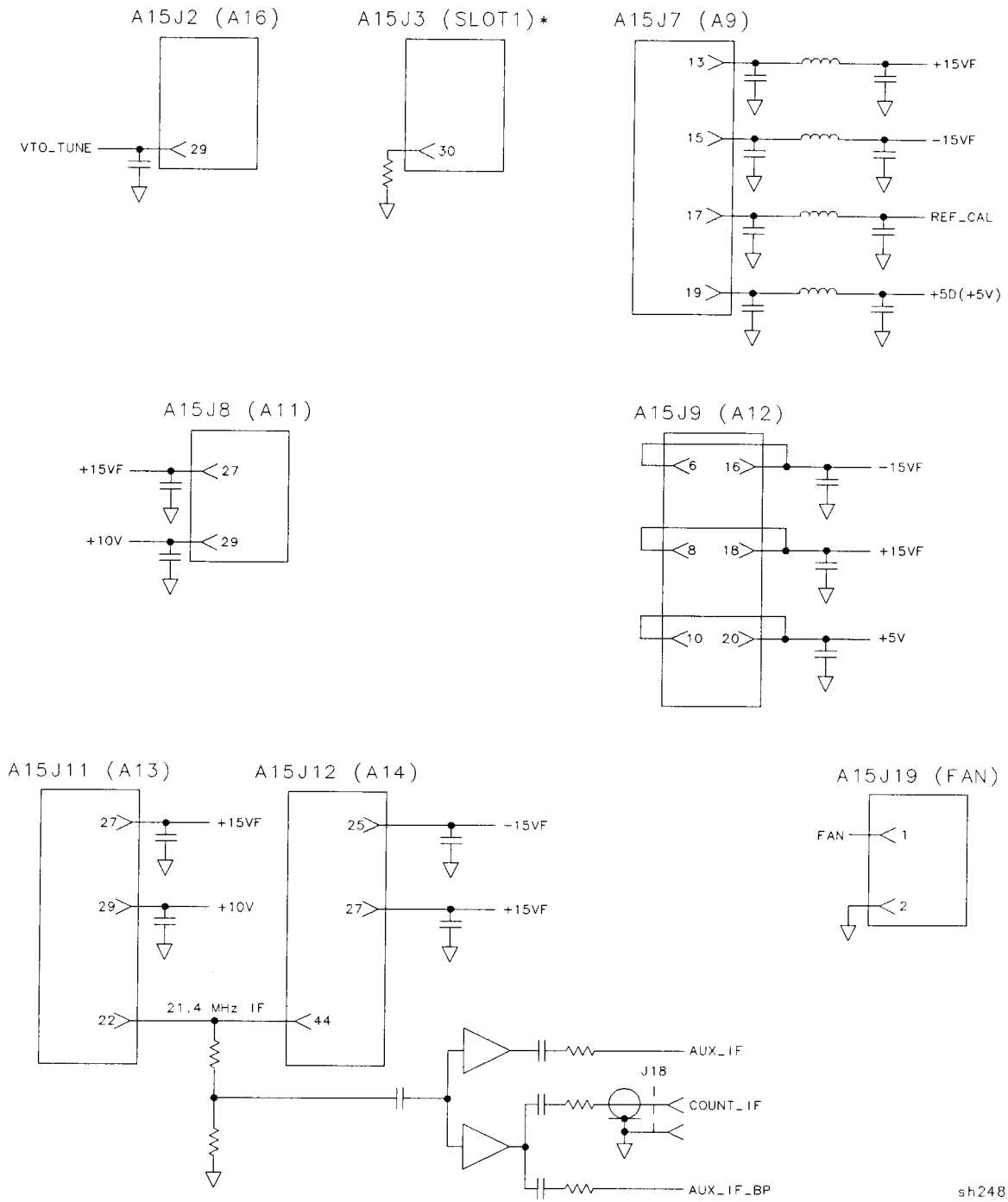


sh247e

**Figure 5-1. A15 Motherboard Connector Designation**

- All connector pins on A9J20 are tied to ground (ACOM).
- The A15J1 connector for the A7 analog interface assembly is installed in a position that is reversed when compared to card-cage connectors A15J3, A15J4, A15J5, and A15J6; therefore, the pin-numbering order is also reversed for A15J1 when compared to the card-cage connectors.

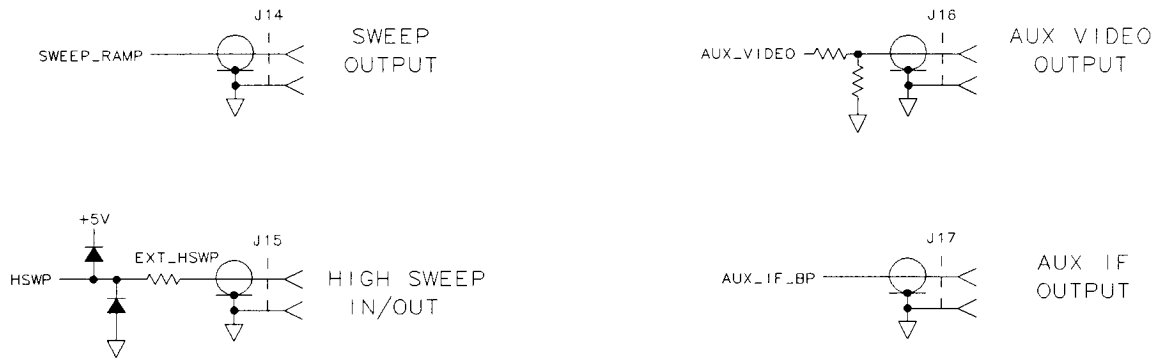




sh248e

**Figure 5-2. A15 Connectors with Additional Associated Circuitry (1 of 2)**

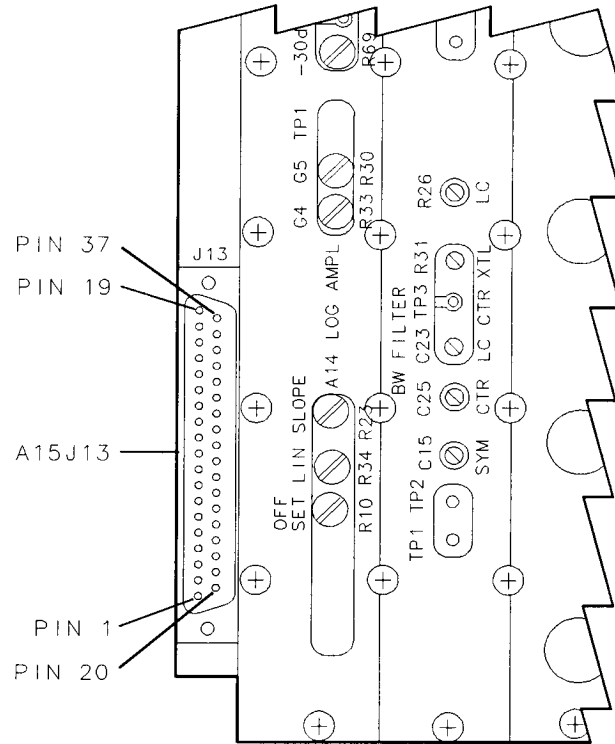
## REAR FRAME CONNECTORS



sh249e

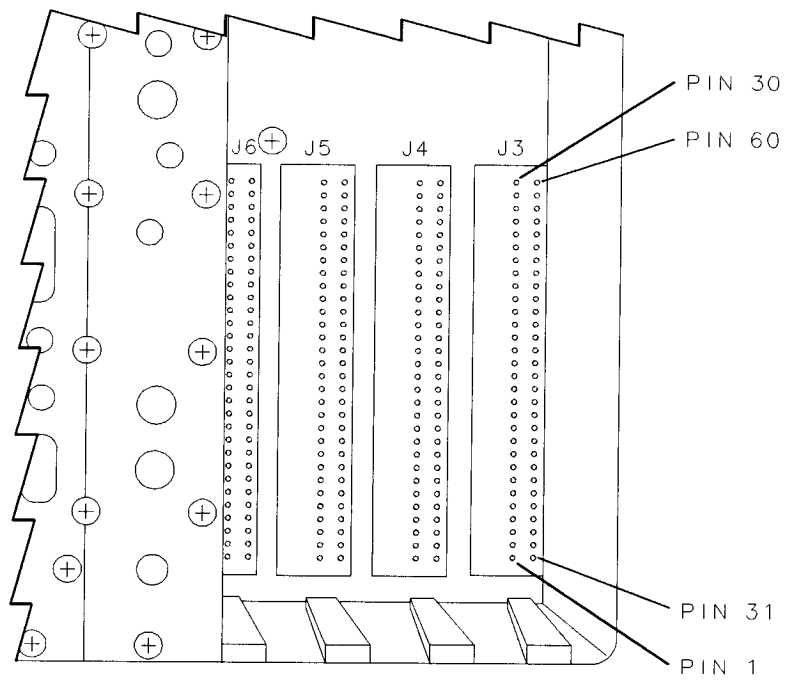
**Figure 5-2. A15 Connectors with Additional Associated Circuitry (2 of 2)**

- The A15 motherboard pin designation for the 21.4 MHz IF signal path is provided in Table 5-7.
- All the connector pins with the same number are connected in parallel for the card-cage connectors A15J3, A15J4, A15J5, and A15J6.



sh250e

**Figure 5-3. A15J13 Connector-Pin Designation**



sh268e

**Figure 5-4. Card-Cage Connector Pin Designation**

**Table 5-6. A15 Motherboard Mnemonic Descriptions**

<b>Mnemonic</b>	<b>Full Name</b>	<b>Description</b>
21.4 MHz IF	21.4 MHz IF	The 21.4 MHz IF signal between the A9 Third Converter assembly and the detector on the A14 Log Amplifier assembly.
+10V	+10 V Supply	The A7 Analog assembly provides a +10 V bias supply for the LC bandwidth filters on the A11/A13 bandwidth filter assemblies.
+12V	+12 V Supply	+12 V supply for the A2 Display and the RS-232 option, referenced to DCOM.
+15VF	+15 V Supply	+15 V power supply, referenced to ACOM.
+5V	+5 V Supply	+5 V power supply, referenced to DCOM.
-15V	-15 V Supply	-15 V power supply, referenced to ACOM.
-8VT	-8 V Temperature Compensated Supply	Provides -8 V from the temperature-compensated (TC) power supply on the A14 Log Amplifier assembly to the A7 Analog Interface assembly. The A7 provides temperature-compensation for the IFG4-IFG6 and the Log/Lin control lines using the -8 VT as a TC reference.
ACOM	Analog Common	A common ground for all analog circuitry.
ADC_SYNC	A/D Conversion Synchronization	A positive-going signal that indicates when the main ADC on the A16 Video/Processor assembly has started an A/D conversion. ADC_SYNC resets the peak detectors located on assemblies installed in the HP 8590L, HP 8591C, HP 8591E, HP 8593E, HP 8594E, HP 8595E, HP 8596E, and HP 8594Q card cage.
ADR0-ADR4	Address 0-4	Input/Output (IO) address lines.
ANA_TEST	Analog Test	Provides a series of test signals from A7 Analog Interface assembly to A16 Processor/Video assembly during instrument calibration and troubleshooting. (Refer to the A7 Overview Section)
AUX_IF	Auxiliary IF	An uncorrected, buffered 21.4 MHz IF signal from the output of the A13 bandwidth filter assembly to the four card-cage slots.
AUX_IF_BP	Auxiliary IF Back Panel	An uncorrected, buffered 21.4 MHz IF signal from the output of the A13 bandwidth filter assembly to J17, AUX IF OUTPUT.
AUX_VIDEO	Auxiliary Video	A detected video signal (0–2 V) that has passed through the video filters. No amplitude corrections have been applied to this signal. A voltage divider at J16, AUX VIDEO OUTPUT, reduces the signal amplitude to 0–1 V.

**Table 5-6. A15 Motherboard Mnemonic Descriptions (continued)**

Mnemonic	Full Name	Description
BW5	Bandwidth 5	A bias voltage that activates either the LC or crystal bandwidth-filter mode.
BW6	Bandwidth 6	Controls the crystal-filter bandwidth.
BW7	Bandwidth 7	Controls the LC filter bandwidth.
COUNT_IF	Counterlock IF	A buffered 21.4 MHz IF signal from the output of the A13 bandwidth filter assembly to A25 Counter-Lock assembly.
CRD_ANLG_1	Card Cage Analog 1	An analog signal from assemblies installed in the card cage to the A16 input multiplexer. When it is selected, the signal passes through the A16 video-filter and peak-detector sections. It is available on AUX_VIDEO after it passes through the video filter.
CRD_ANLG_2	Card Cage Analog 2	An analog signal from assemblies installed in the card cage. The signal goes directly to A16 A/D conversion section, bypassing both the video-filter and peak-detector sections.
DCOM	Digital Common	A common ground for all digital circuitry.
DISCRIM or DISCRIMINATOR	Discriminator	For Spans $\leq 10$ MHz, the A25 Counter-Lock assembly sends a dc tuning voltage through the A16 Processor/Video assembly to the A7 Analog Interface assembly. The A7 assembly then adjusts the YTO to reduce residual FM.
EXT_HSWP	External High Sweep	EXT_HSWP performs two functions: 1) It provides external control of high sweep on the A16 Processor/Video when an external signal is connected to J15, HIGH SWEEP INPUT/OUTPUT. 2) It provides the HSWP signal as a rear-panel output at J15, HIGH SWEEP INPUT/OUTPUT. <i>This is an open-collector signal. It should never be driven high.</i>
FAN	FAN	+ 12 V power supply for the B1 fan.
HPWRUP	High Power Up	Enables the initial start-up sequence for the CPU on the A16 Processor/Video assembly when the analyzer is first turned on. This occurs prior to the start-up of other related assemblies.
HSWP	High Sweep	Provides control for the analyzer display sweep and retrace. A TTL high starts a sweep and a TTL low initiates a retrace. <i>This is an open-collector signal. It should never be driven high.</i>

**Table 5-6. A15 Motherboard Mnemonic Descriptions (continued)**

<b>Mnemonic</b>	<b>Full Name</b>	<b>Description</b>
IFA1	IF Attenuation 1	Control line for 1dB step attenuator on the A12 Amplitude Control assembly.
IFA2	IF Attenuation 2	Control line for the 2 dB step attenuator on the A12 Amplitude Control assembly.
IFA3	IF Attenuation 3	Control line for the 4 dB step attenuator on the A12 Amplitude Control assembly.
IFA4	IF Attenuation 4	Control line for the 8 dB step attenuator on the A12 Amplitude Control assembly.
IFA5	IF Attenuation 5	Control line for the 16 dB step attenuator on the A12 Amplitude Control assembly.
IFG1	IF Gain 1	Control line for the 10 dB step gain on the A12 Amplitude Control assembly.
IFG2	IF Gain 2	Control line for the first 20 dB step gain on the A12 Amplitude Control assembly.
IFG3	IF Gain 3	Control line for the second 20 dB step gain on the A12 Amplitude Control assembly.
IFG4	IF Gain 4	Temperature-compensated control line for the 10 dB linear gain on the A14 Log Amplifier assembly.
IFG5	IF Gain 5	Temperature-compensated control line for the 10 dB linear gain on the A14 Log Amplifier assembly.
IFG6	IF Gain 6	Temperature-compensated control line for the 20 dB linear gain on the A14 Log Amplifier assembly.
INTERBUS	Interbus	A communication line between the four slots in the card cage. It coordinates functions between options when more than one option is installed in the card cage.
IOB0-IOB15	Input/Output Bus 0-Input/Output Bus 15	Input/Output (IO) data lines used between the A16 Processor/Video assembly and related assemblies.
LBIO	Low Bottom-box Input/Output	Strobe line for Input/Output (IO) data transfers.
LINE_TRIG	Line Trigger	Provides a TTL signal at the power-line frequency rate. It enables the line-trigger mode on the A16 Processor/Video assembly.
LOG_LIN	Log Linear	Controls switching between log and linear modes on the A14 Log Amplifier assembly.

**Table 5-6. A15 Motherboard Mnemonic Descriptions (continued)**

<b>Mnemonic</b>	<b>Full Name</b>	<b>Description</b>
LPWRON	Low Power On	The front-panel line switch provides a TTL low when the switch is depressed. This initiates start-up of the A8 Power Supply and A16 Processor/Video assemblies.
LTIO	Low Top-box Input/Output	Strobe line for Input/Output (I/O) data transfers.
REF_CAL	Reference Cal	A DAC on the A7 Analog Interface assembly adjusts the gain of the A9 Third Converter assembly through REF_CAL.
SWEEP_RAMP	Sweep Ramp	A 0 to +10 V ramp signal that corresponds to signal sweep across the display. The signal is sent to J14, SWEEP OUTPUT, on the rear frame.
VIDEO_IF	Video IF	The detected 21.4 MHz IF signal from the detector on the A14 Log Amplifier assembly to the input multiplexer on the A16 Processor/Video assembly.
VTO_TUNE	Voltage-Tuned Oscillator Tune	A tuning voltage from the A25 Counter-Lock assembly to A9 Third Converter assembly. It locks the 600 MHz oscillator on the A9 assembly to the frequency reference.



**Table 5-7. A15 Motherboard Pin Designations**

Mnemonic	Instrument Assemblies									Card Cages *
	A7	A8	A9	A11	A12		A13	A14	A16	Slots 1, 2, 3, 4
	A15J1	A15J13	A15J7	A15J8	A15J9	A15J10	A15J11	A15J12	A15J2	A15J3, 4, 5, 6
21.4 MHz IF			9	22, 23	1	20	22, 23 †	44 †		
+ 10 V	22 †			29			29 †			
+ 12 V		13, 32							27, 57	
+ 15 V	3, 33	1, 2, 3, 20, 21, 22 †	‡	27 †	8, 18		27 †	27 †	8, 38	9, 39
+ 5 V	19, 49	9, 10, 11, 12, 28, 29, 30, 31 †	‡		10, 20				25, 26, 55, 56	26, 56
- 15 V	4, 34	4, 5, 6, 23, 24, 25 †	‡		6, 16 †			25 †	9, 39	10, 40
- 8 VT	23							8 †		
ACOM	2, 32	7, 26, 27	1-8, 10, 12, 14, 16, 18, 20	1-21, 24-26, 28, 33-44	2-5, 7, 9, 11-15, 17, 19	5-10, 15-19	1-21, 24-26, 28, 33-44	1, 3-7, 9-24, 26, 28-30, 32-37, 41-43	2, 4, 6, 32-37	2, 4, 6, 8, 29, 31-38, 59, 60
ADC_SYNC									30 †	27
ADR0	6								11 †	12
ADR1	36								41 †	42
ADR2	7								12 †	13
ADR3	37								42 †	43
ADR4	8								13 †	14
ANA_TEST	31								31 †	
AUX_IF							22 † ‡			30
AUX_IF_BP							22 † ‡			
AUX_VIDEO †									7 †	7
BW5	24 †			30			30			
BW6	54 †			31			31			
BW7	25 †			32			32			
COUNT_IF †										
CRD_ANLG_1									3 †	3
CRD_ANLG_2									5 †	5
DCOM	11, 16, 35, 38, 43, 48	14-17, 33-36							16, 21, 40, 43, 48, 53	17, 22, 41, 44, 49, 54

\* HP 8590 E-Series, HP 8591C and HP 8594Q only.

† Pin numbers indicate assembly where signal or voltage originates.

‡ Refer to the figure, "A15 Connectors with Additional Associated Circuitry" in this section.

**Table 5-7. A15 Motherboard Pin Designations (continued)**

Mnemonic	Instrument Assemblies									Card Cages *
	A7	A8	A9	A11	A12		A13	A14	A16	Slots 1, 2, 3, 4 A15J3, 4, 5, 6
	A15J1	A15J13	A15J7	A15J8	A15J9	A15J10	A15J11	A15J12	A15J2	
DISCRIMINATOR	21								28 †	
EXT_HSWP ‡										
FAN †		8 †								
HPWRUP	50	37 †							54	55
HSWP †									58 †	57
IFA1	58 †					4				
IFA2	29 †					3				
IFA3	59 †					2				
IFA4	30 †					1				
IFA5	60 †					11				
IFG1	55 †					14				
IFG2	26 †					13				
IFG3	56 †					12				
IFG4	27 †							38		
IFG5	57 †							39		
IFG6	28 †							40		
INTERBUS										58 †
IOB0	9								14	15
IOB1	39								44	45
IOB2	10								5	16
IOB3	40								45	46
IOB4	41								46	47
IOB5	12								17	18
IOB6	42								47	48
IOB7	13								18	19
IOB8	14								19	20
IOB9	44								49	50
IOB10	15								20	21
IOB11	45								50	51
IOB12	46								51	52
IOB13	17								22	23
IOB14	47								52	53
IOB15	18								23	24

\* HP 8590 E-Series, HP 8591C and HP 8594Q only.  
† Pin numbers indicate assembly where signal or voltage originates.  
‡ Refer to the figure, "A15 Connectors with Additional Associated Circuitry" in this section.

**Table 5-7. A15 Motherboard Pin Designations (continued)**

Mnemonic	Instrument Assemblies									Card Cages *
	A7 A15J1	A8 A15J13	A9 A15J7	A11 A15J8	A12 A15J9   A15J10		A13 A15J11	A14 A15J12	A16 A15J2	Slots 1, 2, 3, 4 A15J3, 4, 5, 6
LBIO	5								10 †	11
LINE_TRIG		18 †							60	
LOG_LIN	52 †							31		
LPWRON		19							59 †	
LTIO									24 †	25
REF_CAL	53 †		‡							
SWEEP_RAMP ‡	51 †									28
VIDEO_IF								2 †	1	1
VTO_TUNE			11						29 † ‡	

\* HP 8590 E-Series, HP 8591C and HP 8594Q only.  
† Pin numbers indicate assembly where signal or voltage originates.  
‡ Refer to the figure, "A15 Connectors with Additional Associated Circuitry" in this section.

## Troubleshooting the RF Section

---

This chapter provides troubleshooting information for the RF section of the HP 8590 E-Series and L-Series spectrum analyzers, HP 8591C cable TV analyzers, and HP 8594Q QAM analyzers. This chapter is divided into two sections.

Chapter 6a describes troubleshooting information for the HP 8590L and HP 8591E spectrum analyzers and HP 8591C cable TV analyzers.

Chapter 6b describes troubleshooting information for the HP 8592L, HP 8593E, HP 8594E, HP 8594L, HP 8595E, and HP 8596E spectrum analyzers and HP 8594Q QAM analyzer.

Refer to Chapter 4 for troubleshooting procedures that are useful when first starting to troubleshoot an analyzer failure.

---

### Before You Start

There are four things you should do before starting to troubleshoot an analyzer failure:

- Check that you are familiar with the safety symbols marked on the analyzer, and read the general safety considerations and the safety note definitions given in the front of this guide.
- The analyzer contains static-sensitive components. Read the section entitled, "Protection From Electrostatic Discharge" in Chapter 1.
- Become familiar with the organization of the troubleshooting information in this service guide.
- Read the rest of this section.

---

**Warning**     **The analyzer contains potentially hazardous voltages. Refer to the safety symbols on the analyzer and the general safety considerations in this manual before operating the unit with the cover removed. Failure to heed the safety precautions can result in severe or fatal injury.**

---

## **Service equipment you will need**

Refer to the table entitled, "Recommended Test Equipment," in Chapter 1 of the *HP 8590 Series Analyzers Calibration Guide* for a list of the recommended test equipment needed to troubleshoot and repair the analyzer. Although Hewlett-Packard equipment is recommended, any equipment that meets the critical specifications given in the table can be substituted for the recommended model.

Refer to Chapter 15 of this guide for a list of recommended service tools and required hand tools needed to troubleshoot and repair the analyzer.

## **After an analyzer repair**

If one or more analyzer assemblies have been repaired or replaced, perform the related adjustments and performance verification tests. Refer to Chapter 2 for a table of Adjustments and Tests for Replaced or Repaired Assemblies, for the related adjustments and performance verification tests required for each assembly.

## HP 8590L, HP 8591C, and HP 8591E

This section describes the RF section troubleshooting process for the HP 8590L and HP 8591E spectrum analyzers and HP 8591C cable TV analyzers.

### Making RF Power-Level Measurements

The power level ranges listed for measurements A through G in Table 6-1 apply after performing the following steps:

1. Connect the CAL OUT to the RF INPUT using the CAL cable.  
Ensure that the CAL OUT amplitude is within specification. (Refer to the calibrator amplitude performance test in the calibration guide.)
2. Perform the frequency and amplitude calibration routines.
3. Press **PRESET**, then wait for the analyzer to complete the preset routine.
4. Press the following instrument keys:

**FREQUENCY** 300 **MHz**  
**SPAN** 0 **Hz**

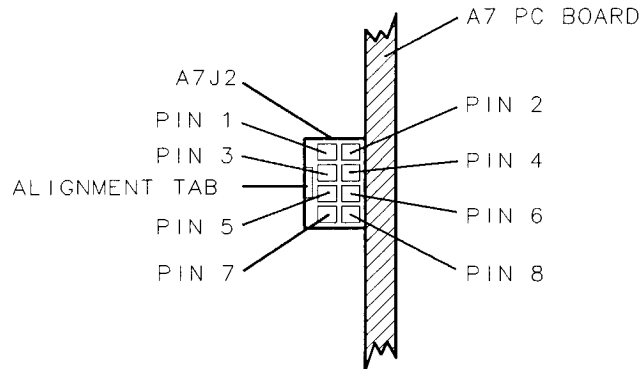
**Table 6a-1. Power Levels at Measurement Points**

Measurement Point	Measurement Frequency	Power Level Range * (dBm)	
		50 $\Omega$	75 $\Omega$
A	300 MHz	-29 to -31	-35 to -37
B	2.1214 GHz	-39 to -43	-46 to -49
C	2.1214 GHz	-39 to -44	-46 to -50
D	321.4 MHz	-42 to -46	-51 to -55
E	2.4214 GHz	+6 to +12	Same as 50 $\Omega$
F	2.4214 GHz	-10 to -20	Same as 50 $\Omega$
G	1.8 GHz	-17 to -23	Same as 50 $\Omega$

\* A frequency-selective measuring device, such as another analyzer, is recommended for making these measurements. Broadband measuring devices, such as power meters, give erroneous results due to the presence of other, higher-amplitude signals.

## Connector Pin-Out Information

The RF section receives control voltages for the A3 attenuator from the A7 analog interface assembly. It also receives power-supply voltages for the A3 attenuator and A5 second converter assemblies from the A7 analog interface assembly. The W13 wire harness connects the attenuator and second converter to the A7J2 connector on the A7 assembly. Table 6-2 identifies the signals that are supplied to the two RF assemblies and Figure 6-1 shows the pin number location on A7J2.



sh2104e

**Figure 6a-1. A7J2 Pin-Out**

**Table 6a-2. A7J2 Connector Pin Designation (Top-Side View)**

A7J2 Pin Number	W13 Wire Color	Signal Description
1	Brown	+ 8 VF power supply for A5 Second Converter
2	Black	Analog ground for A5 Second Converter
3	Orange	+ 15 VF power supply for A3 Attenuator
4	N/C	
5	Green	Control line for 20 dB step on A3 Input Attenuator
6	Blue	Control line for 10 dB step on A3 Input Attenuator
7	N/C	
8	Grey	Control line for 30 dB step on A3 Input Attenuator

## To check control of the A3 input attenuator

The A7 analog interface assembly controls the three attenuator steps in the A3 input attenuator. Each attenuator step requires one control line, as shown in Table 6a-3. The W13 wire harness connects the attenuator to A7J2 on the A7 assembly. W13 also supplies the +15 V power supply for the attenuator. Locate W13 using the top view of the analyzer in Chapter 11.

Use a digital multimeter (DMM) and the values from Table 6a-3 to check the control voltages for each attenuator step. Refer to Figure 6-1 for the location of the connector pins on A7J2. Measure the voltages at the A7J2 pins on the trace side of the A7 assembly.

**Table 6a-3. Input Attenuator Control Output at A7J2**

Attenuator Setting (dB)	10 dB Step (A7J2 Pin 6)	20 dB Step (A7J2 Pin 5)	30 dB Step (A7J2 Pin 8)
0	L	L	L
10	H	L	L
20	L	H	L
30	H	H	L
40	H	L	H
50	L	H	H
60	H	H	H

H = +15 V (A high output indicates that the attenuator step is in the signal path.)  
L = +0.8 V

These control voltages are valid only if the A3 Input Attenuator is connected to A7J2.



## HP 8592L/94L, HP 8594Q, and HP 8593E/94E/95E/96E

---

This section describes the RF section troubleshooting process for the HP 8592L, HP 8593E, HP 8594E, HP 8594L, HP 8595E, and HP 8596E spectrum analyzers, and HP 8594Q QAM analyzers.

---

### Making RF Power-Level Measurements

The power level ranges listed for measurements A through E in Table 6-4 apply after performing the following steps:

1. Ensure that the CAL OUT amplitude is within specification. (Refer to the calibrator amplitude performance test in the calibration guide.)

2. Select the appropriate input signal for the desired frequency band:

Band 0	.....	300 MHz at -20 dBm (CAL OUT signal)
Band 1	.....	5 GHz at 0 dBm
Band 2	.....	10 GHz at 0 dBm
Band 3	.....	15 GHz at 0 dBm
Band 4	.....	20 GHz at 0 dBm

3. Press **PRESET**, then wait for the analyzer to complete the preset routine.

4. Press the following instrument keys:

**FREQUENCY** (same as input signal)

**SPAN** 0 **Hz**

**AMPLITUDE** 0 **dBm**

**ATTEN** 10 **dB**

**BW** 3 **MHz**

**SWEEP**

**SWEPTIME** 20 **ms**

**Table 6b-1. Power Levels at Measurement Points**

Measurement Point	Measurement Frequency	Power Level Range *				
		Band 0 92L,93E,94E 94L,94Q,95E 96E	Band 1 92L,93E 95E,96E	Band 2 92L,93E,96E	Band 3 92L,93E	Band 4 92L,93E
A	Same as input frequency	-30 to -33 dBm	—	—	—	—
B	Same as input frequency	—	-14 to -19 dBm	-14 to -19 dBm	-14 to -20 dBm	-15 to -23 dBm
C	321.4 MHz	—	10 to 16 dB below B †	18 to 26 dB below B †	21 to 31 dB below B †	25 to 35 dB below B †
D	3.9214 GHz	8 to 12 dB below A †	—	—	—	—
E	321.4 MHz	5 to 11 dB below D †	1 to 6 dB below C †	1 to 6 dB below C †	1 to 6 dB below C †	1 to 6 dB below C †
<p>* A frequency-selective measuring device, such as another analyzer, is recommended for making these measurements. Broadband measuring devices, such as power meters, will give erroneous results due to the presence of other, higher-amplitude signals.</p> <p>† The power-level range is relative to the actual measurement taken at the measurement point indicated.</p>						

## Connector Pin-Out Information

The RF section receives control voltages from the A7 analog interface assembly. It also receives power-supply voltages for the attenuator and second converter assemblies from the A7 analog interface assembly. Tables 6-5 and 6-6 identify the signals that are supplied to the two RF assemblies for both the standard and option 026 spectrum analyzers.

**Table 6b-2.**  
**A7J2 Connector Pin Designation for**  
**HP 8592L, 8593E, 8596E**

A7J2 Pin Number	W13 Wire Color	Signal Description
1	Black	Normally Open
2	Grey	Normally Closed
3	Orange	ACOM
4	Yellow	+ 15 VF
5	Green	POS_MXR_BIAS
6	Blue	PIN_Switch
7	Violet	COMB
8	N/C	
9	White and Red	+ 15 VF
10	N/C	- 15 VF

**Table 6b-3.**  
**A7J2 Connector Pin Designation for Option 026**  
**for HP 8595E**

A7J2 Pin Number	W13 Wire Color	Signal Description
1	Brown	Normally Open
2	Red	Normally Closed
3	N/C	ACOM
4	N/C	+ 15 VF
5	Green	POS_MXR_BIAS
6	Blue	PIN_Switch
7	N/C	COMB
8	N/C	
9	N/C	+ 15 VF
10	N/C	- 15 VF

**Table 6b-4.**  
**A7J4 2nd Converter Drive Pin Designation for**  
**HP 8592L, HP 8593E, HP 8594E, HP 8594L, HP 8594Q, HP 8595E, HP**  
**8596E**

<b>A7J4 Pin Number</b>	<b>Signal Description</b>
1	2nd Mixer Bias
2	+5 A
3	ACOM
4	+10 VF
5	PIN_SW
6	KEY
7	N/C
8	N/C
9	N/C
10	N/C

**Table 6b-5.**  
**A7J301 YTF Driver Pin Designation for**  
**HP 8592L, 8593E, 8595E, 8596E**

<b>A7J301 Pin Number</b>	<b>W34 Wire Color</b>	<b>Signal Description</b>
1	Brown	YIG_FLT+
2	Orange	YIG_FLT-
3	Green	-15 VF
4	Violet	+15 VF

**Table 6b-6.**  
**A10J1 Tracking Generator Control Pin Designation for**  
**HP 8593E, HP 8594E, HP 8594L, HP 8594Q, HP 8595E, HP 8596E**

<b>A10J1 Pin Number</b>	<b>Signal Description</b>
1	+15 VF
2	ACOM
3	-15 VF
4	OSC_PWR
5	TUNE
6	ALC_MON
7	KEY
8	PWR_LVL
9	+5 VF1
10	ALC_EXT

## To check control of the A3A5 input attenuator

The A7 analog interface assembly controls the three attenuator steps and blocking capacitor in the A3A5 input attenuator using eight control lines. Refer to the RF section block diagram for your analyzer at the end of Chapter 9. Each attenuator step requires two control lines, as shown in Tables 6-10 and 6-11. The attenuator is connected to A7J5 on the A7 assembly with the ribbon cable, W36. Locate W36 using the top view of the analyzer in Chapter 11.

Use a digital multimeter (DMM) and the values from Table 6b-7 to check the control voltages. Measure the voltages at the A7J5 pins on the trace side of the A7 assembly.

**Table 6b-7.**  
**Input Attenuator Control Output at A7J5**  
**for HP 8592L and 8593E**

Attenuator Setting (dB)	10 dB Step		1st 20 dB Step		2nd 20 dB Step		3rd 20 dB Step	
	Pin 2	Pin 1	Pin 9	Pin 4	Pin 8	Pin 5	Pin 7	Pin 6
0	H	L	H	L	H	L	H	L
10	L	H	H	L	H	L	H	L
20	H	L	H	L	L	H	H	L
30	L	H	H	L	L	H	H	L
40	H	L	L	H	H	L	L	H
50	L	H	L	H	H	L	L	H
60	H	L	L	H	L	H	L	H
70	L	H	L	H	L	H	L	H

H = -10 V (with the attenuator connected at A7J5)  
H = 0 V (A floating output if the attenuator is disconnected.)  
L = -15 V (A low at pin 2, 9, 8, or 7 indicates that the attenuator step is in the signal path.)

**Table 6b-8.**  
**Input Attenuator Control Output at A7J5**  
**for HP 8594E, HP 8594L, HP 8594Q, HP 8595E, HP 8596E**

Attenuator Setting (dB)	10 dB Step		40 dB Step		20 dB Step		Blocking Capacitor	
	Pin 2	Pin 1	Pin 9	Pin 4	Pin 8	Pin 5	Pin 7	Pin 6
0	H	L	H	L	H	L	—	—
10	L	H	H	L	H	L	—	—
20	H	L	H	L	L	H	—	—
30	L	H	H	L	L	H	—	—
40	H	L	L	H	H	L	—	—
50	L	H	L	H	H	L	—	—
60	H	L	L	H	L	H	—	—
70	L	H	L	H	L	H	—	—
Blocking Capacitor In	—	—	—	—	—	—	L	H
Blocking Capacitor Out	—	—	—	—	—	—	H	L

H = -10 V (with the attenuator connected at A7J5)  
H = 0 V (A floating output if the attenuator is disconnected.)  
L = -15 V (A low at pin 2, 9, or 8 indicates that the attenuator step is in the signal path. A low at pin 7 indicates the blocking capacitor is in the signal path.)

# Replacing Major Assemblies

---

## Introduction

The procedures in this chapter describe the removal and replacement of major assemblies in the HP 8590L, HP 8591C, HP 8591E, HP 8592L, HP 8593E, HP 8594E, HP 8594L, HP 8594Q, HP 8595E, and HP 8596E analyzers.

The words “right” and “left” are used throughout these procedures to indicate the sides of the analyzer as normally viewed from the front of the instrument. Numbers in parentheses, for example (1), indicate numerical callouts on the figures.

---

## Before You Start

There are four things you should do before starting to troubleshoot an analyzer failure:

- Check that you are familiar with the safety symbols marked on the analyzer, and read the general safety considerations and the safety note definitions given in the front of this service guide.
- The analyzer contains static sensitive components. Read the section entitled “Protection from Electrostatic Discharge” in Chapter 1.
- Become familiar with the organization of the troubleshooting information in this service guide.
- Read the rest of this section.

---

**Warning**      **The analyzer contains potentially hazardous voltages. Refer to the safety symbols on the analyzer and the general safety considerations in this guide before operating the unit with the cover removed. Failure to heed the safety precautions can result in severe or fatal injury.**

---

## Service equipment you will need

Refer to Chapter 1 of the *HP 8590 Series Analyzers Calibration Guide* for a list of the recommended test equipment needed to troubleshoot and repair the analyzer. Although Hewlett-Packard equipment is recommended, any equipment that meets the critical specifications given in the table can be substituted for the recommended model.

Refer to Chapter 15 of this guide for a list of required service and hand tools needed to troubleshoot and repair the analyzer.

## **After an analyzer repair**

If one or more analyzer assemblies have been repaired or replaced, perform the related adjustments and performance verification tests. Refer to Chapter 2 for a table of Adjustments and Tests for Replaced or Repaired Assemblies, for the related adjustments and performance verification tests required for each assembly.

---

## **Removal and Replacement Procedures in this Chapter**

Instrument Cover

A1 Front-Frame Assembly

A1A1 Keyboard/Front Panel Keys

A2 Display

RF Assembly

A3 Front-End Assembly

A7 Analog Assembly

A8 Power Supply

A15 Motherboard and IF Extrusion

A16 Processor/Video Board and Firmware

A16A1 Memory Board

A16A1BT1 Battery

A17 Memory Card Reader

A25 Counter-Lock Assembly

B1 Fan

Rear Frame



---

## Instrument Cover

### This procedure applies to:

HP 8590 E-Series and L-Series spectrum analyzers  
HP 8591C cable TV analyzers  
HP 8594Q QAM analyzers

### Removal

1. Disconnect the analyzer from ac power.

---

**Caution** To prevent damage to the front frame, use a soft cloth or towel between the work surface and the front frame.

---

2. Carefully place the analyzer on the worksurface with the front frame facing down.
3. Remove the four screws and washers attaching the instrument cover to the rear frame.
4. Unscrew, but do not remove, the four rear-foot screws, using a 4 mm hex wrench.
5. Pull the instrument cover off towards the rear of the instrument.

### Replacement

1. Disconnect the analyzer from ac power.

---

**Caution** To prevent damage when replacing the instrument cover, remember the following:

- Place a soft cloth or towel between the worksurface and the front frame.
- Ensure that cables do not bind between the instrument cover and its internal assemblies.

---

2. Carefully place the analyzer on the worksurface with the front frame facing down.
3. Replace the instrument cover assembly by matching the seam on the cover with the bottom of the instrument.
4. Fit the leading edge of the cover completely into the slot on the back of the front-frame assembly. The cover should fit snugly against the EMI gasket in the slot.
5. Tighten the four rear-foot screws with a 4-mm hex wrench.
6. Replace the four screws and washers attaching the instrument cover assembly to the rear frame.

---

## A1 Front-Frame Assembly

### This procedure applies to:

HP 8590 E-Series and L-Series spectrum analyzers  
HP 8591C cable TV analyzers  
HP 8594Q QAM analyzers

---

**Caution** Use ESD precautions when performing this replacement procedure.

---

### Removal

1. Remove the instrument cover assembly. Refer to the “Instrument Cover” removal procedure.
2. Place the analyzer with the bottom side facing up on the worksurface.
3. If the instrument came equipped with the A17 Memory Card Reader, remove it. Refer to the “A17 Memory Card Reader” removal procedure.
4. On HP 8592L, HP 8593E, and HP 8596E spectrum analyzers, remove the cable tie **(2)** that secures the A3A11 and A3A12 assemblies to the W10 semi-rigid cable. See Figure 7-1.
5. On HP 8592L, HP 8593E, and HP 8596E spectrum analyzers, disconnect the W37 semi-rigid cable **(3)** from the 100 MHz COMB OUT connector on the front-frame assembly.
6. Remove the two screws **(1)** that secure the front frame to the main chassis.
7. If the instrument came equipped with a tracking generator, disconnect the tracking generator output semi-rigid cable **(5)** from the RF OUT connector on the front-frame assembly.
8. Disconnect the W10 semi-rigid cable **(4)** from the INPUT connector.
9. Disconnect W3 **(6)** from A1R1, the front-panel INTEN control. It may be necessary to remove the speaker bracket from LS1 as well as A22 10 MHz reference in order to get to W3.
10. If the instrument came equipped with an A102 AM/FM Speaker and TV Synch Trigger (Option 102) or A103 Quasi Peak Detector (Option 103), disconnect W102 from the VOL control wiring connector **(8)** at A1R1.
11. Disconnect W1 **(7)** from A16J9.
12. Place the analyzer with the front frame forward and the top side facing up on the worksurface.
13. Disconnect W7 from A9J2.
14. Remove the five screws **(9)** that secure the front frame to the main chassis sides. There are three screws on the right and two screws on the left.

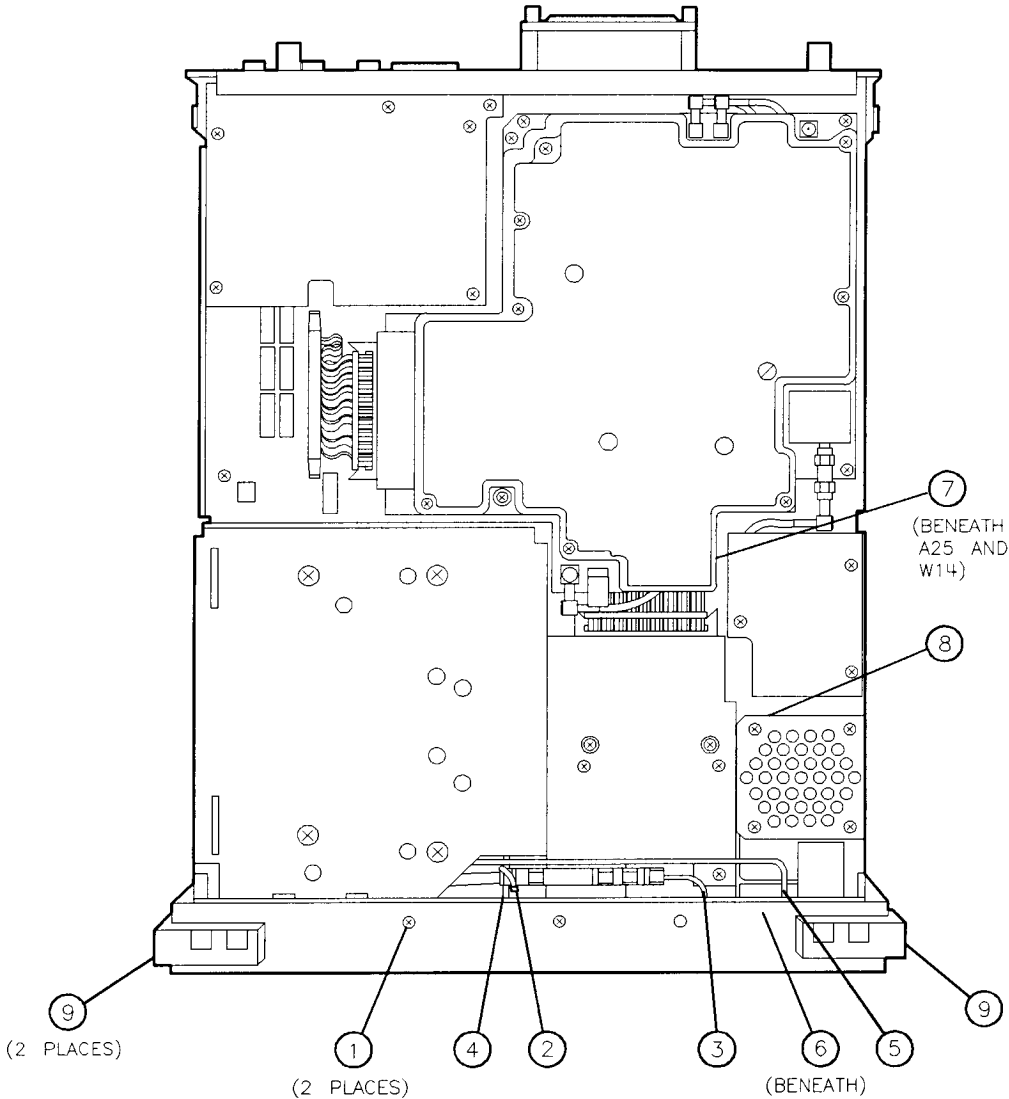
---

**Caution** To prevent damage to the semi-rigid cables, make sure they are completely disconnected from the front panel connectors *before* removing the front frame.

---

15. Separate the front frame from the main chassis and disconnect the W4 ribbon cable from the A1A1 Keyboard assembly.
16. Remove the front-frame assembly.

**A1 Front-Frame Assembly**



sh2120e

**Figure 7-1. A1 Front-Frame Replacement**

## A1 Front-Frame Assembly

### Replacement

1. Connect W7 to A9J2 and route the cable down between the A2 Display assembly and the Front-End assembly.
2. Connect the W4 ribbon cable to the A1A1 Keyboard assembly.
3. Align the W10 semi-rigid cable **(4)** with the INPUT connector while replacing the front frame on the main chassis. Make sure that the cables attached to the front frame are not pinched between adjacent assemblies. See Figure 7-1.
4. Replace the five screws **(9)** that secure the front frame to the main chassis sides. There are three screws on the right and two screws on the left.
5. Place the analyzer with the front frame forward and the bottom side facing up on the worksurface.
6. Connect W1 **(7)** to A16J9.
7. Connect W3 **(6)** to the connector from A1R1, the front-frame INTEN control.
8. If the instrument came equipped with an A102 AM/FM Speaker and TV Synch Trigger (Option 102), connect W102 to the VOL control wiring connector **(8)** at A1R1.
9. If the instrument came equipped with a tracking generator, connect the tracking generator output semi-rigid cable **(5)** to the RF OUT connector on the front-frame assembly to 10 inch-pounds.
10. Connect the W10 semi-rigid cable **(4)** at the INPUT connector to 10 inch-pounds.
11. On HP 8592L, HP 8593E, and HP 8596E spectrum analyzers, connect the W37 semi-rigid cable **(3)** to the 100 MHz COMB OUT on the front-frame assembly.
12. On HP 8592L, HP 8593E, and HP 8596E spectrum analyzers, replace the cable tie **(2)** around W10 and the A3A11 and A3A12 assemblies. Tighten the cable tie to secure the A3A11 and A3A12 assemblies to the W10 semi-rigid cable.
13. Replace the two screws **(1)** that secure the front frame to the main chassis.
14. If the instrument came with an A17 Memory Card Reader, replace it. Refer to the “A17 Memory Card Reader” replacement procedure.
15. Replace the instrument cover assembly. Refer to the “Instrument Cover” replacement procedure.

## A1A1 Keyboard/Front-Panel Keys

### This procedure applies to:

HP 8590 E-Series and L-Series spectrum analyzers  
HP 8591C cable TV analyzers  
HP 8594Q QAM analyzers

### Removal

1. Remove the front frame from the analyzer. Refer to the “A1 Front-Frame Assembly” removal procedure.
2. Place the front frame face down on the worksurface.
3. Refer to Foldout 12-5 at the end of Chapter 12 to remove the keyboard assembly.
4. Note that the front-panel menu key actuators are part of the display bezel assembly and are not replaceable. If the menu keys are damaged, replace the bezel assembly.

### Replacement

1. Refer to Foldout 12-5 at the end of Chapter 12 to replace the keyboard assembly.
2. Install the front frame to the analyzer. Refer to the “A1 Front-Frame” replacement procedure.

---

## A2 Display

### This procedure applies to:

HP 8590 E-Series and L-Series spectrum analyzers  
HP 8591C cable TV analyzers  
HP 8594Q QAM analyzers

---

**Caution** Use ESD precautions when performing this replacement procedure.

---

### Removal

1. Remove the instrument cover assembly. Refer to the “Instrument Cover” removal procedure.
2. Remove the A17 Memory Card Reader. Refer to the “A17 Memory Card Reader” removal procedure.
3. Remove the A1 Front-Frame assembly. Refer to the “A1 Front-Frame Assembly” removal procedure.
4. Place the instrument on the worksurface with the bottom side facing up.
5. Remove the three screws **(1)** that secure the A2 Display to the chassis. See Figure 7-2.
6. Disconnect the W2 wire harness **(2)** from A16J8 on the A16 Processor/Video Board assembly.
7. Place the instrument on its right side.
8. Disconnect the W51 wire harness from the power supply and, on HP 8592L and HP 8593E spectrum analyzers, from the A7 Analog Control assembly.

---

**Caution** The plastic locking clip on the W3 connector **(3)** is fragile. Protect the connector by wrapping it with a piece of tape before pushing it down into the slot **(4)** on the instrument chassis.

---

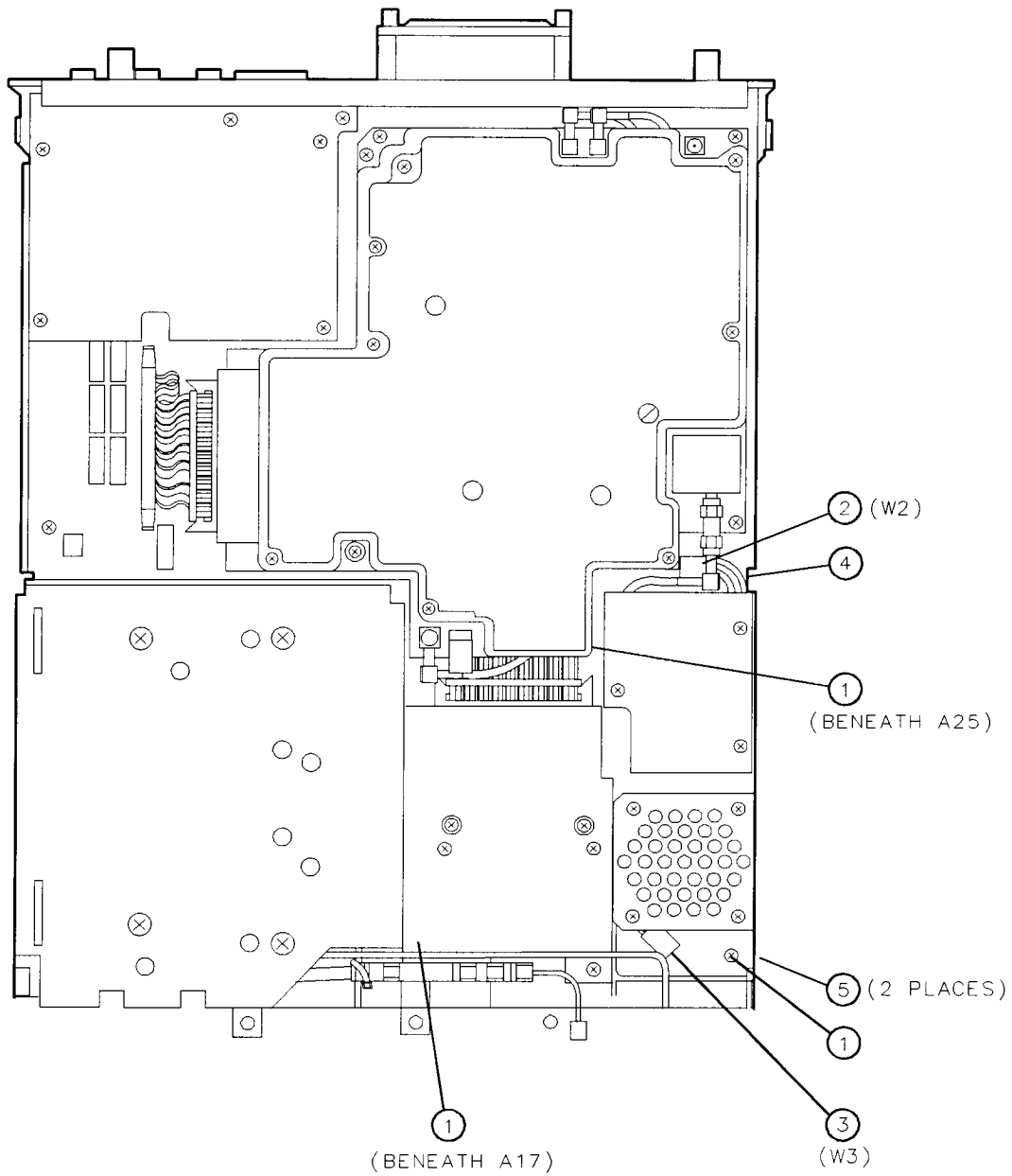
9. Push the W2 wire harness **(2)** and the W3 wire harness **(3)** down into the slot **(4)** on the instrument chassis.
10. Hold the display in position and remove the two screws **(5)** that secure the display to the left side of the instrument chassis.

---

**Caution** A corner of the A8 Power Supply partially blocks the slot **(4)** in the instrument chassis. Make sure that the display’s wiring harness and connectors do not jam between the power supply and the chassis.

---

11. Slowly remove the display assembly from the front of the instrument. Continue to route W2 and W3 through the slot **(4)** as the display is removed.



sh2105e

**Figure 7-2. A2 Display Replacement**

## A2 Display

12. Remove the screws and the fiber washer (6) that secure the A2 Display to its enclosure (7). See Figure 7-4.
13. Slowly pull the display out of its enclosure while routing W2 and W3 through the opening in the enclosure (8).

---

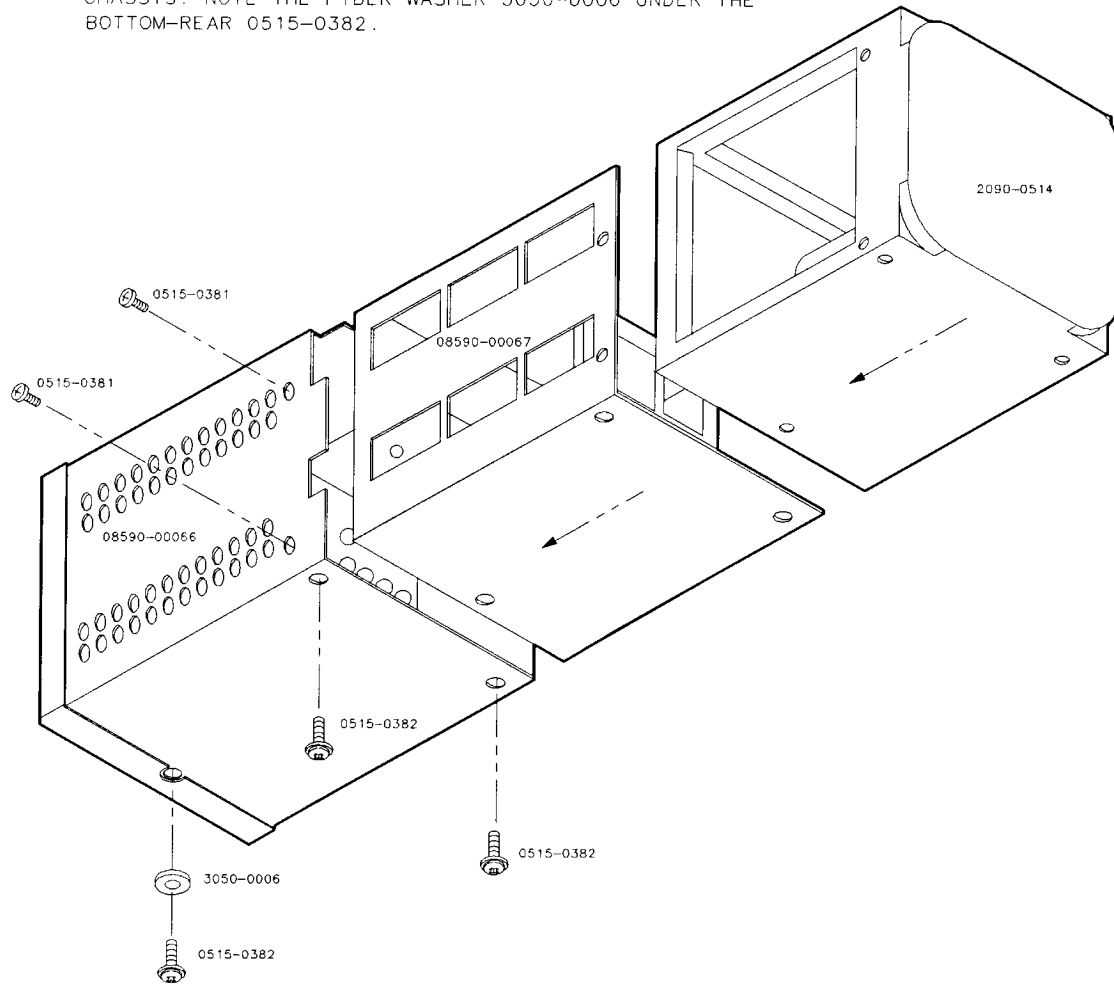
**Warning**     **A high-voltage potential may remain within the A2 Display assembly for some time after it has been removed from the instrument. Do not attempt to remove the post-accelerator lead from the cathode-ray tube.**

---

14. Disconnect W2 (9) and W3 (10) from the display.

### ASSEMBLY

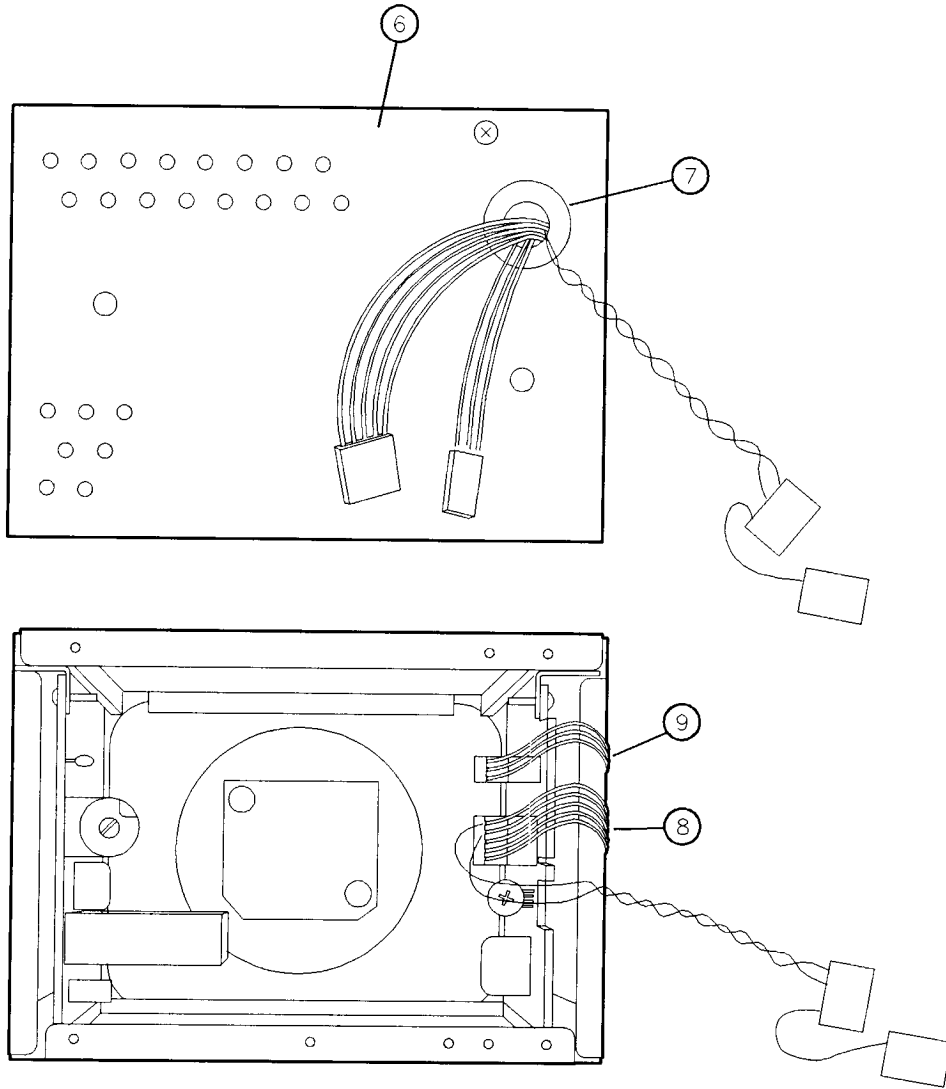
1. INSTALL THE 08590-00067 AND 2090-0514 INTO THE 08590-00066.
2. INSTALL THE CRT ASSEMBLY (08590-00066/08590-00067/2090-0514) INTO THE INSTRUMENT CHASSIS.
3. INSTALL HARDWARE TO FASTEN THE CRT ASSEMBLY TO THE (2090-0514) CHASSIS. NOTE THE FIBER WASHER 3050-0006 UNDER THE BOTTOM-REAR 0515-0382.



dq121

**Figure 7-3. CRT Assembly**





sq14ce1

Figure 7-4. A2 Display, Rear View

## A2 Display

### Replacement

1. Connect W2 and W51 (8) and W3 (9) to the A2 Display. See Figure 7-4.

---

**Caution** The plastic locking clip on the W3 connector (9) is fragile. Protect the connector by wrapping it with a piece of tape before pushing it through the opening (7) on the enclosure.

---

2. Place the display close to the front of the enclosure and route W2, W51, and W3 out through the opening (7).
3. Slowly push the display into the enclosure while pulling W2, W51, and W3 through the opening (7).
4. Place the instrument on the worksurface so that it is resting on its right side.
5. Position the display assembly part of the way into the front of the instrument.
6. Begin to push W2 and W3 out through the slot (4) in the instrument chassis. See Figure 7-2.

---

**Caution** A corner of the A8 Power Supply partially blocks the slot (4) in the instrument chassis. Make sure that the display's wiring harness and connectors do not jam between the power supply and the chassis.

---

7. Replace the display in the instrument while carefully pulling W2 and W3 through the slot (4) in the instrument chassis.
8. Hold the display as far in as possible and replace the two screws (5) that secure the display to the left side of the instrument chassis.
9. Connect the W51 wire harness to the power supply and, on HP 8592L and HP 8593E spectrum analyzers, to the A7 Analog Control assembly. See Figure 7-8.
10. Place the instrument on the worksurface with the bottom side facing up.
11. Remove the tape protecting the plastic clip on W3 (3).
12. Connect W2 (2) to A16J8 on the A16 Processor/Video Board assembly.
13. Replace the three screws (1) that secure the display to the chassis.
14. Replace the A1 Front-Frame assembly. Refer to the "A1 Front-Frame Assembly" replacement procedure.
15. Replace the A17 Memory Card Reader. Refer to the "A17 Memory Card Reader" replacement procedure.
16. Replace the instrument cover assembly. Refer to the "Instrument Cover" replacement procedure.

---

## RF Assembly

### This procedure applies to:

HP 8590L and 8591E spectrum analyzers  
HP 8591C cable TV analyzers

---

**Caution** Use ESD precautions when performing this replacement procedure.

---

### Removal

1. Remove the instrument cover assembly. Refer to the "Instrument Cover" removal procedure.
2. Place the analyzer with the bottom side facing up.
3. Disconnect the W10 semi-rigid cable (2) from the INPUT connector. See Figure 7-5.
4. If the instrument came equipped with a tracking generator, disconnect W31 (8) from the RF OUTPUT.
5. On HP 8591E spectrum analyzers and HP 8591C cable TV analyzers, disconnect W20 (7) from counter lock assembly A25A1J1.
6. Remove the four screws (3) securing the RF assembly to the chassis.
7. Place the analyzer with the top side facing up.
8. Clip the tie wraps (9) which secure W8 and W9 to the other cables.
9. Disconnect the W9 cable (4) from A9J4, the 321.4 MHz INPUT.
10. Disconnect the W8 cable (5) from A9J5, the 600 MHz OUT.
11. Remove the four screws (10) securing the A7 Analog board to the chassis. Note that one of these is a pozidrive screw which attaches to the RF assembly.
12. Remove the A7 Analog Interface assembly. Refer to the "A7 Analog Interface Assembly" removal procedure.
13. If the instrument came equipped with a tracking generator assembly, disconnect the SMA cables connected to the A7A1 Tracking Generator Control assembly.
14. Remove the bracket (11) which secures the RF assembly to the IF section.

---

**Caution** To prevent cable damage, make sure that W10 and W31 are completely disconnected *before* removing the RF assembly.

---

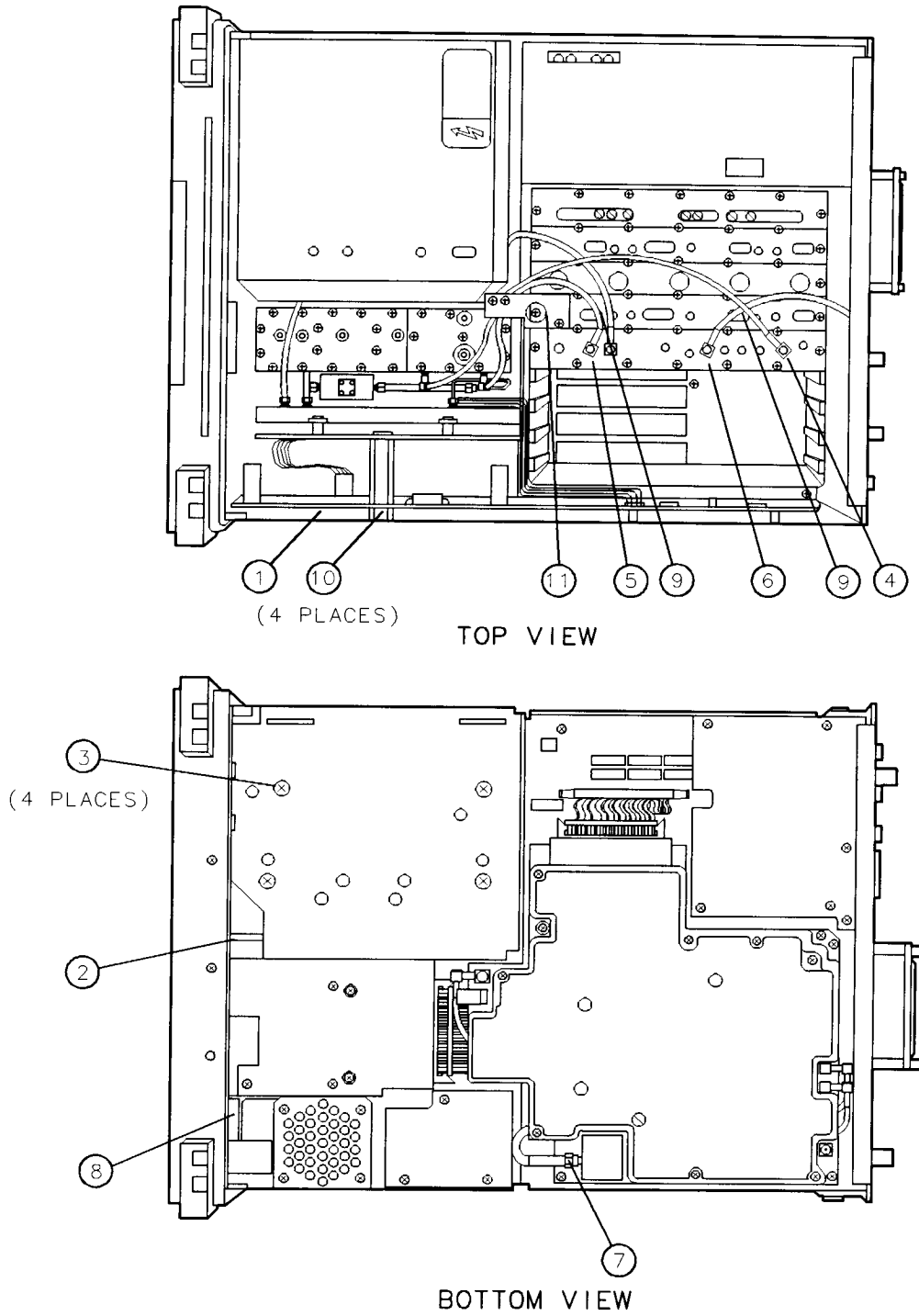
15. Carefully remove the RF assembly from the analyzer.

---

**Note** To disassemble or assemble the RF assembly, refer to the foldouts at the end of Chapter 12. Chapter 11 provides cable location information for the RF assembly and the tracking generator assembly.

---

# RF Assembly



**Figure 7-5. RF Assembly Replacement**

sh252e

**Replacement**

1. Place the analyzer with the top side facing up.
2. Align the W10 semi-rigid cable **(2)** with the INPUT connector, and W31, if equipped with a tracking generator, with the OUTPUT connector as the Rf assembly is placed into the analyzer. Make sure that none of the cables are pinched while installing the RF assembly.
3. Replace the bracket **(11)** which secures the RF assembly to the IF section.
4. Replace the A7 Analog Interface assembly **(1)**. Refer to the “A7 Analog Interface Assembly” replacement procedure.
5. Connect W9 **(4)** to A9J4, and W8 **(5)** to A9J5.
6. Replace the tie wraps **(9)** which secure W8 and W9 to the other cables.
7. Place the analyzer with the bottom side facing up.
8. Replace the four screws **(3)** that secure the RF assembly to the analyzer.
9. Tighten the W10 semi-rigid cable **(2)** on the INPUT connector to 10 inch-pounds.
10. If the instrument came equipped with a tracking generator assembly, tighten the W31 semi-rigid cable **(8)** on the OUTPUT connector to 10 inch-pounds.
11. Replace the instrument cover assembly. Refer to the “Instrument Cover” replacement procedure.

---

## A3 Front-End Assembly

### This procedure applies to:

HP 8592L spectrum analyzers  
HP 8593E spectrum analyzers  
HP 8594E spectrum analyzers  
HP 8594L spectrum analyzers  
HP 8594Q QAM analyzers  
HP 8595E spectrum analyzers  
HP 8596E spectrum analyzers

### General Instructions

---

- Caution**
- The A3 Front-End assembly has static-sensitive components. Read “Protection from Electrostatic Discharge” in Chapter 1 before proceeding.
  - Hold the A3A3 Low-Pass Filter, A3A9 Bandpass Filter, and FL1 Low-Pass Filter firmly in place when loosening or tightening either of their semi-rigid cables. The cables can be easily damaged if the filters are allowed to twist.
  - The bracket assembly is made up of four separate brackets. Whenever the brackets are called out in a replacement procedure, they are designated by the letters A through D, as illustrated in Figure 7-6.
- 

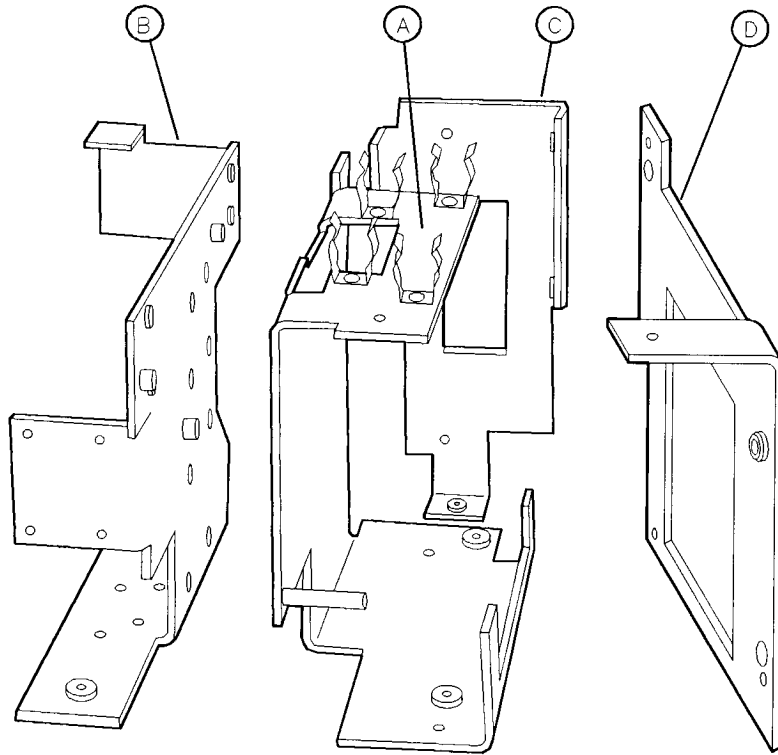
To disassemble the A3 Front-End assembly, refer to the foldouts at the end of Chapter 12. Chapter 11 provides cable location information for the various option and model mixes.

The torque specification for all of the SMA connections within the A3 Front-End assembly is 10 inch-pounds. Be sure that the assemblies are securely mounted during initial loosening or final torquing of the semi-rigid cables.

---

- Note**
- When replacing the A3A8 YTF, closely examine the replacement YTF. It may have its wiring label installed in one of two ways. Either orientation is correct as long as A3A8J2 is connected to the SMA adapter and proper polarity of the tuning wires is observed. Use the following schedule to connect the wires to the replacement YTF:
- Connect the violet wire to one “HTR” terminal.
  - Connect the green wire to the other “HTR” terminal.
  - Connect the orange wire to the “– Tune” terminal.
  - Connect the brown wire to the “+ Tune” terminal.
-

**A3 Front-End Assembly**



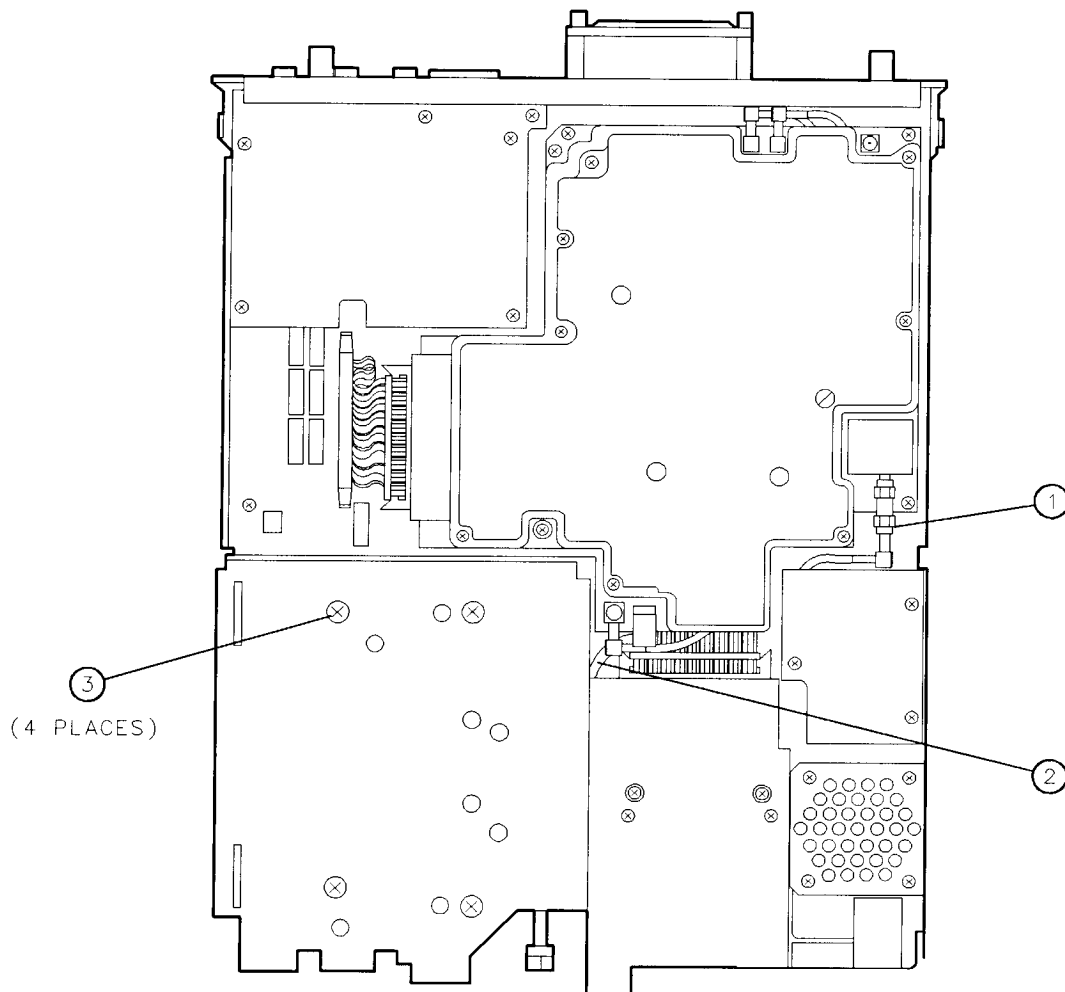
sh251e

**Figure 7-6. A3 Front-End Bracket Assembly**

## A3 Front-End Assembly

### Removal

1. Remove the instrument cover assembly. Refer to the “Instrument Cover” removal procedure.
2. Remove the front-frame assembly. Refer to the “A1 Front-Frame Assembly” removal procedure.
3. Place the instrument so that its left side is resting on the worksurface.
4. Disconnect the W20 coaxial cable (1) from AT1, the 10 dB pad. See Figure 7-7.
5. Push W20 through the slot (2) on the instrument chassis.
6. Remove the four screws (3) that secure the A3 Front-End assembly to the instrument chassis.



sh253e

**Figure 7-7. A3 Front-End Replacement, Bottom View**



## A3 Front-End Assembly

7. Place the instrument on the worksurface with the top side facing up.
8. Remove the A7 Analog Interface assembly. Refer to the “A7 Analog Assembly” removal procedure.
9. Note how the cables attached to the A9 Third Converter assembly are dressed. (This information will be used later during the “A3 Front-End Assembly” replacement procedure.)

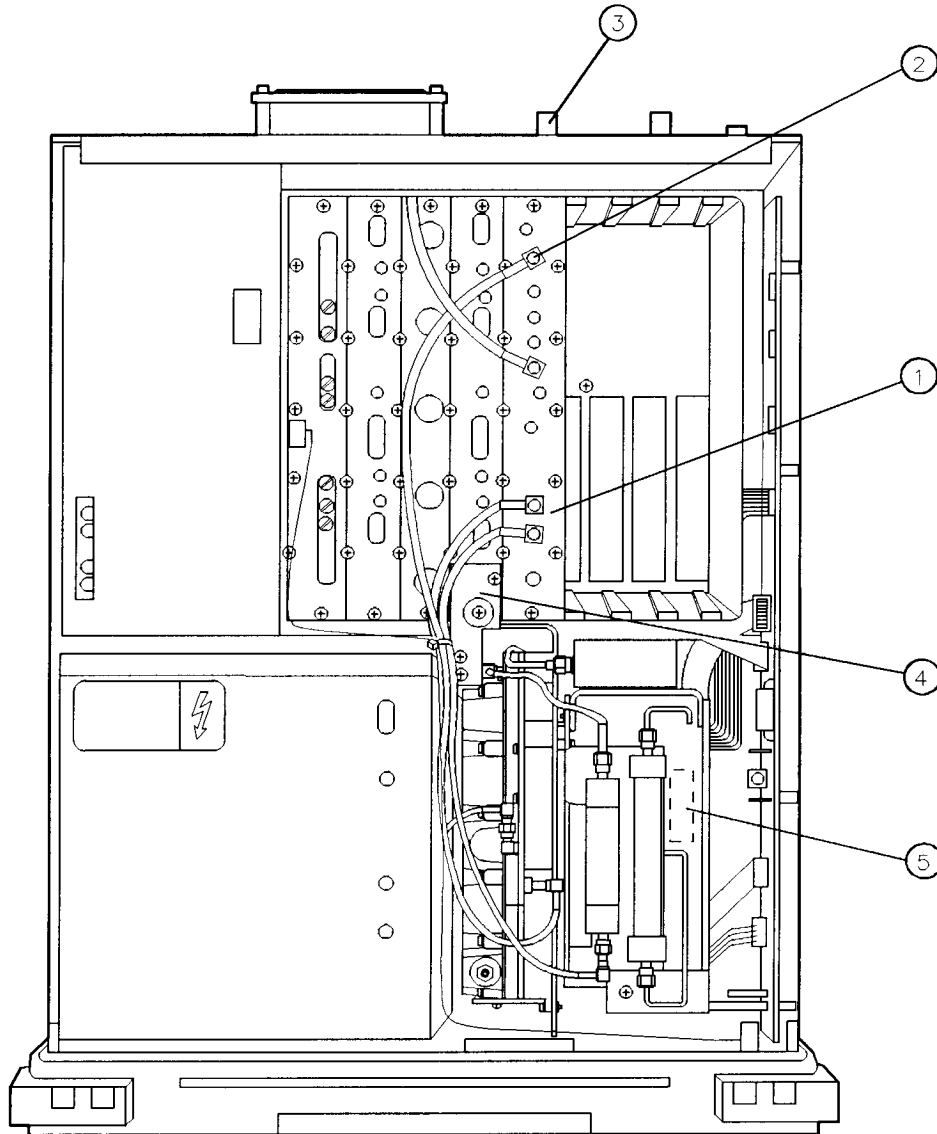
---

**Note** Some card-cage options have a different cable dress which include the use of tie-wraps. The tie-wraps are required to hold the wires in place during installation of the instrument cover.

---

10. Disconnect W8 (1) from A9J5 and W9 (2) from A9J4. See Figure 7-8.
11. If the instrument came equipped with a tracking generator (Option 010), disconnect W39 from A10J1 and W38 from A10J2.
12. If the instrument came equipped with an LO Output on the rear panel (Option 009), disconnect W42 (3) from the LO OUTPUT connector on the rear-frame assembly.
13. Remove the three screws and two washers (4) from the front-end-to-IF support bracket, then remove the bracket.
14. Tuck the cables and wire harness that are attached to the front-end assembly down into the space (5) between the “D” bracket and the A3A9 filter. This reduces the possibility that wires will be damaged while the front-end assembly is removed.
15. Carefully lift the A3 Front-End assembly out of the instrument.

## A3 Front-End Assembly



sh2127e

**Figure 7-8. A3 Front-End Replacement, Top View**

### Replacement

1. Tuck all cables and wire harnesses on the A3 Front-End assembly (except for cables W20 and W24) down into the space **(5)** between the “D” bracket and the A3A9 filter. This reduces the possibility of damaging wires while replacing the front-end assembly. See Figure 7-8.
2. Place the instrument on the worksurface with the top side facing up.
3. Set the front-end assembly on top of the A2 Display assembly and route the W20 coaxial cable into the slot on the instrument chassis that is just below the lower-right rear corner of the A2 Display assembly.
4. Position the front-end assembly over the front-end section of the instrument chassis.

---

**Caution**      Protect the center pin of the W10 semi-rigid cable and make sure that cables W20 and W24, as well as all other wiring, are not pinched between the front-end assembly and the instrument.

---

5. Carefully lower the front-end assembly into the instrument chassis.
6. Replace the front-end-to-IF support bracket, and install the three screws and two washers **(4)** on the bracket without tightening.
7. Connect W8 **(1)** to A9J5 and W9 **(2)** to A9J4. See Figure 7-8.
8. If the instrument came equipped with an LO Output on the rear panel (Option 009), connect W42 **(3)** to the LO OUTPUT connector on the rear-frame assembly.
9. Place the instrument so that its left side is resting on the worksurface.
10. Install and tighten the four screws **(3)** that secure the front-end assembly to the chassis. See Figure 7-7.
11. Route W20 through the slot **(2)** in the instrument chassis and under the ribbon cable.
12. Connect W20 **(1)** to the AT1 assembly and tighten it to 10 inch-pounds.
13. Place the instrument on the worksurface with the top side facing up.
14. Tighten the three screws **(4)** on the front-end-to-IF support bracket. See Figure 7-8.
15. Replace the A7 Analog Board assembly. Refer to the “A7 Analog Interface Assembly” replacement procedure.
16. Dress all cables as noted during the removal procedure.
17. For card-cage options with additional wiring, replace the tie-wraps and dress the wiring so that there will be no interference with the instrument cover assembly.
18. Replace the front-frame assembly. Refer to the “A1 Front-Frame Assembly” replacement procedure.
19. Replace the instrument cover assembly. Refer to the “Instrument Cover” replacement.

---

## A7 Analog Interface Assembly

### This procedure applies to:

HP 8590 E-Series and L-Series spectrum analyzers  
HP 8591C cable TV analyzers  
HP 8594Q QAM analyzers

---

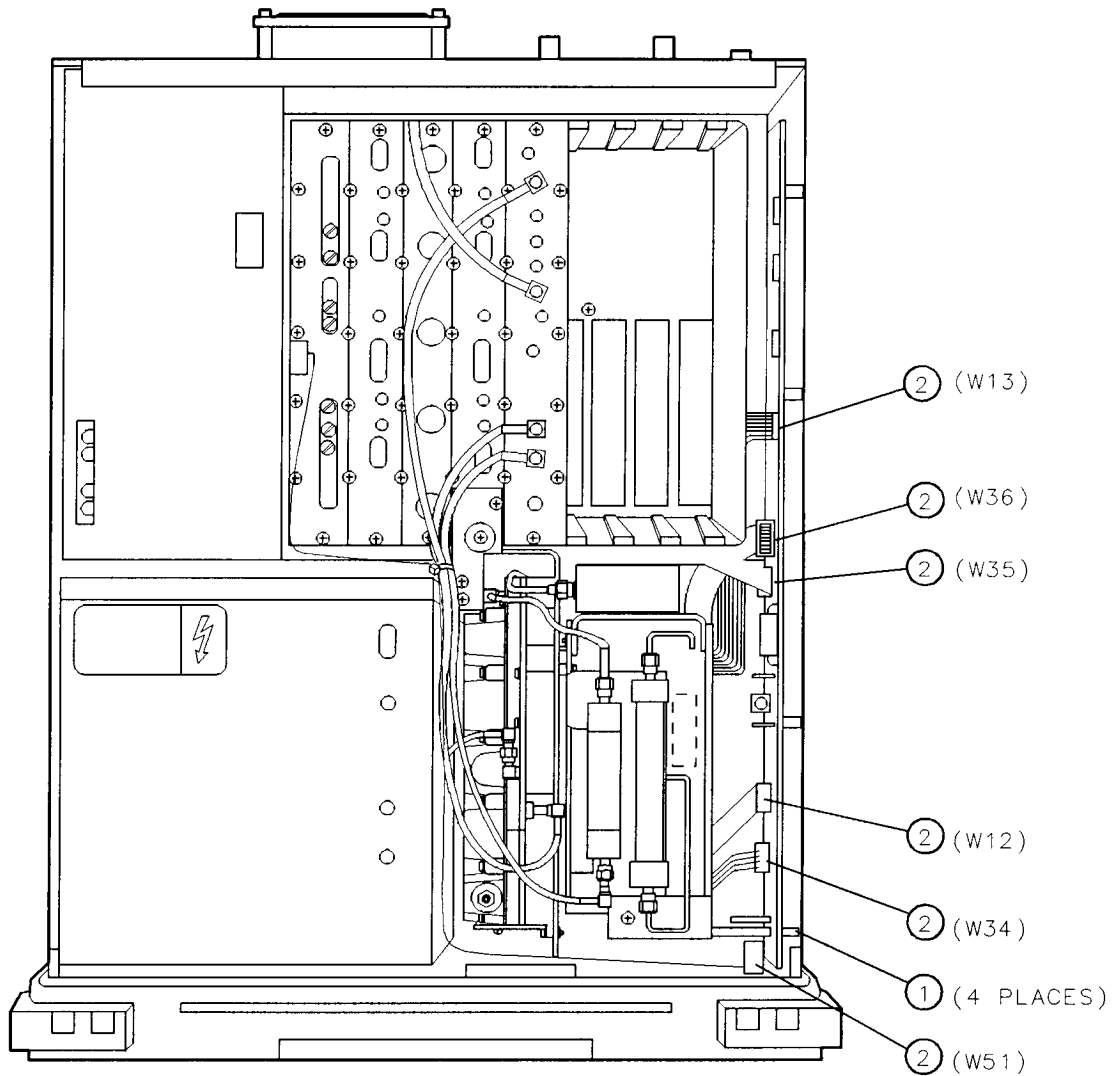
**Caution** Use ESD precautions when performing this replacement procedure.

---

### Removal

1. Remove the instrument cover assembly. Refer to the “Instrument Cover” removal procedure.
2. Remove the four screws **(1)**, which secure the A7 Analog Interface assembly to the right side of the instrument chassis. See Figure 7-9.
3. Note how the cables and wiring attached to the A7 assembly are dressed. (This information will be used later during the replacement procedure.)
4. Pull the A7 assembly partially out of its slot and disconnect W12, W13, W34, W35, W36, and W51 from the A7 assembly **(2)**.
5. If you have an A7A1 Tracking Generator Control assembly on your HP 8590L, HP 8591C, or HP 8591E, you will need to remove the SMA cables attached to it as you are removing the A7 assembly.
6. Remove the A7 assembly and place it in a static-safe container.

# A7 Analog Interface Assembly



sh254e

**Figure 7-9. A7 Analog Interface Assembly Replacement**

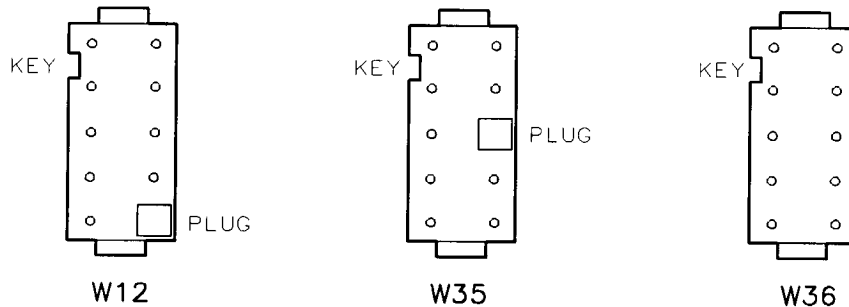
## A7 Analog Interface Assembly

### Replacement

---

**Caution** Serious instrument damage will result if any wire connector is not installed correctly. A connector can be installed backwards or in the wrong position. Inspect each connector and make sure it is not damaged or missing a key plug. Also inspect the A7 assembly for bent connector pins. Incorrect connector installation is most likely to occur with the connectors on W12, W35 and W36. See Figure 7-10.

---



sh255e

**Figure 7-10. End View of Connectors for W12, W35, and W36**

1. Lower the A7 assembly part way into the A7 slot and connect W12, W13, W34, W35, W36, and W51 **(3)** to the A7 assembly.
2. If your HP 8590L, HP 8591C, or HP 8591E has an A7A1 Tracking Generator Control assembly, you will need to reconnect the SMA cables to it as you lower the A7 assembly into the instrument.

---

**Note** To ensure proper installation of the A7 assembly, perform the following:

- a. Arrange all wiring so that the wires do not press against the A7 assembly.
- b. Align the two tabs on the bottom of the A7 assembly with the slots on the instrument chassis.
- c. Avoid bending the pins on the A15 motherboard connector while positioning the A7 assembly.
- d. Align the A7 Analog Interface assembly connector with the A15 motherboard connector carefully.

3. Install the A7 assembly. Slide the A7 assembly toward the back of the A7 slot so that the front-end-to-chassis spacer, mounted on the leading edge of the A7 assembly, will drop smoothly into place.
4. Replace the four screws **(1)** that secure the A7 assembly to the right side of the chassis.
5. Replace the instrument cover assembly. Refer to the "Instrument Cover" replacement procedure.

## A8 Power Supply

### This procedure applies to:

HP 8590 E-Series and L-Series spectrum analyzers  
HP 8591C cable TV analyzers  
HP 8594Q QAM analyzers

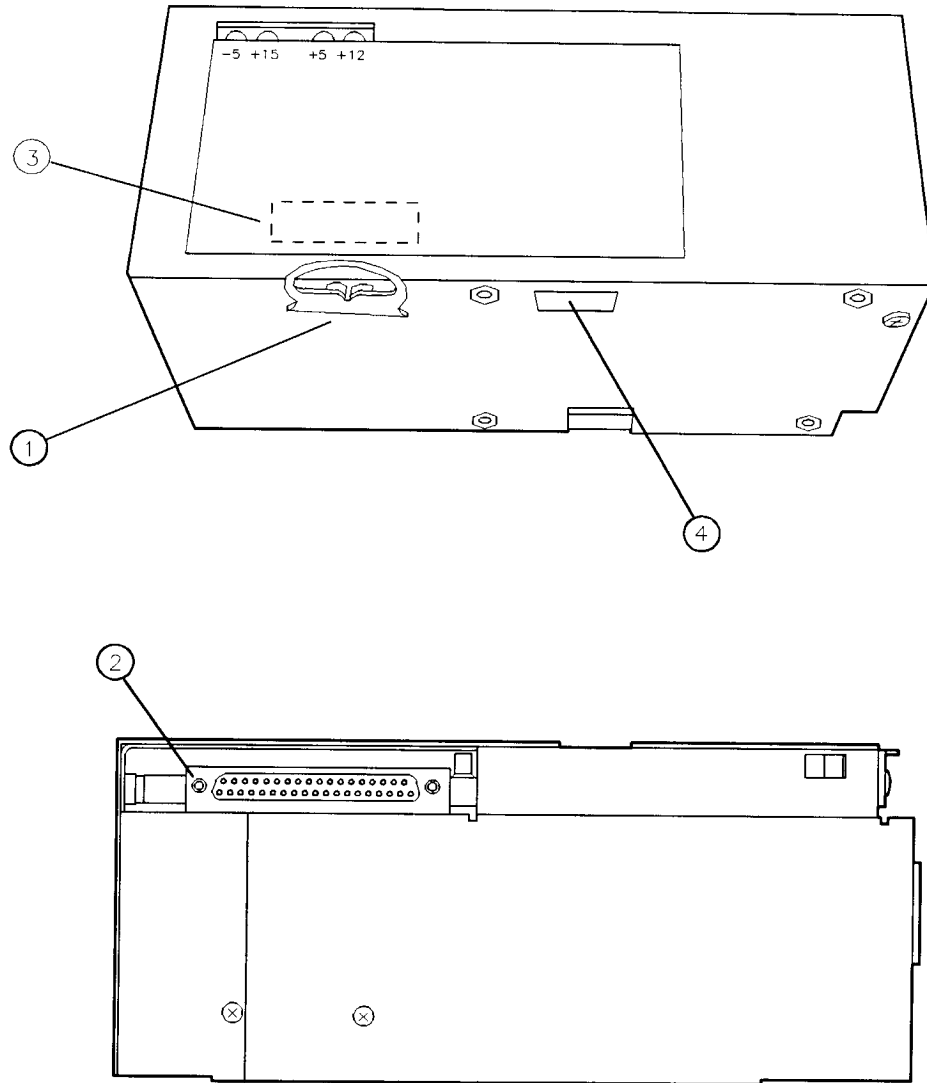
### Removal

1. Remove the instrument cover assembly. Refer to the “Instrument Cover” removal procedure.
2. Remove the instrument rear frame. Refer to the “Rear-Frame Assembly” removal procedure.
3. Remove W51 (4) from the A8 Power Supply.
4. Remove the four TORX screws and washers on the left side of the chassis adjacent to the A8 Power Supply.
5. Grasp the power supply pull-tab (1), pull straight up, and remove the A8 assembly from the instrument chassis. See Figure 7-11.

### Replacement

1. Position the 37-pin connector (2) on the power-supply so it is able mate with the A15 motherboard connector.
2. Lower the A8 assembly into the instrument chassis.
3. With the connectors properly aligned, push down on top of the A8 assembly close to the pull tab (3). The assembly is correctly installed when the four mounting holes on the left side of the chassis are aligned with the tapped holes on the A8 assembly.
4. Replace the four screws and washers on the left side of the chassis.
5. Replace the rear frame. Refer to the “Rear-Frame Assembly” replacement procedure.
6. Replace the instrument cover assembly. Refer to the “Instrument Cover” replacement procedure.

## A8 Power Supply



sh256e

**Figure 7-11. A8 Power Supply Replacement**



---

## A15 Motherboard and IF Extrusion

### This procedure applies to:

HP 8590 E-Series and L-Series spectrum analyzers  
HP 8591C cable TV analyzers  
HP 8594Q QAM analyzers

---

**Caution** Use ESD precautions when performing this replacement procedure.

---

### Removal of the A15 Motherboard

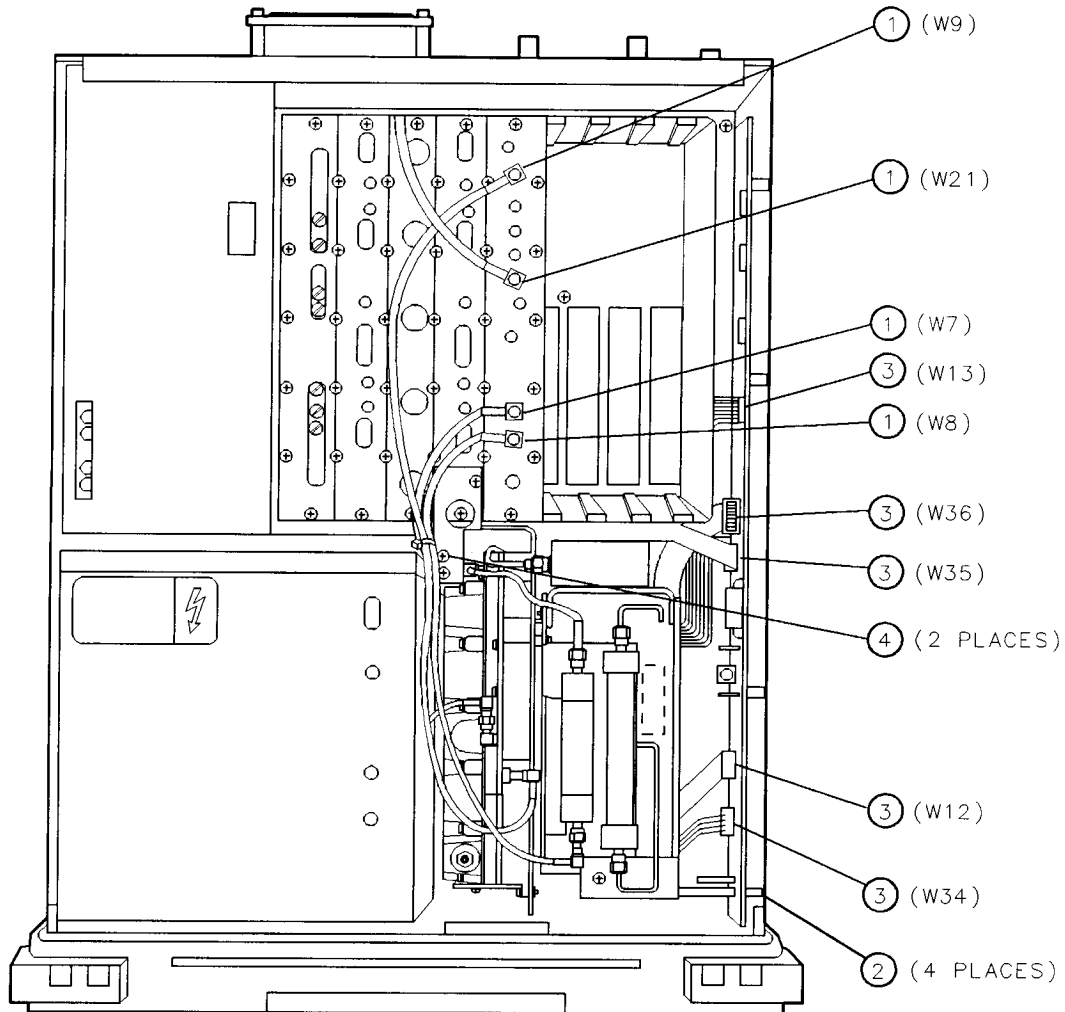
1. Remove the instrument cover assembly. Refer to the “Instrument Cover” removal procedure.
2. Remove the A8 Power Supply. Refer to the “A8 Power Supply” removal procedure.
3. Remove the A7 Analog Interface assembly. Refer to the “A7 Analog Assembly” removal procedure.
4. Remove the rear-frame assembly. Refer to the “Rear-Frame Assembly” removal procedure.
5. If there are card cage options installed, perform the following:
  - Note the position of the option cards for reassembly.
  - Note how the wiring and cables to each option are dressed.
  - Remove all cable ties.
  - Disconnect all cables and wire harnesses attached to each option.
  - Remove the option assemblies from the card cage and place them in static-safe containers.
6. Remove W7, W8, W9, and W21 (1) from the A9 Third Converter. See Figure 7-12.
7. Remove the two screws (4) on the front-end-to-IF support bracket.
8. Disconnect the W19 coaxial cable (5) from the A15J18 at the rear of the instrument. See Figure 7-13.
9. Disconnect the B1 Fan wire harness (6) from A15J19 at the rear of the instrument.
10. Remove the 40 screws (7) that secure the five IF board assemblies in the IF extrusion assembly.

---

**Caution** Use the two-prong board-puller tool to remove the IF board assemblies that do not have attached covers. Traces on the printed circuit boards can be damaged if tools with sharp edges are used to remove the IF board assemblies.

---

## A15 Motherboard and IF Extrusion



sh257e

**Figure 7-12. A15 Motherboard Replacement**

11. Remove the five IF board assemblies (8) from the IF extrusion and place them in a static-safe container.
12. Remove the five screws (9) that secure the A15 motherboard to the instrument chassis.

---

**Caution** Do not twist the motherboard sideways while removing it from the instrument. This avoids damaging the connector on the A16 Processor/Video Board assembly that is mated with the connector on the back side of the A15 motherboard.

---

13. Pull the motherboard straight up and out of the instrument chassis. If the motherboard is difficult to remove, a slight rocking action, from front to rear, will help it disconnect from the connector on the processor/video board assembly.
14. If the instrument is equipped with a card-cage:
  - Remove the four screws (10) that secure the card-cage bracket to the sides of the IF extrusion. See Figure 7-13.

## A15 Motherboard and IF Extrusion

- Turn the motherboard assembly upside down on the worksurface and remove the two screws (11) that secure the card-cage bracket to the motherboard. Remove the bracket.

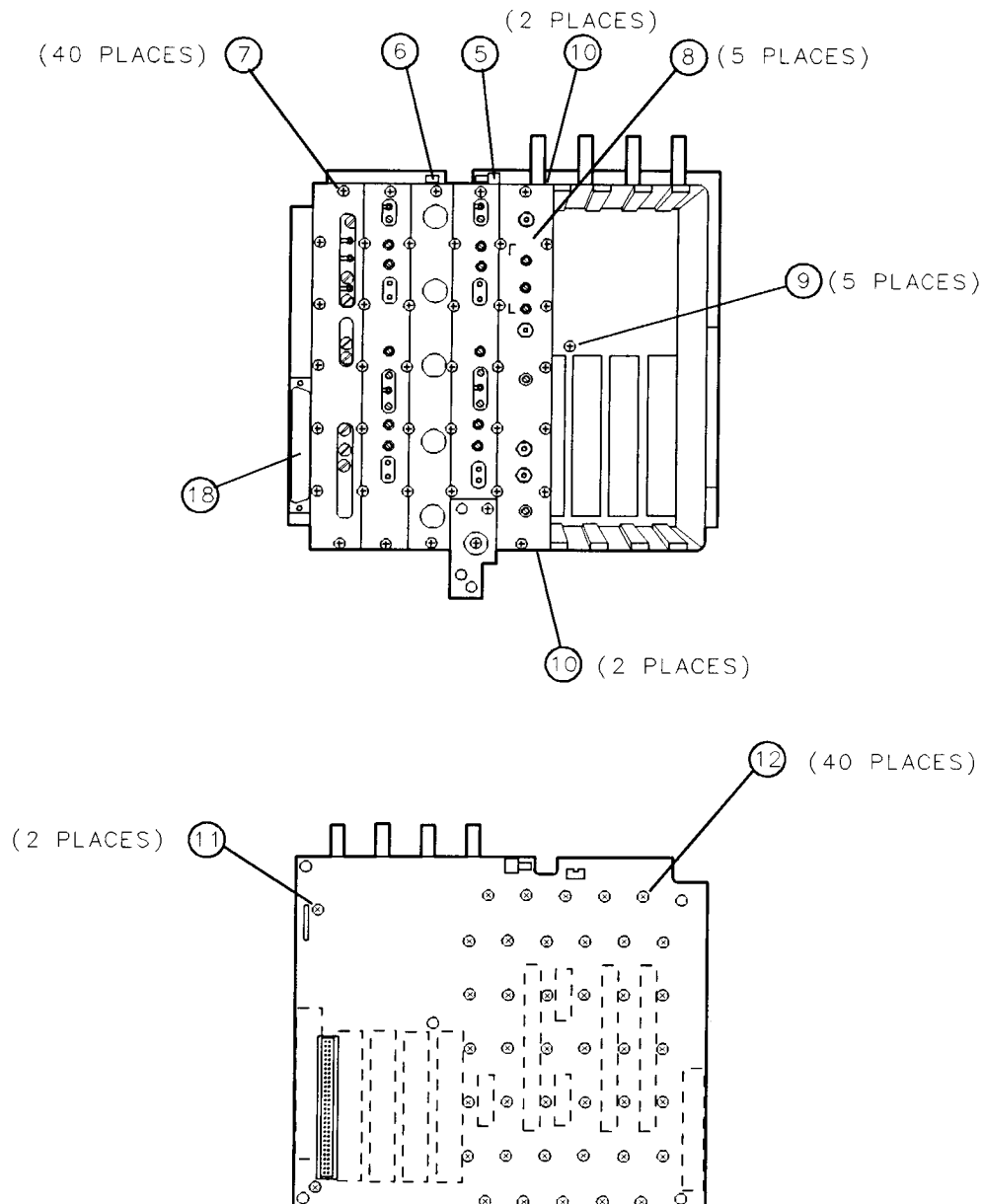
15. Remove the 40 screws (12) that secure the IF extrusion assembly to the motherboard.

---

**Note** If you are replacing a defective A15 motherboard, continue at the “Replacement of the A15 Motherboard” procedure.

---

16. Remove the motherboard and place it in a static-safe container.



sh259e

**Figure 7-13. A15 Motherboard with IF Section**

## A15 Motherboard and IF Extrusion

### Replacement of the A15 Motherboard

17. Position the IF extrusion assembly on the worksurface with its IF board assembly slots facing up. There is no “top” or “bottom” to the IF extrusion; it can be installed with either finished surface mated to the A15 motherboard.
18. Make sure that the mating surfaces of the extrusion assembly and the motherboard are free of debris.

---

**Note** The IF extrusion assembly contains one flat extrusion end-section. Make sure that the extrusion assembly is positioned with the flat extrusion end-section next to the A8 Power Supply connector (18). See Figure 7-13.

---

19. Turn the A15 motherboard upside down and align it with the IF extrusion assembly.
20. Replace the 40 screws (12) that secure the IF extrusion assembly to the motherboard.
21. If the instrument came equipped with a card-cage:
  - a. Replace the card-cage bracket and align it with the two holes on the motherboard.
  - b. Replace the two screws (11) that secure the card-cage bracket to the motherboard without tightening. See Figure 7-13.
  - c. Turn the motherboard assembly right side up and replace the four screws (10) that secure the card-cage bracket to the sides of the IF extrusion assembly.
  - d. Tighten the two screws (11) on the bottom-side of the motherboard.

---

**Caution** Do not twist the motherboard sideways while inserting its connector into the A16 board assembly connector. This prevents damage to either connector.

---

22. Lower the motherboard assembly into the instrument chassis and align it with the connector on the processor/video board assembly.
23. If it is difficult to insert the motherboard connector into the processor/video connector, a slight rocking action, from front to rear, will help it drop into place.
24. Make sure that the holes in the motherboard assembly line up with the holes in the instrument chassis.

---

**Note** If the holes do not line up, loosen the screws that secure the A16 Processor/Video Board assembly to the instrument chassis. Refer to the “A16 Processor/Video Board Assembly” replacement procedure.

---

25. Replace the five screws (9) that secure the A15 motherboard to the instrument chassis.
26. Replace the five IF board assemblies (8) in the IF extrusion.
27. Place each IF cover over its corresponding IF board assembly.
28. Replace the 40 screws (7) that secure the IF board assemblies to the IF extrusion.
29. Connect the B1 Fan wire harness (6) to A15J19 at the rear of the motherboard.
30. Connect the W19 coaxial cable (5) on A15J18 at the rear of the motherboard.
31. Replace the two screws and flat washers (4) on the front-end-to-IF support bracket. See Figure 7-12.
32. Replace the rear frame. Refer to the “Rear Frame” replacement procedure.

## **A15 Motherboard and IF Extrusion**

33. Replace the A7 Analog Board assembly. Refer to the “A7 Analog Interface Assembly” replacement procedure.
34. Replace W7, W8, W9, and W21 (1) on the A9 Third Converter.
35. If the instrument is equipped with card-cage options:
  - Replace the option assemblies in the card-cage slot that they were removed from.
  - Connect all option cables and wire harnesses as noted in the removal procedure.
  - Replace all cable ties as noted in the removal procedure.
  - Position all wiring and cables so that they do not interfere with the installation of the instrument cover.
36. Replace the A8 Power Supply. Refer to the “A8 Power Supply” replacement procedure.
37. Replace the instrument cover assembly. Refer to the “Instrument Cover” replacement procedure.

---

## A16 Processor/Video Board and A16A1 Memory Board Assembly

This procedure applies to:

- HP 8590 E-Series and L-Series spectrum analyzers
- HP 8591C cable TV analyzers
- HP 8594Q QAM analyzers

### Before Replacing the A16 Processor/Video Board Assembly or the A16A1 Memory Board Assembly

Frequency response and cal attenuator correction constants (for the A12 amplitude control board assembly) are stored in battery-backed RAM on the A16A1 memory board assembly. If replacing the A16A1 memory board, record these correction constants using the procedures in Chapter 3 prior to removing the A16A1 memory board assembly.

If not replacing the A16A1 memory board, remove the board by prying the board off the standoffs and place in a static-safe bag.

---

**Note** If you are unable to record the current correction constants, or they are invalid, new correction constants must be generated *after* replacing the A16A1 memory board. Refer to the “10 MHz Reference (Standard),” “Frequency Response,” and “Cal Attenuator Error Correction” adjustment procedures in Chapter 2 of this manual.

---

If valid correction constants can be removed from analyzer memory before replacing the A16A1 memory board, record the correction values using the procedures in Chapter 3.

---

**Caution** Use ESD precautions when performing this replacement procedure.

---

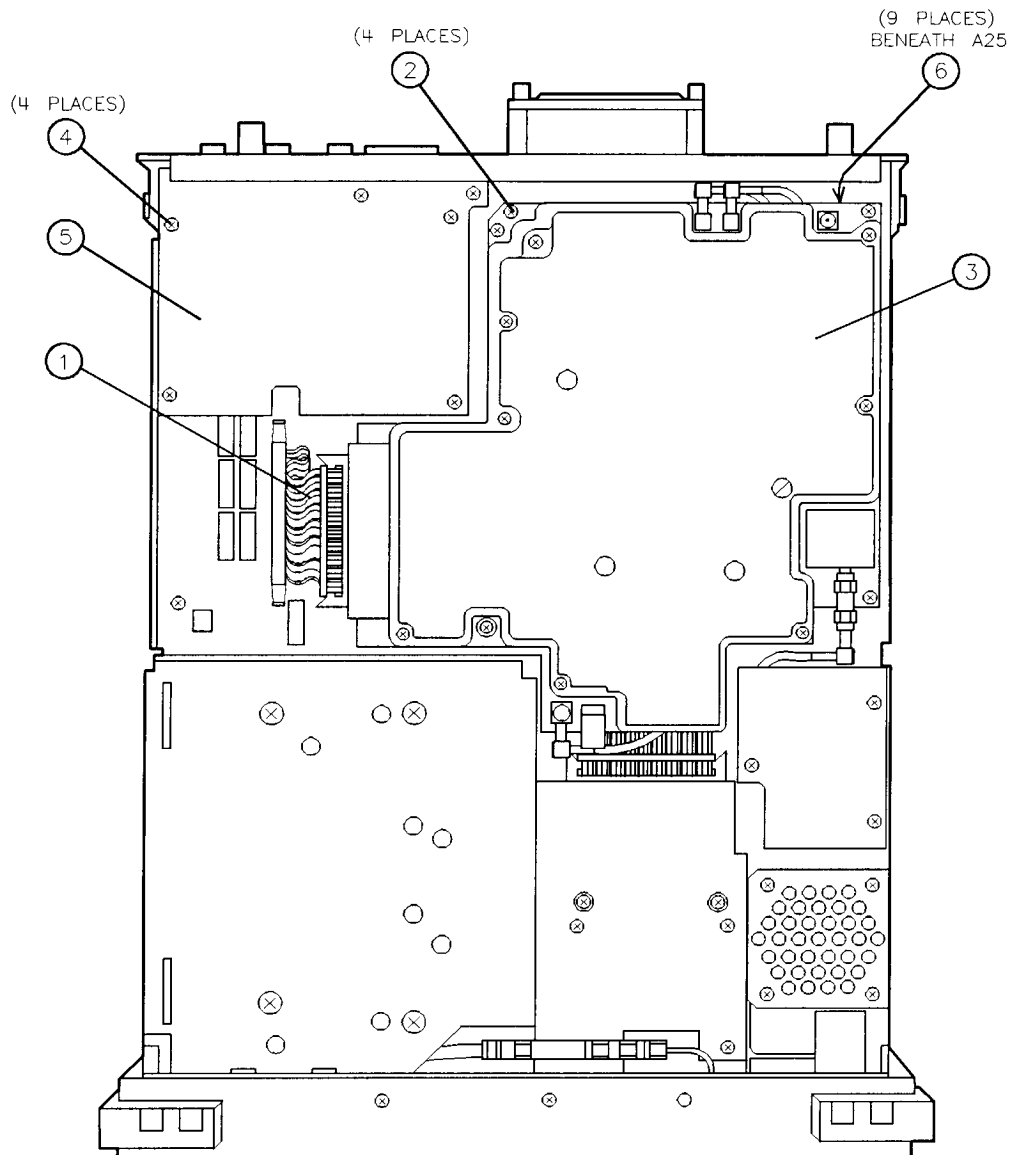
### Removal

1. Remove the instrument cover assembly. Refer to the “Instrument Cover” removal procedure.
2. Place the analyzer on the worksurface with the bottom side facing up.
3. If the instrument is equipped with Option 041 or Option 043:
  - Remove the five screws securing the IO connector to the IO board.
  - Remove the four screws (4) that secure the A40 or A41 IO board assembly.
  - Remove the A40 or A41 IO board assembly (5).
4. Detach the instrument rear frame from the chassis. Pull the rear frame back so that the A16 Processor/Video Board assembly is completely exposed.
5. Disconnect the W14 ribbon cable (1) from A16J2 and A25J4. See Figure 7-14.
6. Remove the four screws (2) that secure the A25 Counter-Lock assembly.
7. Remove the A25 assembly (3).
8. If the instrument is equipped with Option 041 or Option 043.
9. Remove the seven screws (6) that secure the A16 assembly.

## A16 Processor/Video Board and A16A1 Memory Board Assembly

**Caution** The A16 assembly may be damaged if it is placed on a conductive surface. Use a static-safe workstation. Ensure that the assembly is not placed on any conductive material.

10. Remove the A16A1 Memory board assembly and place in a static-safe container.
11. Remove the A16 assembly and place it in a static-safe container.



sh262e

**Figure 7-14. A16 Processor/Video Board Replacement**

## A16 Processor/Video Board and A16A1 Memory Board Assembly

### Replacement

---

**Caution** To prevent damage to connectors A16J1 and A15J2, make sure that they are mated correctly before pushing the A16 assembly into place. Avoid twisting the A16 assembly from side to side during installation.

---

1. Replace the A16 processor/video board assembly.
2. Place two screws in the mounting holes by J5 and J7. Align the A16 board as far toward the rear panel as it will go.
3. Replace the remaining five screws **(6)** that secure the A16 assembly. See Figure 7-14.
4. If the instrument is equipped with Option 041 or 043:
  - Replace the A40 or A41 IO board assembly **(5)**.
  - Replace the four screws **(4)** that secure the A40 or A41 IO board assembly.
5. Replace the A25 counter-lock assembly **(3)**.
6. Replace the four screws **(2)** that secure the A25 assembly.
7. Connect the W14 ribbon cable **(1)** to A16J2 and A25J4.

---

**Caution** To prevent cable and wire damage, ensure all wiring is routed to one side of the SMB connector, A15J18, and through the notch located on the rear edge of the A15 motherboard.

---

8. Replace the rear-frame assembly.
9. Install the IO connector through the rear panel into the IO board and replace the five screws securing the IO connector to the IO board.
10. Replace the instrument cover assembly. Refer to the “Instrument Cover” replacement procedure.



### After Replacing the A16 Processor/Video Board Assembly

The A16A1 stores all the data necessary for analyzer operation including the model identification and serial number. All that is required is to power up the analyzer.

If the A16A1 memory board has lost this data for any reason, it will be necessary to perform the routines outlined in “After Replacing the A16A1 Memory Board Assembly.”

### After Replacing the A16A1 Memory Board Assembly

If no valid correction constants were saved before removal of the A16A1 assembly, new correction constants must be generated.

- Perform “Reset the power-on units” in Chapter 3.
- Perform the “10 MHz Reference” on HP 8590 E-Series, HP 8591Cs, and HP 8594Qs only, “Frequency Response,” and “Cal Attenuator Error” adjustment procedures in Chapter 2 to generate new correction constants.
- Perform the “Instrument Calibration after Reloading the Correction Constants” in Chapter 3.

If valid correction constants were saved before replacing the A16A1 assembly, restore the corrections to RAM memory and recalibrate the analyzer using the following procedures from “Analyzer Initialization” and “Reloading the Correction Constants” in Chapter 3.

- “Reset the power-on units.”
- “Reloading the timebase and flatness-correction constants”
- “Reloading the step-gain correction constants”
- “Instrument Calibration after Reloading the Correction Constants”

---

## A16 Processor/Video Board Firmware ROMs

### This procedure applies to:

HP 8590 E-Series and L-Series spectrum analyzers  
HP 8591C cable TV analyzers  
HP 8594Q QAM analyzers

---

**Caution** Use ESD precautions when performing this replacement procedure.

---

### Removal

1. Remove the instrument cover assembly. Refer to the “Instrument Cover” removal procedure.
2. Remove the A25 Counter-Lock assembly. Refer to the “A25 Counter-Lock” removal procedure.
3. Note the location of the four firmware ROMs: A16U6, A16U7, A16U23, and A16U24. Refer to Figure 7-15.
4. Carefully pry the ROMs upward using a small-blade screwdriver. Pull the ROMs from their sockets evenly so that the IC pins (1) at the rear of each ROM are not bent.

### Replacement

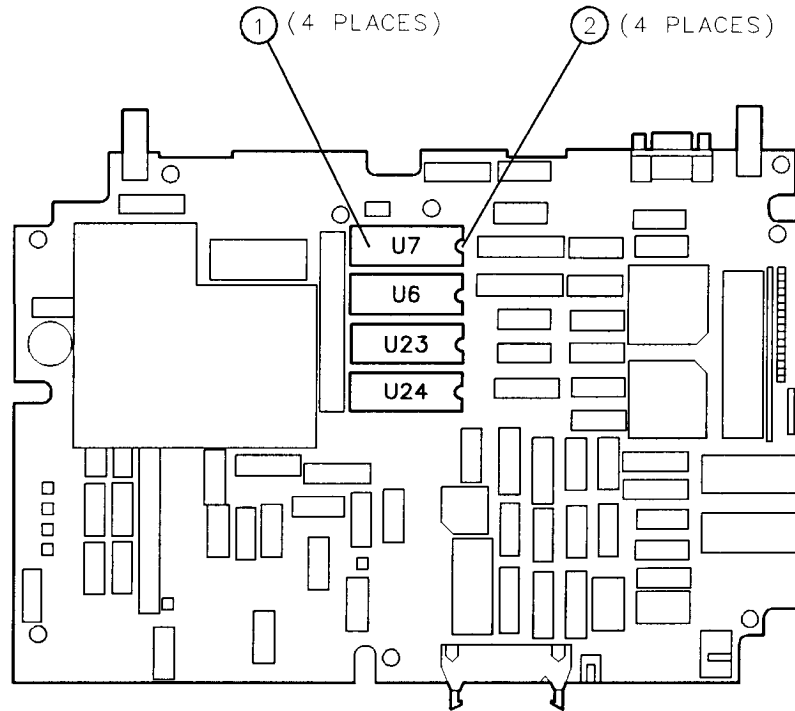
---

**Caution** To prevent damage to the ROMs, make sure that the ROMs are oriented correctly with the sockets on the A16 assembly. Match the notch (2) at the end of each ROM with the notch at the end of its socket. Align each ROM IC pin with the opening of its pin receptacle on the socket.

---

1. Position each ROM on the A16 assembly as illustrated in Figure 7-15.
2. Install each ROM by carefully pushing down on both ends of the ROM with equal pressure.
3. Replace the A25 Counter-Lock assembly. Refer to the “A25 Counter-Lock” replacement procedure.
4. Replace the instrument cover assembly. Refer to the “Instrument Cover” replacement procedure.
5. Continue at the “Adjustments Required after ROM Replacement” procedure.

## A16 Processor/Video Board Firmware ROMs



sq18ce1

**Figure 7-15. A16 Processor/Video Board Firmware ROM Replacement**

### Adjustments Required after ROM Replacement

1. Connect the instrument to ac power and turn the analyzer ON.
2. Press **PRESET**.
3. Let the analyzer warm up for 30 minutes.

---

**Note** A **FREQ UNCAL** message may appear on screen but will disappear after the successful completion of the self-calibration routines.

---

4. Perform the following adjustments from Chapter 2.
  - a. CAL FREQ Adjustment Routine
  - b. CAL AMPTD Adjustment Routine
  - c. CAL YTF Adjustment Routine (HP 8592L, 8593E, 8595E, and 8596E only)

---

## A16A1BT1 Battery

### This procedure applies to:

HP 8590 E-Series and L-Series spectrum analyzers  
HP 8591C cable TV analyzers  
HP 8594Q QAM analyzers

---

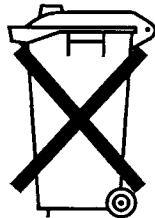
**Caution** Use ESD precautions when performing this replacement procedure.

---

---

**Warning** Battery A16A1BT1 contains lithium iodide. There is a danger of explosion if the battery is incorrectly replaced. Replace only with the same or equivalent type recommended. Do not incinerate or puncture this battery. Discard used batteries according to the manufacture's instructions.

---



DO NOT THROW BATTERIES AWAY BUT  
COLLECT AS SMALL CHEMICAL WASTE.

sk780a

---

## Removal/Replacement

---

**Caution** The A16A1 memory board assembly may be damaged if it is placed on a conductive surface. Use a static-safe workstation. Ensure that the memory board assembly is not placed on any conductive material.

---

1. Remove the A16A1 memory board assembly by lifting it up from the A16 processor/video board.

---

**Caution** Placing the bottom side of the A16A1 assembly on a conductive worksurface can result in loss of correction data stored in RAM. Protect the A16A1 assembly from contact with any conductive surface.

---

2. Remove the nylon insulator from the bottom of the A16A1 board assembly.
3. Locate the battery leads on the A16A1 assembly, desolder them, and remove the old battery.

---

**Note** A16A1C1 maintains the voltage required to back up RAM for a maximum of 8 hours. A16A1C1 is the large round capacitor next to A16A1BT1.

---

4. Replace and solder the leads of the new battery, ensuring proper polarity as silkscreened on the A16A1 board assembly.
5. Record the battery-replacement date on the battery label located on the analyzer rear frame.

## **A16A1BT1 Battery**

6. Replace the A16A1 memory board assembly onto the A16 processor/video board. Refer to the “A16 Processor/Video Board Assembly” replacement procedure.
7. Connect the power cord to the analyzer and turn the power on for about five minutes. This allows the supercap to fully charge and insures the battery switching circuitry is in the correct mode.

---

## A17 Memory Card Reader Assembly

### This procedure applies to:

HP 8590 E-Series and L-Series spectrum analyzers  
HP 8591C cable TV analyzers  
HP 8594Q QAM analyzers

### Removal

1. Remove the instrument cover assembly. Refer to the “Instrument Cover” removal procedure.
2. Place the analyzer on the worksurface with the bottom side facing up.
3. Disconnect the W14 ribbon cable (1) from the A17 Memory Card Reader assembly. See Figure 7-16.
4. Remove the jumper (5) between the A17 Memory Card Reader and LS1. See Figure 7-16.
5. Remove the two screws (2) that secure the A17 assembly to the chassis.

---

**Caution** When removing the A17 assembly, be sure to slide the assembly straight backward to prevent damage to the two alignment tabs on the front of the A17 support bracket.

---

6. Remove the A17 assembly (3), gently sliding the assembly towards the rear of the analyzer and up.
7. Remove the four screws (4) that secure the A17 assembly to the memory-card base and remove the A17 assembly.

### Replacement

1. Place the analyzer on the worksurface with the bottom side facing up.
2. Place the A17 Memory Card Reader assembly on the memory-card base.
3. Replace the four screws (4) that secure the A17 assembly to the memory-card base.

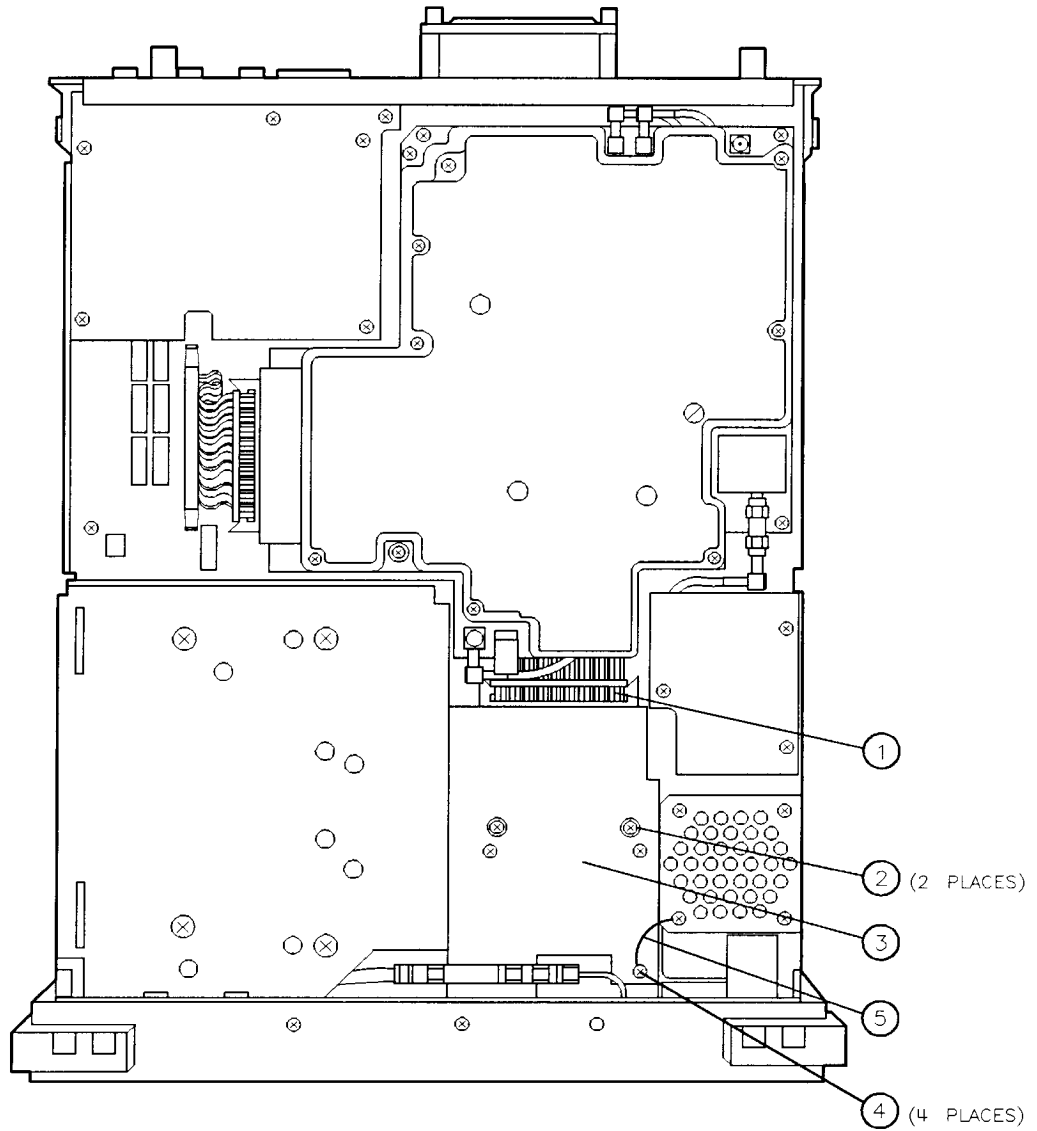
---

**Caution** The two alignment tabs on the memory-card base beneath the A17 Memory Card Reader assembly can be easily damaged. When replacing the A17 Memory Card Reader assembly, carefully mate the two alignment tabs with the memory-card bezel on the front-frame assembly.

---

4. Replace the A17 assembly (3), gently sliding the assembly along the chassis toward the memory-card reader bezel on the front-frame assembly.
5. Replace the two screws (2) that secure the A17 assembly to the chassis.
6. Replace the jumper (5) between the A17 Memory Card Reader and LS1.
7. Connect the W14 ribbon cable (1) to the A17 assembly.
8. Replace the instrument cover assembly. Refer to the “Instrument Cover” replacement procedure.

# A17 Memory Card Reader Assembly



sh264e

**Figure 7-16. A17 Memory Card Reader Replacement**

---

## A25 Counter-Lock Assembly

### This procedure applies to:

HP 8590 E-Series and L-Series spectrum analyzers  
HP 8591C cable TV analyzers  
HP 8594Q QAM analyzers

### Removal

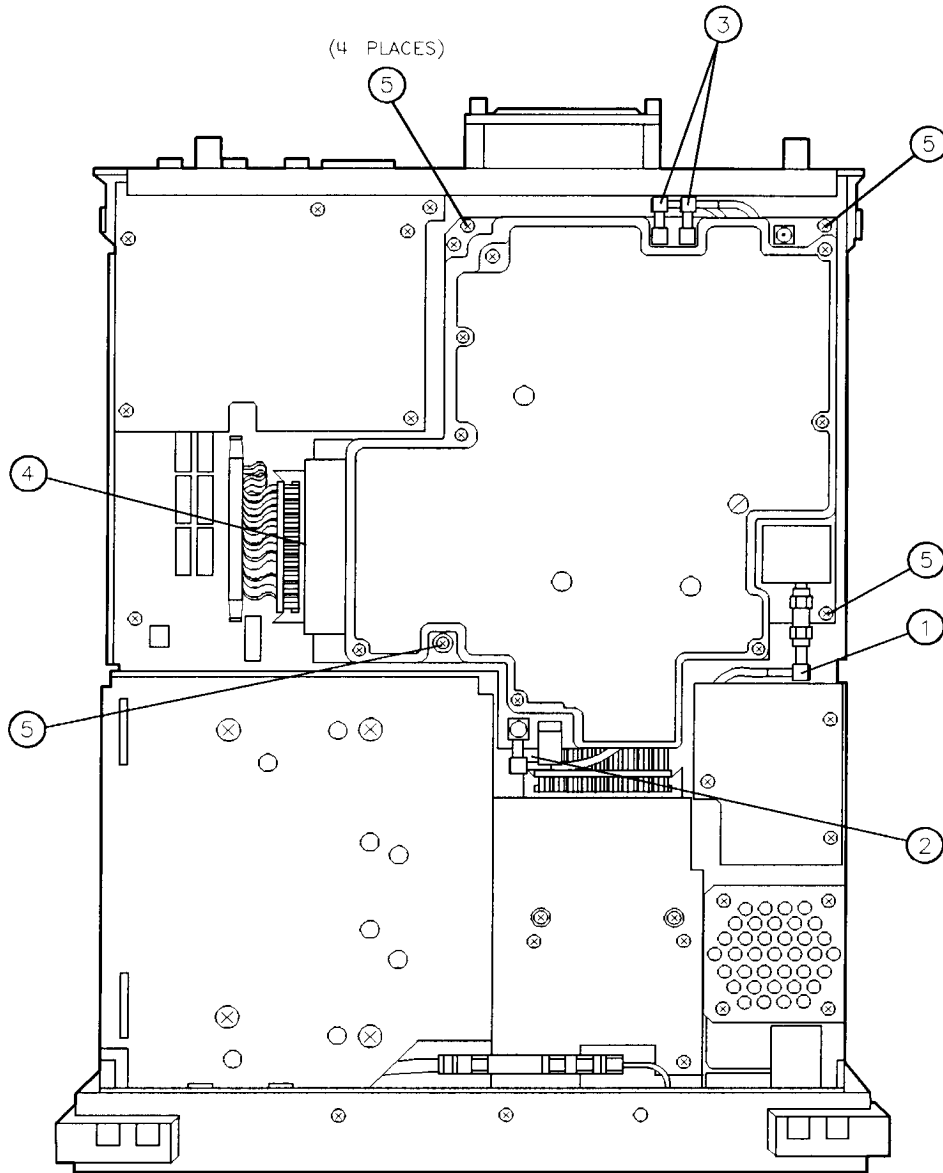
1. Remove the instrument cover assembly. Refer to the “Instrument Cover” removal procedure.
2. Place the analyzer on the worksurface with the bottom side facing up.
3. Disconnect W20 **(1)** from the counter-lock assembly. See Figure 7-17.
4. Disconnect the cables from A25J3 and A25J5 **(2)**.
5. Disconnect W4 **(4)** from the counter-lock assembly.
6. Remove the four mounting screws **(5)**.
7. As you remove the counter-lock assembly, disconnect the cables from A25J1 and A25J2 **(3)**.
8. Place the counter-lock in a static-safe container.

### Replacement

1. As you replace the counter-lock assembly, reconnect the cables to A25J1 and A25J2 **(3)**. See Figure 7-17.
2. Replace the four mounting screws **(5)**.
3. Connect W20 **(1)** to the counter-lock assembly.
4. Connect the cables to A25J3 and A25J5 **(2)**.
5. Connect W4 **(4)** to the counter-lock assembly.
6. Replace the instrument cover assembly. Refer to the “Instrument Cover” replacement procedure.



# A25 Counter-Lock Assembly



sh2125e

**Figure 7-17. A25 Counter-Lock Replacement**

# B1 Fan

This procedure applies to:

- HP 8590 E-Series and L-Series spectrum analyzers
- HP 8591C cable TV analyzers
- HP 8594Q QAM analyzers

## Removal

1. Disconnect the analyzer from ac power.
2. Place the instrument on the worksurface with the back end facing out.
3. Hold the B1 Fan assembly in position and loosen the four screws (1) that secure the fan assembly to the rear-frame assembly. See Figure 7-18.
4. Pull the fan 2 inches away from the instrument, reach into the opening in the rear frame, and disconnect the fan wiring from A15J19 (2).
5. Remove the four screws, washers, and spacers from the fan (1).
6. Remove the fan grill (3).

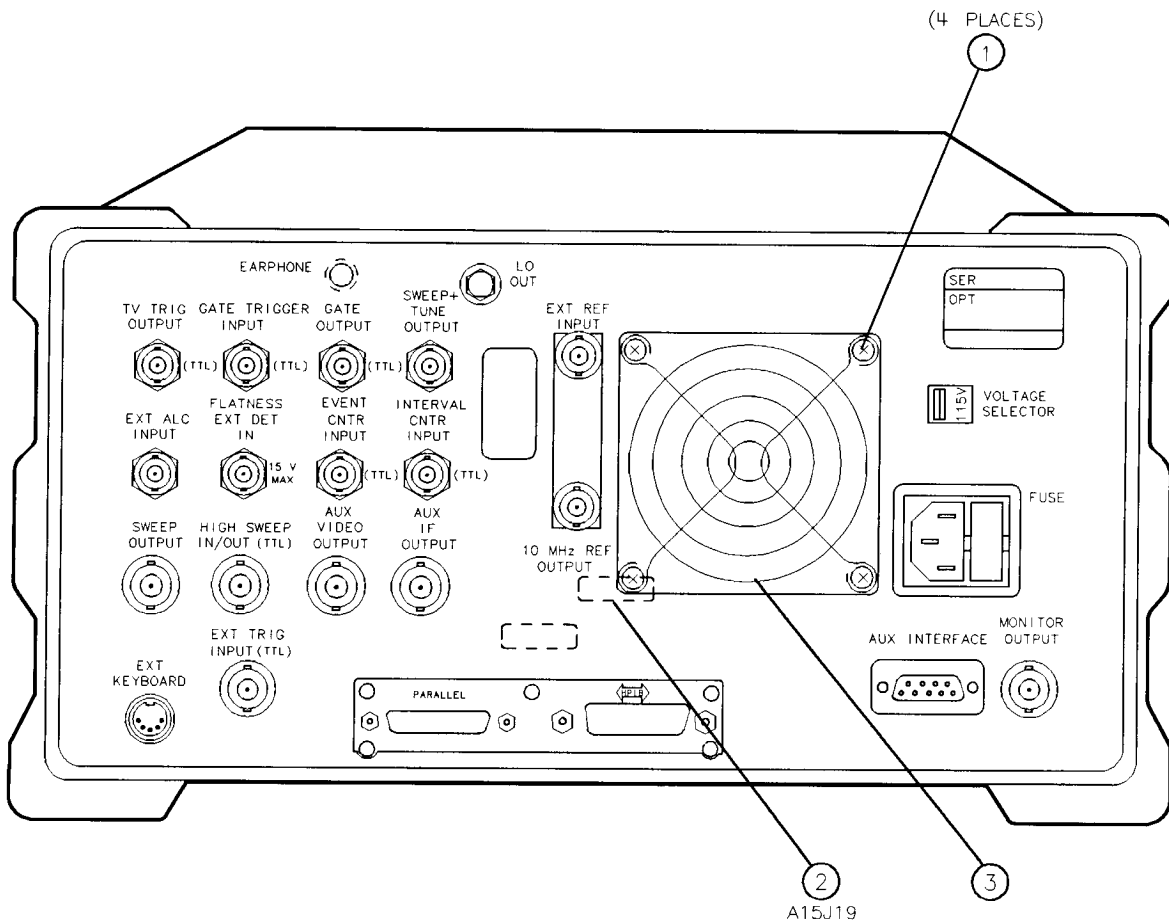


Figure 7-18. B1 Fan Replacement

## **Replacement**

1. Position the fan grill on the B1 Fan **(3)**. See Figure 7-18. The fan label must be visible through the fan grill to make sure that the fan provides the correct airflow.
2. Position the four spacers on the fan and replace the screws and washers **(1)**.
3. Hold the fan 2 inches away from the instrument and connect the fan wiring to A15J19 **(2)**.
4. Position the fan assembly on the instrument and tighten the four screws **(1)** that secure it to the rear frame.

---

## Rear-Frame Assembly

### This procedure applies to:

HP 8590 E-Series and L-Series spectrum analyzers  
HP 8591C cable TV analyzers  
HP 8594Q QAM analyzers

---

**Caution** Use ESD precautions when performing this replacement procedure.

---

### Removal

1. Remove the instrument cover assembly. Refer to the “Instrument Cover” removal procedure.
2. Place the analyzer with the top side facing up.
3. Remove the six screws (three on each side) that secure the rear frame to the main chassis.
4. Remove the W6 jumper from the 10 MHz REF OUTPUT and the EXT REF IN connectors.
5. Pull the rear frame straight back away from the main chassis.

---

**Note** Different models and option mixes will cause the configuration of the cables and wires to the rear frame to vary widely. Therefore, you will need to note these connections for reference during reassembly. See Figure 7-19.

---

6. Disconnect the fan assembly from J19 on the A15 IF Motherboard assembly.
7. Disconnect the wires and cables from the rear-frame assembly.

### Replacement

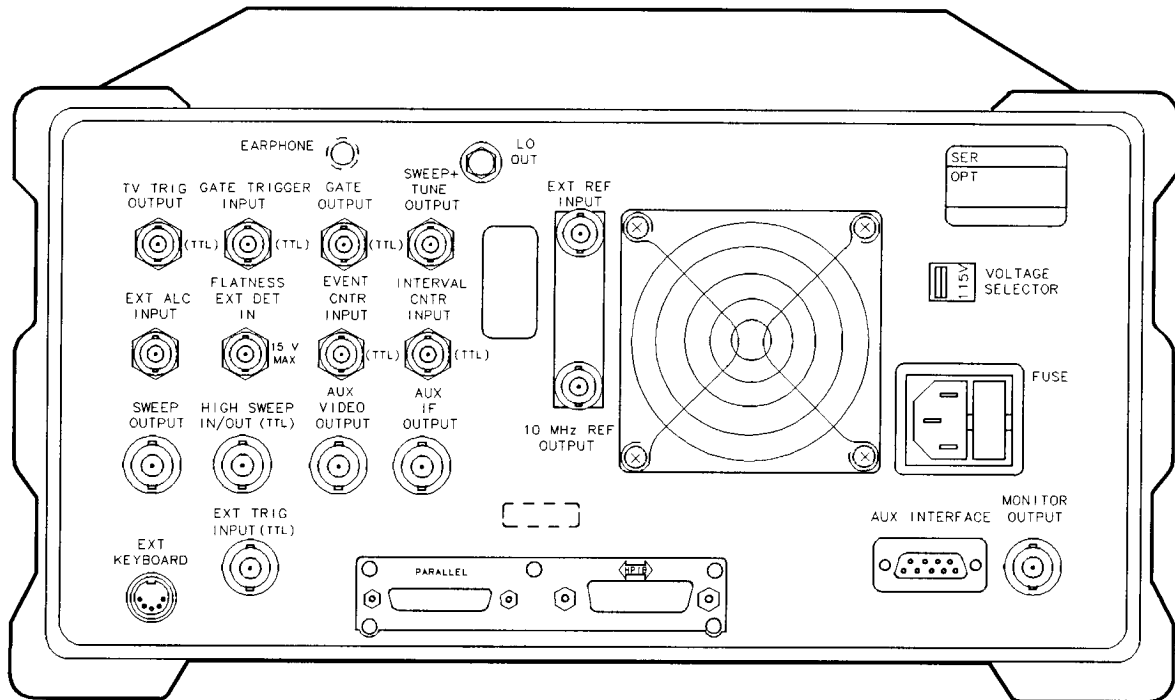
1. Connect the wires and cables to the rear-frame assembly as noted during the removal procedure. See Figure 7-19.
2. Connect the fan assembly to J19 on the A15 IF Motherboard assembly.

---

**Caution** Wiring can be pinched between the rear frame and the edge of the A15 motherboard. Make sure that all wiring is routed to one side of the SMB connector, A15J18, and through the notch located on the rear edge of the motherboard.

---

3. Place the rear frame on the main chassis.
4. Replace the W6 jumper between the 10 MHz REF OUTPUT and the EXT REF IN connectors.
5. Replace the six screws (three on each side) that secure the rear frame to the main chassis.
6. Replace the instrument cover assembly. Refer to the “Instrument Cover” replacement procedure.



sq15cel

Figure 7-19. Rear Frame Replacement

## Contacting Hewlett-Packard

---

If you have a problem with your analyzer, first, check the basics. This chapter contains a checklist that will help identify some of the most common problems. If further troubleshooting is necessary, refer to Chapter 4 in this guide or return the analyzer to Hewlett-Packard. This chapter is organized into the following sections:

**Check the Basics.**

A quick checklist to help identify some of the most common problems.

**Calling HP Sales and Service Offices.**

Refer to this section for information about contacting an HP sales and service office.

**Returning Your Analyzer for Service.**

Refer to this section for information about returning your analyzer for service.

---

## Check the Basics

Often problems may be solved by repeating what was being done when the problem occurred. A few minutes spent in performing these simple checks may eliminate time spent waiting for instrument repair.

- Check that the analyzer is plugged into the proper ac power source.
- Check that the line socket has power.
- Check that the rear-panel voltage selector switch is set correctly.
- Check that the line fuse is good.
- Check that the analyzer is turned on.
- Check that the other equipment, cables, and connectors are connected properly and operating correctly.
- Check the equipment settings in the procedure that was being used when the problem occurred.
- Check that the test being performed and the expected results are within the specifications and capabilities of the analyzer. Refer to the calibration guide for your instrument.
- Check the analyzer display for error messages. Refer to the *HP 8590 E-Series and L-Series Spectrum Analyzers User's Guide* or *HP 8591C Cable TV Analyzer User's Guide, Spectrum Analyzer Reference*.
- Check operation by performing the verification procedures in the calibration guide for your instrument. Record all results in the Performance Test record.

If there is still a problem, refer to Chapter 4 in this book.

## Calling HP Sales and Service Offices

Use the information in this section to obtain Hewlett-Packard sales and service offices information. Sales and service offices are located around the world to provide complete support for your analyzer. To obtain servicing information or to order replacement parts, contact the nearest Hewlett-Packard sales and service office listed in Table 8-1. In any correspondence or telephone conversations, refer to the analyzer by its model number and full serial number. With this information, the HP representative can quickly determine whether your unit is still within its warranty period.

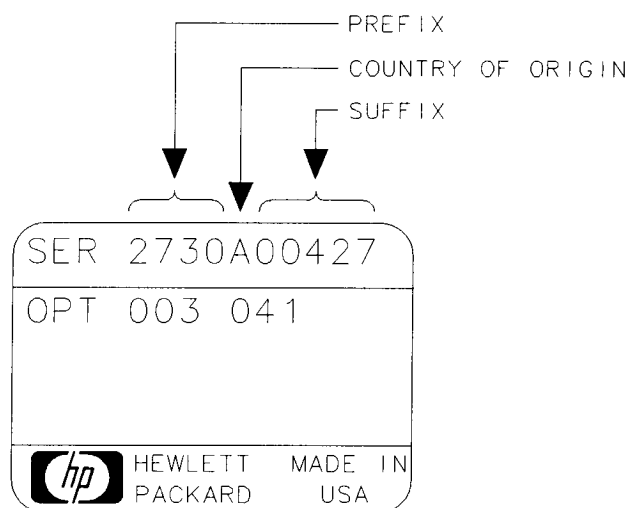
### Instrument serial numbers

Hewlett-Packard makes frequent improvements to its products to enhance their performance and reliability. Hewlett-Packard service personnel have access to the records of design changes for each instrument, based on the instrument's serial number and option designation.

Whenever you contact Hewlett-Packard about your analyzer, have a complete serial number. This will ensure that you obtain accurate service information.

A serial-number label is attached to the rear of the analyzer. This label has two instrument identification entries: the first provides the instrument's serial number and the second provides the identification number for each option built into the instrument.

The serial number is divided into three parts. The first four digits are the serial-number prefix; the letter indicates the country of origin; the last five digits are the suffix. The serial-number label contains a three-digit option number for each option built into the analyzer. Each option number is entered sequentially below the serial number. See Figure 8-1.



sq14e

**Figure 8-1. Typical Serial-Number Label**

The serial-number prefix is a code that identifies the date of the last major design change that is built into the analyzer. The letter identifies the country where the instrument was manufactured. The five-digit suffix is a sequential number and is different for each instrument.



## **Before calling Hewlett-Packard**

Before calling Hewlett-Packard or returning the analyzer for service, please make the checks listed in "Check the Basics". If you still have a problem, please read the warranty printed at the front of this guide. If your analyzer is covered by a separate maintenance agreement, please be familiar with its terms.

Hewlett-Packard offers several maintenance plans to service your analyzer after warranty expiration. Call your HP sales and service office for full details.

If you want to service the analyzer yourself after warranty expiration, refer to Chapter 4 in this guide.

## **HP sales and service offices**

Refer to the following table for HP sales and service office telephone and address information.

**Table 8-1. Hewlett-Packard Sales and Service Offices**

UNITED STATES		
<p><b>Instrument Support Center</b>                      Hewlett-Packard Company                      (800) 403-0801</p>		
EUROPEAN FIELD OPERATIONS		
<p><b>Headquarters</b>                      Hewlett-Packard S.A.                      150, Route du Nant-d'Avril                      1217 Meyrin 2/Geneva                      Switzerland                      (41 22) 780.8111</p>	<p><b>France</b>                      Hewlett-Packard France                      1 Avenue Du Canada                      Zone D'Activite De Courtaboeuf                      F-91947 Les Ulis Cedex                      France                      (33 1) 69 82 60 60</p>	<p><b>Germany</b>                      Hewlett-Packard GmbH                      Hewlett-Packard Strasse                      61352 Bad Homburg v.d.H                      Germany                      (49 6172) 16-0</p>
<p><b>Great Britain</b>                      Hewlett-Packard Ltd.                      Eskdale Road, Winnersh Triangle                      Wokingham, Berkshire RG41 5DZ                      England                      (44 734) 696622</p>		
INTERCON FIELD OPERATIONS		
<p><b>Headquarters</b>                      Hewlett-Packard Company                      3495 Deer Creek Road                      Palo Alto, California, USA                      94304-1316                      (415) 857-5027</p>	<p><b>Australia</b>                      Hewlett-Packard Australia Ltd.                      31-41 Joseph Street                      Blackburn, Victoria 3130                      (61 3) 895-2895</p>	<p><b>Canada</b>                      Hewlett-Packard (Canada) Ltd.                      17500 South Service Road                      Trans-Canada Highway                      Kirkland, Quebec H9J 2X8                      Canada                      (514) 697-4232</p>
<p><b>China</b>                      China Hewlett-Packard Company                      38 Bei San Huan X1 Road                      Shuang Yu Shu                      Hai Dian District                      Beijing, China                      (86 1) 256-6888</p>	<p><b>Japan</b>                      Hewlett-Packard Japan, Ltd.                      9-1 Takakura-Cho, Hachioji                      Tokyo 192, Japan                      (81 426) 60-2111</p>	<p><b>Singapore</b>                      Hewlett-Packard Singapore (Pte.) Ltd.                      150 Beach Road                      #29-00 Gateway West                      Singapore 0718                      (65) 291-9088</p>
<p><b>Taiwan</b>                      Hewlett-Packard Taiwan                      8th Floor, H-P Building                      337 Fu Hsing North Road                      Taipei, Taiwan                      (886 2) 712-0404</p>		

---

## Returning Your Analyzer for Service

Use the information in this section if you need to return the analyzer to Hewlett-Packard.

### Package the analyzer for shipment

Use the following steps to package the analyzer for shipment to Hewlett-Packard for service:

1. Fill in a service tag (available at the end of this chapter) and attach it to the instrument. Please be as specific as possible about the nature of the problem. Send a copy of any or all of the following information:
  - Any error messages that appeared on the analyzer display.
  - A completed Performance Test record from the calibration guide for your instrument.
  - Any other specific data on the performance of the analyzer.

---

**Caution** Analyzer damage can result from using packaging materials other than those specified. Never use styrene pellets in any shape as packaging materials. They do not adequately cushion the instrument or prevent it from shifting in the carton. Styrene pellets cause equipment damage by generating static electricity and by lodging in the analyzer fan.

---

2. Use the original packaging materials or a strong shipping container that is made of double-walled, corrugated cardboard with 159 kg (350 lb) bursting strength. The carton must be both large enough and strong enough to accommodate the analyzer and allow at least 3 to 4 inches on all sides of the analyzer for packing material.
3. Surround the instrument with at least 3 to 4 inches of packing material, or enough to prevent the instrument from moving in the carton. If packing foam is not available, the best alternative is SD-240 Air Cap™ from Sealed Air Corporation (Commerce, CA 90001). Air Cap looks like a plastic sheet covered with 1-1/4 inch air-filled bubbles. Use the pink Air Cap to reduce static electricity. Wrap the instrument several times in the material to both protect the instrument and prevent it from moving in the carton.
4. Seal the shipping container securely with strong nylon adhesive tape.
5. Mark the shipping container "FRAGILE, HANDLE WITH CARE" to ensure careful handling.
6. Retain copies of all shipping papers.

## Assembly Descriptions and Block Diagrams

---

This chapter describes the operation of the HP 8590 E-Series and L-Series spectrum analyzers, HP 8591C cable TV analyzers and HP 8594Q QAM analyzers that is useful when first troubleshooting an analyzer failure.

Component-level information for the HP 8590 E-Series and L-Series spectrum analyzers, HP 8591C cable TV analyzers, and HP 8594Q QAM analyzers is provided in the *HP 8590 Series Analyzers Component-Level Repair Service Guide*. Refer to Chapter 12 for a list of available component-level service information.

The HP 8590 E-Series and L-Series spectrum analyzers, HP 8591C cable TV analyzers, and HP 8594Q QAM analyzers are microprocessor-controlled swept receivers covering the following frequency ranges. The overall description briefly describes each of the major analyzer assemblies.

**Table 9-1.**  
**HP 8590 E-Series and L-Series Spectrum Analyzer, HP 8591C Cable TV Analyzer, and HP 8594Q QAM Analyzer Frequency Ranges**

Analyzer Model	Frequency Range
HP 8590L	9 kHz to 1.8 GHz
HP 8591C	1 MHz to 1.8 GHz
HP 8591E	9 kHz to 1.8 GHz
HP 8592L	9 kHz to 22.0 GHz
HP 8592L (Option 026)	9 kHz to 26.5 GHz
HP 8592L (Option 027)	9 kHz to 26.5 GHz
HP 8593E	9 kHz to 22.0 GHz
HP 8593E (Option 026)	9 kHz to 26.5 GHz
HP 8593E (Option 027)	9 kHz to 26.5 GHz
HP 8594E	9 kHz to 2.9 GHz
HP 8594L	9 kHz to 2.9 GHz
HP 8594Q	9 kHz to 2.9 GHz
HP 8595E	9 kHz to 6.5 GHz
HP 8596E	9 kHz to 12.8 GHz

---

## RF and LO Section for HP 8590L, HP 8591E, and HP 8591C Spectrum Analyzers

This section describes the operation of the A3 front-end assembly and the A25 counterlock assembly for the HP 8590L and HP 8591E spectrum analyzers and HP 8591C cable TV analyzers. The related operation of the A7 analog interface assembly and the A9 Third Converter are also described. Each block of text describes an analyzer assembly designated by its reference designator. For details about the operation of the HP 8590L, HP 8591C, and HP 8591E RF section, refer to Foldout 9-2, located at the end of this chapter.

The RF front-end section uses triple conversion to convert RF signals to the final 21.4 MHz IF frequency.

### J1 Input Connector

The analyzer RF section receives input signals via a 50  $\Omega$  input, or 75  $\Omega$  input. To protect the attenuator and input mixer from damage, refer to "Analyzer Input Protection" in Chapter 1 for maximum input level requirements.

### A3 Input Attenuator

The A3 input attenuator has a 0 to 60 dB range that provides input attenuation in 10 dB steps. Pressing **PRESET** or analyzer power-on selects 10 dB attenuation. If **POWERON LAST** is selected, the analyzer is reset to the settings in use when the analyzer was turned off.

### A4 First Converter

The A4 first converter assembly converts incoming signals to a 2.1214 GHz first IF by mixing the 2.1214 GHz to 3.9214 GHz LO signal from the A6 YTO assembly with the input signal. The first IF signal is the summed signal from the mixing process. For analyzers that are not equipped with a tracking generator, Option 010 or Option 011, the J4 output for the tracking generator is terminated.

### FL1 Low-Pass Filter and AT1 Isolator

The first IF signal is routed through FL1, a 4.9 GHz low-pass filter, and the AT1 isolator. The devices limit unwanted mixing products and isolate the A4 first converter from the A5 second converter.

### A5 Second Converter

The 2.1214 GHz first IF signal is downconverted by the A5 second converter to a 321.4 MHz second IF. This is accomplished by mixing the first IF signal with the 1.8 GHz second LO signal. The second LO signal is produced by multiplying the 600 MHz signal from the A9 Third Converter by three.

The 2.1212 GHz bandpass filter is a high Q filter that eliminates unwanted mixing products. Its performance is due to the resonant characteristics of three precisely machined cavities in an aluminum block.

The 321.4 MHz matching filter is an adjustable bandpass filter that prevents unwanted mixing products from passing on to the A9 third converter.

## A9 Third Converter

The A9 third converter performs five functions:

1. Produces the 300 MHz CAL OUT signal. The CAL OUT signal is rich in harmonics; these are required for the CAL\_FREQ self-calibration routine.
2. Provides the 600 MHz reference to the multiplier on the A5 second converter assembly.
3. Sends a 300 MHz signal to the A25 counterlock assembly. The A25 assembly locks the 300 MHz signal to the 10 MHz frequency reference. Note that this step applies to all HP 8591C, HP 8591E and HP 8590L analyzers.
4. Converts the 321.4 MHz IF signal to the final 21.4 MHz IF signal.
  - The 321.4 MHz IF signal is first amplified and filtered by the 321.4 MHz bandpass filter.
  - The 600 MHz reference is divided to produce the 300 MHz third LO.
  - The filtered 321.4 MHz IF signal and the 300 MHz third LO mix at the third mixer, a double-balanced mixer, to produce the 21.4 MHz IF.
  - The 21.4 MHz IF passes through a 21.4 MHz bandpass filter, a buffer amplifier with a nominal 19 dB of gain, and a variable IF calibration amplifier. The variable amplifier has a gain range of  $-15$  to  $+2$  dB.
5. Changes the amplitude of the 21.4 MHz IF signal to calibrate the analyzer during the CAL\_AMPTD self-calibration routine.
  - The amplitude of the detected 21.4 MHz IF signal is measured on the A16 processor/video assembly.
  - The A7 analog interface assembly adjusts the gain of the IF calibration amplifier based on the A16 amplitude measurement.
  - The CAL\_AMPTD adjustment routine adjusts the output of the A9 IF calibration amplifier for a displayed amplitude of  $-20$  dBm at 300 MHz. The analyzer is set for a reference level of  $-20$  dBm and a center frequency of 300 MHz. (The calibration routine uses the CAL OUT signal.)

## 10 MHz Frequency Reference

Note that this section applies to all HP 8591C, HP 8591E, and HP 8590L analyzers.

The 10 MHz frequency reference is used to phase-lock the 600 MHz oscillator on the A9 third converter. There are two frequency references available:

- The standard 10 MHz room temperature crystal oscillator (RTXO).
- The precision frequency reference (PFR), A22, is a 10 MHz oven-controlled crystal oscillator (OCXO).

## A25 Counterlock

The A25 counterlock assembly performs four main functions:

- Phase-locks the 600 MHz SAW oscillator on the A9 third converter to the 10 MHz reference.
- Counts the first LO frequency.
- Provides discriminator output, DISCRIM, to the A7 analog interface assembly.
- Counts the 21.4 MHz IF.

Refer to Foldout 9-5, at the end of this chapter for details about the operation of the A25 counterlock assembly.

On the A9 third converter, the output of the 600 MHz oscillator is divided by two and the resulting 300 MHz signal is routed to the A25 counterlock assembly. The A25 counterlock assembly divides the 300 MHz signal by 40 to generate a 7.5 MHz reference for the sampling oscillator, stabilizer, and frequency counter. The 7.5 MHz reference and the 10 MHz reference are divided further and compared in a phase-frequency detector. The output of the phase-frequency detector, VTO\_TUNE, is fed back to A9 to tune the 600 MHz oscillator.

The sampling oscillator provides a 279 to 298 MHz driving signal to the A25A1 sampler. The first LO signal is also applied to A25A1 sampler. The first LO signal is mixed with a harmonic of the sampling oscillator signal to generate the sampler IF. This IF is divided by 10 and fed to one input of the frequency counter. The equation used to produce the first LO frequency is:

$$\text{1st LO Frequency} = N \times F_{SO} + \text{Sampler IF}$$

$N$  represents the harmonic of the sampling oscillator.

$F_{SO}$  represents the sampling oscillator frequency.

*Sampler IF* represents the counted sampler IF (may be negative).

The stabilizer mixes the divided sampler IF (nominally 8.25 MHz) with the 7.5 MHz, and feeds the difference signal into the discriminator. The discriminator output, DISCRIM, is fed back to the A7 analog interface assembly to tune the A3A7 YTO precisely to the center frequency.

When the frequency count marker is active, the analyzer pauses at the marked frequency and counts the first LO as described previously. The 21.4 MHz IF is then divided by four, to a nominal value of 5.35 MHz, fed to another frequency counter input, and counted. With the second LO, the third LO, the counted first LO, and the counted final IF all referenced to the 10 MHz reference, the actual input signal frequency is calculated.

## A25A1 Sampler

The A25A1 sampler mixes the first LO with a harmonic of the sampling oscillator to produce the 76 MHz to 89 MHz sampler IF output. In the phase-locking process, the sampler IF is counted and the YTO tune DACs on the A7 analog interface assembly are adjusted until the actual sampler IF frequency is equal to the desired sampler IF. In YTO spans of 10 MHz or less, the sampler IF is also applied to a discriminator. The output of the discriminator (DISCRIM) fine-tunes the YTO precisely to the center frequency.

## **A6 YIG Tuned Oscillator (YTO)**

The A6 YTO contains a YIG (yttrium-iron-garnet) which is a ferro-magnetic material polished into a small sphere and precisely oriented in a magnetic field. The A7 analog interface assembly provides the control current that alters the magnetic field to generate the required YTO frequency.

The YTO provides the 2.1214 GHz to 3.9214 GHz first LO. The YTO output is sent to a power splitter in the A4 first converter assembly. The power splitter routes the first LO signal to the first mixer and the A25A1 sampler.

## **A7 Analog Interface**

The A7 analog interface assembly receives digital control input on the I/O bus control lines from the A16 processor/video assembly, and produces analog control signals for most of the analyzer functions. This section describes several of the control functions illustrated on Foldout 9-1.

The A7 analog interface assembly provides control voltages for the Sweep Generator and Span Dividers:

- The SWEEP RAMP output is 0 to +10 V.
- The RAMP output is –10 V to +10 V for any span.
- Two SPAN signals, MAIN SPAN and FM SPAN, are generated by attenuating the RAMP signal. The MAIN SPAN and FM SPAN signals are fed to the YTO drivers to sweep the YTO frequency. The amplitude of the SPAN signals depends on the span setting selected.

If the LO span is greater than 10 MHz, then the MAIN SPAN signal is used.

If the LO span is less than or equal to 10 MHz, then the FM SPAN signal is used.

The A7 analog interface assembly controls the center frequency of the YTO:

- The YTO tune DACs in the A7 YTO driver circuitry determine the center frequency of the YTO.
- For LO spans greater than 10 MHz, the MAIN SPAN signal is summed with the output of the YTO tune DAC in the YTO main coil driver.
- For LO spans less than or equal to 10 MHz, the FM SPAN signal is summed with the A25 DISCRIM signal in the FM coil driver. The DISCRIM signal is used to lock the YTO precisely to the center frequency.
- The control voltages produced using either SPAN signal are then converted to currents that drive the A6 YTO.



---

## RF and LO Section for HP 8592L, HP 8593E, HP 8594E, HP 8594L, HP 8594Q, HP 8595E, and HP 8596E Analyzers

The HP 8592L, HP 8593E, HP 8594E, HP 8594L, HP 8594Q, HP 8595E, and HP 8596E analyzer RF and LO section includes the following assemblies:

- A3A1 comb generator (except HP 8595E)
- A3A2 RF switch (HP 8592L and HP 8593E only)
- A3A3 2.9 GHz LPF
- A3A4 second converter
- A3A5 input attenuator
- A3A6 dual-band mixer (low-band mixer for HP 8594E, HP 8594L, and HP 8594Q)
- A3A8 YTF (YIG-tuned Filter) (except HP 8594E, HP 8594L, and HP 8594Q)
- A3A8 SYTF (Switched YIG-tuned filter) (HP 8595E and HP 8596E only)
- A3A9 321.4 MHz low-pass filter
- A3A11 step recovery diode
- A3A12 3 dB pad
- A3A15 tracking generator (Option 010)
- A7 analog interface
- A9 third converter
- FL1 3.9214 GHz low-pass filter

For details about the operation of the HP 8592L, HP 8593E, HP 8594E, HP 8594L, HP 8594Q, HP 8595E, and HP 8596E, RF section, refer to Foldouts 9-3 and 9-4, located in the back of this chapter.

The RF section converts all input signals to a fixed 21.4 MHz IF. The microcircuits in the RF section are controlled by signals from the A7 analog interface assembly. The A7 analog interface assembly also includes circuitry for controlling the LO and IF sections.

Five frequency bands cover the HP 8592L, HP 8593E, HP 8594E, HP 8594L, HP 8594Q, HP 8595E, and HP 8596E spectrum analyzers input range.

Band	Frequency Range	Analyzer Model
0	9 kHz to 2.9 GHz	HP 8592L, 93E, 94E, 94L, 94Q, 95E, 96E
1	2.75 to 6.5 GHz	HP 8592L, 93E, 95E, 96E
2	6.0 to 12.8 GHz	HP 8592L, 93E, 96E
3	12.4 to 19.4 GHz	HP 8592L, 93E
4	19.1 to 22 (except Option 026 and 027)	HP 8592L, 93E
4	19.1 to 26.5	HP 8592L, 93E (Option 026 and 027)

Band 0 (low band) uses triple conversion to produce the final 21.4 MHz IF. The A3A6 dual band mixer up-converts the RF input to a 3.9214 GHz first IF. The A3A4 second converter down-converts the 3.9214 GHz first IF to a 321.4 MHz second IF. The A9 third converter down-converts the second IF to the final 21.4 MHz IF.

Bands 1 through 4 (high bands) use double conversion. The A3A6 dual-band mixer down-converts the RF input to a 321.4 MHz first IF. Although this first IF passes through the A3A4 second converter, it bypasses the second mixer. The second and final conversion occurs in the A9 third converter where the first IF is down-converted to produce the final 21.4 MHz IF.

## **LO Section for the HP 8593E, HP 8594E, HP 8594L, HP 8594Q, HP 8595E, and HP 8596E Analyzers**

The LO Section includes the following assemblies:

- A3A7 YTO (YIG-Tuned Oscillator)
- A3A10 directional coupler
- A3A13 isolator
- A7 analog interface
- A9 third converter
- A22 precision frequency reference
- A25 counterlock (not available for the HP 8592L)
- AT1 10 dB pad

Refer to Foldout 9-5 at the end of this chapter for details about the operation of the LO section.

The LO section provides a 3.0 to 6.8214 GHz first LO, a 600 MHz second LO, a 300 MHz third LO, a 300 MHz CAL OUT signal, and an IF frequency counter. The counter and the local oscillators use one of two 10 MHz frequency references: the standard room temperature crystal oscillator (RTXO) or the A22 precision frequency reference, oven-controlled crystal oscillator (OCXO).

The 10 MHz reference phase-locks the 600 MHz oscillator on the A9 third converter. The 600 MHz signal drives the second converter and is divided to produce the 300 MHz third LO and CAL OUT signals. A 300 MHz signal that is sent to the A25 counterlock assembly is divided down further to produce a 7.5 MHz reference signal. This 7.5 MHz reference is used by the stabilizer, the sampling oscillator, and frequency counter. The phase-frequency detector is located on the A25 counterlock assembly.

The first LO output of the A3A7 YTO is fed through the A3A13 isolator to the A3A10 directional coupler. The main output of the coupler is sent to the A3A6 dual-band mixer (low-band mixer for the HP 8594E and HP 8594Q). The coupled output is fed through the AT1 10 dB pad to the A25A1 sampler. The sampler mixes the first LO with a harmonic of the sampling oscillator to generate a 60 to 100 MHz sampler IF. This value is then divided by 10, producing a 6 to 10 MHz output.

During retrace, the YTO is locked to the selected first LO frequency. The divided sampler IF is then counted in the frequency counter. The YTO tune DACs on the A7 analog interface assembly are adjusted until the counted frequency is equal to the desired frequency. In LO spans less than or equal to 10 MHz, the divided sampler IF is also fed to a stabilizer, which generates the DISCRIM (discriminator) signal. DISCRIM tunes the YTO precisely to the desired first LO frequency.

When a trigger signal occurs, a sweep ramp is applied to the main coil drivers while in LO spans greater than 10 MHz, or to the FM coil drivers while in LO spans less than or equal to 10 MHz. During a main coil sweep, the sampling oscillator is disconnected from the A25A1 sampler.

In frequency count mode, the first LO sweeps up to the marked signal and pauses. The divided sampler IF is counted to calculate the actual first LO frequency. Then the prescaled 21.4 MHz IF, nominally 5.35 MHz, is counted and the actual input frequency calculated.

## **A9 Third Converter Assembly**

The A9 Third Converter performs the following functions:

- Down-converts the 321.4 MHz IF to the final 21.4 MHz IF.
- Generates the 300 MHz third LO.
- Provides variable gain from the calibrator amplifier that adjusts the amplitude of the 21.4 MHz IF during the analyzer CAL AMPTD self-calibration routine.
- Generates the 600 MHz second LO drive signal for the A3A4 second converter assembly and for the tracking generator (Option 010).
- Generates the 300 MHz CAL OUT signal at  $-20$  dBm.
- Provides a buffered 300 MHz to drive the external reference PLL circuitry on the A25 counterlock assembly.

Refer to Foldout 9-6 at the end of this chapter for details about the operation of the A9 third converter assembly.

Refer to “Troubleshooting the A15 Motherboard Assembly” in Chapter 5 when tracing control signals for the A9 third converter assembly.

The output of the 600 MHz surface acoustical wave (SAW) oscillator is buffered, providing the second LO signal to the A3A4 second converter. This signal is further buffered, divided by two, and buffered again to produce three 300 MHz outputs. A second 600 MHz output drive signal is available for the tracking generator (Option 010).

The amplitude of the 300 MHz signal from the calibrator amplifier is adjusted to provide the  $-20$  dBm output for the 300 MHz CAL OUT signal. This amplifier produces rich harmonics that are used in the analyzer self-calibration routines.

The 300 MHz signal sent to the 300 MHz Buffer produces the other two 300 MHz outputs:

- The 300 MHz third LO sent to the mixer/filter.
- The 300 MHz feedback signal sent to the A25 counterlock assembly by the counterlock buffer. This signal is divided down and compared to the 10 MHz reference in a phase/frequency detector on the A25 counterlock assembly. The output of the phase/frequency detector, VTO\_TUNE, is fed back to the 600 MHz SAW Oscillator to increase its frequency stability.

The 321.4 MHz second IF signal from the A3A4 second converter is amplified and bandpass-filtered on the A9 third converter assembly. This signal is mixed with the 300 MHz third LO to produce the 21.4 MHz difference signal that is then bandpass-filtered and buffered.

The buffered 21.4 MHz IF signal is amplified in the IF calibration amplifier (IF Cal Amp). The gain of the calibration amplifier is controlled by a DAC on the A7 analog interface assembly via the REF\_LVL\_CAL control line. During the CAL\_AMPTD routine, the gain of the calibration amplifier is adjusted so that the reference level at top-screen is calibrated. The amplitude reference for the routine is provided by the -20 dBm CAL\_OUT signal with 10 dB of input attenuation in band 0. Refer to "IF Power-Level Measurement" in Chapter 5 for more information about the 21.4 MHz output from the A9 third converter assembly.

## **A25 Counterlock Assembly**

The A25 counterlock assembly performs four main functions:

- Phase-locks the 600 MHz SAW oscillator on the A9 third converter to the 10 MHz reference.
- Counts the first LO frequency.
- Provides discriminator output, DISCRIM, to the A7 analog interface assembly.
- Counts the 21.4 MHz IF.

Refer to Foldout 9-5, at the end of this chapter for details about the operation of the A25 counterlock assembly.

On the A9 third converter, the output of the 600 MHz oscillator is divided by two and the resulting 300 MHz signal is routed to the A25 counterlock assembly. The A25 counterlock assembly divides the 300 MHz signal by 40 to generate a 7.5 MHz reference for the sampling oscillator, stabilizer, and frequency counter. The 7.5 MHz reference and the 10 MHz reference are divided further and compared in a phase-frequency detector. The output of the phase-frequency detector, VTO\_TUNE, is fed back to A9 to tune the 600 MHz oscillator.

The sampling oscillator provides a 279 to 298 MHz driving signal to the A25A1 sampler. The first LO signal is also applied to A25A1 sampler. The first LO signal is mixed with a harmonic of the sampling oscillator signal to generate the sampler IF. This IF is divided by 10 and fed to one input of the frequency counter. The equation used to produce the first LO frequency is:

$$\text{1st LO Frequency} = N \times F_{SO} + \text{Sampler IF}$$

$N$  represents the harmonic of the sampling oscillator.

$F_{SO}$  represents the sampling oscillator frequency.

*Sampler IF* represents the counted sampler IF (may be negative).

The stabilizer mixes the divided sampler IF (nominally 8.25 MHz) with the 7.5 MHz, and feeds the difference signal into the discriminator. The discriminator output, DISCRIM, is fed back to the A7 analog interface assembly to tune the A3A7 YTO precisely to the center frequency.

When the frequency count marker is active, the analyzer pauses at the marked frequency and counts the first LO as described previously. The 21.4 MHz IF is then divided by four, to a nominal value of 5.35 MHz, fed to another frequency counter input, and counted. With the second LO, the third LO, the counted first LO, and the counted final IF all referenced to the 10 MHz reference, the actual input signal frequency is calculated.

### **A3A14 First LO Distribution Amplifier (LODA) for Option 009 or 010**

The A3A14 first LO distribution amplifier, (LODA), amplifies and levels the first LO signal from the A3A7 YTO and distributes it to the A25A1 sampler (through attenuator AT1), A3A8 dual band mixer, and A3A15 tracking generator. The leveling control circuitry is on the A10 tracking generator control assembly.

The LODA consists of a PIN diode attenuator, an amplifier, three directional couplers, a buffer amplifier, and a detector. Refer to Foldouts 9-2 and 9-3. All three directional couplers are connected in series. The main line of the directional couplers is the output to the A3A15 tracking generator assembly. The directional coupler outputs feed the A3A6 dual-band mixer, the detector, and the buffer amplifier for driving the A25A1 sampler.

The detector output is fed to the A10 tracking generator control assembly. Here it is fed into a loop integrator. The reference voltage for the loop integrator is adjustable and determines the output power of the LODA. The gate bias adjustment is also on A10. Note that the LODA drive circuit common is connected only to the A3A14 LODA itself and not to any other grounds on A10.

Refer to Foldout 9-5, for details about the operation of the A3A14 assembly.

### **A3A15 Tracking Generator for Option 010**

The A3A15 tracking generator assembly consists of several smaller circuits. The A3A15 tracking generator assembly is not component-level repairable; a rebuilt exchange assembly is available.

The tracking generator recreates only one of the analyzer intermediate frequencies. This minimizes isolation problems associated with a built-in tracking generator. Each of the blocks of the A3A15 tracking generator assembly is described below.

## **Tracking Oscillator**

The tracking oscillator enables the fine adjustment of the tracking generator output frequency to compensate for the frequency inaccuracies of the analyzer 21.4 MHz IF. The tracking oscillator determines the residual FM and frequency drift of the tracking generator. The 184.28 MHz output frequency is obtained by doubling the output of a crystal oscillator operating at 92.14 MHz.

## **Upconverter**

The upconverter mixes the tracking oscillator output with the buffered 600 MHz reference from the A9 third converter assembly. The upconverter also contains a filter to pass only the 784.28 MHz upper sideband.

## **Pentupler**

The pentupler multiplies the 784.28 MHz signal by five to generate 3.9214 GHz, the analyzer first IF in low band. A dual cavity bandpass filter centered at 3.9214 GHz eliminates all unwanted multiples of 784.28 MHz.

## **Modulator**

The output of the pentupler is passed through a modulator to adjust the power level into the output mixer. The modulator is controlled by an ALC circuit on the bias board, which is fed by a detector in the output amplifier. If the detected output power is too high, the ALC will drive the modulator to decrease the input level into the output mixer, resulting in a decrease in output power.

## **Coupler**

The first LO signal from the A3A14 first LO distribution amplifier assembly is coupled off, then buffered to drive the output mixer. The main line of the coupler is fed to the LO OUTPUT connector on the rear panel. The loss through the coupler main line is less than 2.5 dB.

## **Output Mixer**

The 3.9214 GHz signal from the modulator is fed into the RF port of the output mixer. The LO port of the output mixer is driven by the buffered first LO signal from the coupler. The output of the mixer is then amplified.

## **Output Amplifier**

The output amplifier filters the signal emerging from the output mixer and then amplifies it into a usable range. The amplifier also contains a detector for leveling the output.

## **Bias Board**

The bias board contains the ALC circuitry for the tracking generator and distributes dc power from the A10 tracking generator control assembly to the rest of the tracking generator. The ALC inputs come from the A10 tracking generator control assembly (for controlling the power level), the EXT ALC INPUT line, and the detector in the output amplifier. The ALC loop drives the modulator.

---

## IF Section

This section applies to all HP 8590 E-Series and L-Series spectrum analyzers, HP 8591C cable TV analyzers, and HP 8594Q QAM analyzers, and describes the operation of the IF section assemblies and the A16 processor/video assembly. The related operation of the A7 analog interface assembly and the A8 Power Supply are also described. Foldout 9-1 illustrates the assembly descriptions in this section.

The A15 motherboard pin designation of related assemblies along the IF signal path are detailed on Foldout 9-1. Refer to Chapter 5 for more information about the connection of analyzer assemblies to the motherboard.

### A11 Bandwidth Filter

The A11 bandwidth filter assembly contains two synchronously tuned LC filter poles and two synchronously tuned crystal filter poles. Buffer amplifiers provide isolation for each filter pole.

Eight IF bandwidths, from 1 kHz to 3 MHz, can be selected in a 1,3,10 sequence. The desired IF passband, or resolution bandwidth, is produced by either a four-pole LC bandpass filter or a four-pole crystal bandpass filter. The A13 bandwidth filter assembly is identical to the A11 assembly and provides two of the four filter poles. The LC bandpass filters provide the 100 kHz to 3 MHz bandwidths, and the crystal bandpass filters provide the 1 kHz to 30 kHz bandwidths.

When a bandwidth is selected, the A7 analog interface assembly interprets the A16 processor/video assembly commands and produces the corresponding bandwidth control currents. The A7 assembly produces a bias voltage (BW5) to select LC or crystal mode, and a bandwidth control current for either the LC filters (BW7) or the crystal filters (BW6).

Bandwidth errors are corrected by the `CAL AMPTD` self-calibration routine. Refer to Chapter 13 for a description of `CAL AMPTD`.

The resolution bandwidths are normally coupled to the frequency span of the analyzer for an optimum ratio of span to resolution bandwidth. Sweep time is also coupled to both resolution bandwidth and span for optimum amplitude response. The resolution bandwidth, sweep time, and span can be set independently.

### A12 Amplitude Control

The A12 amplitude control assembly provides gain or attenuation in eight stages: three step-gain amplifiers and five step attenuators. All stages, except the 10 dB step gain, provide full gain or attenuation when turned on and unity gain when turned off. The 10 dB step gain has a gain of 15 dB when on and a gain of 5 dB when off.

When the reference level is changed, the A7 analog interface assembly interprets the A16 processor/video assembly commands and produces the appropriate combination of gain and attenuation control voltages in 1 dB increments. Reference-level resolution of less than 1 dB is produced by mathematically offsetting the digitized video signal on the A16 processor/video assembly.

A12 step-gain errors are corrected by correction factors produced by the `CAL AMPTD` self-calibration routine. Each correction factor is an offset of the digitized video signal and is stored in nonvolatile memory on the A16 assembly.

A12 step-attenuator errors are corrected by correction constants that are characterized values initially installed at the factory. The corrected calibration attenuators provide the amplitude reference used by `CAL AMPTD` self-calibration routine.

## A13 Bandwidth Filter

The A13 bandwidth filter assembly is identical to the A11 assembly. Refer to the A11 assembly description in this section.

After leaving the A13 assembly, the 21.4 MHz IF signal branches on the A15 motherboard:

- One branch passes directly to the A14 log amplifier assembly.
- A buffer amplifier on the A15 motherboard attenuates the IF signal by 20 dB and distributes it to the card-cage assemblies (AUX\_IF), the rear panel AUX IF OUTPUT connector (AUX\_IF\_BP), and the A25 counterlock assembly (COUNT\_IF). The COUNT\_IF signal is used by the A25 assembly to count the actual IF frequency when **MKR CNT ON** is selected.
- Another buffer amplifier on the A15 assembly sends the IF signal (AUX\_IF) to assemblies installed in the card cage.

## A14 Log Amplifier

The A14 log amplifier assembly provides the following functions:

- **Log Mode.** The input signal is logarithmically displayed due to the sequential response of seven log amplifier stages.
  - The log amplifier stages have an overall range of 70 dB. This allows a greater range of signal amplitudes to be simultaneously displayed.
  - All seven amplifier stages are at maximum gain for low input signal levels.
  - As the signal level increases, the gain of the each 10 dB amplifier is reduced in sequence, with the last stage dropping to unity gain first.
  - The vertical display axis is calibrated in dBm (relative to a milliwatt) rather than volts.
- **Linear Mode.** The seven log amplifier stages are biased to operate as linear amplifiers. Linear gains from 0 dB to 40 dB can be selected.
- **The Video Detector.** The detector is a half-wave rectifier and filter. The video signal (VIDEO\_IF) has a 0 to 2 volt output that is proportional to the signal level.
- **T/C Supply.** A temperature-compensated  $-8$  V reference supply ( $-8$  VT).
  - Maintains amplitude stability of the log stages over temperature.
  - Maintains linear step-gain accuracy by providing a stable voltage source for the linear step-gain control lines that originate on the A7 assembly.



## **A16 Processor/Video and A16A1 Memory Boards**

The A16 assembly coordinates the operation of all analyzer assemblies to perform all analyzer functions. This section briefly describes the major analyzer functions provided directly by the A16 processor/video assembly.

- Selection of the input signal for the ADC. The input MUX selects one of the following:
  - An analog signal from assemblies installed in the card cage.
  - The detected 21.4 MHz IF signal (VIDEO\_IF).
  - A +2 V reference used for ADC calibration of the graticule at top screen.
  - An analog ground (ACOM) reference used for ADC calibration of graticule at bottom screen.
- Final processing of the detected 21.4 MHz IF signal before the video signal is converted by the ADC for further digital processing by the central processing unit (CPU).
  - Video bandwidths from 30 Hz to 3 MHz are available in a 1, 3, 10 sequence.
  - The ADC input MUX selects the positive-peak detector, or bypasses the positive-peak detector, and selects the sample detector. In sample mode, the video signal passes directly to the ADC from the video bandwidth circuitry.
  - The MUX can also select the processed video signal from an assembly in the card cage.
- Mathematical offset of the digitized video signal for greater reference-level resolution and analyzer calibration accuracy.
- Digital control of analyzer assemblies directly over the IO bus.
- Analog control of analyzer assemblies via the A7 analog interface assembly.
- Nonvolatile RAM memory-storage of DLP software, analyzer calibration data, and error correction data. Refer to Chapter 13 for more information about analyzer calibration and error correction.
- Processing and integration of trace and text information for output to the A2 display assembly. The digitized video signal is merged by the CPU with other trace information. The trace information is then combined with text information for input to the display drive circuitry.
- Generation of the A2 display drive signals. The digital display input is converted back into analog voltages by the A16 display drive-circuitry and sent to the A2 assembly. The display signal is also sent to MONITOR OUTPUT on the rear panel.

## A7 Analog Interface

The A7 analog interface assembly converts the digital commands from the A16 assembly to analog control signals for the following assemblies shown on Foldout 9-1:

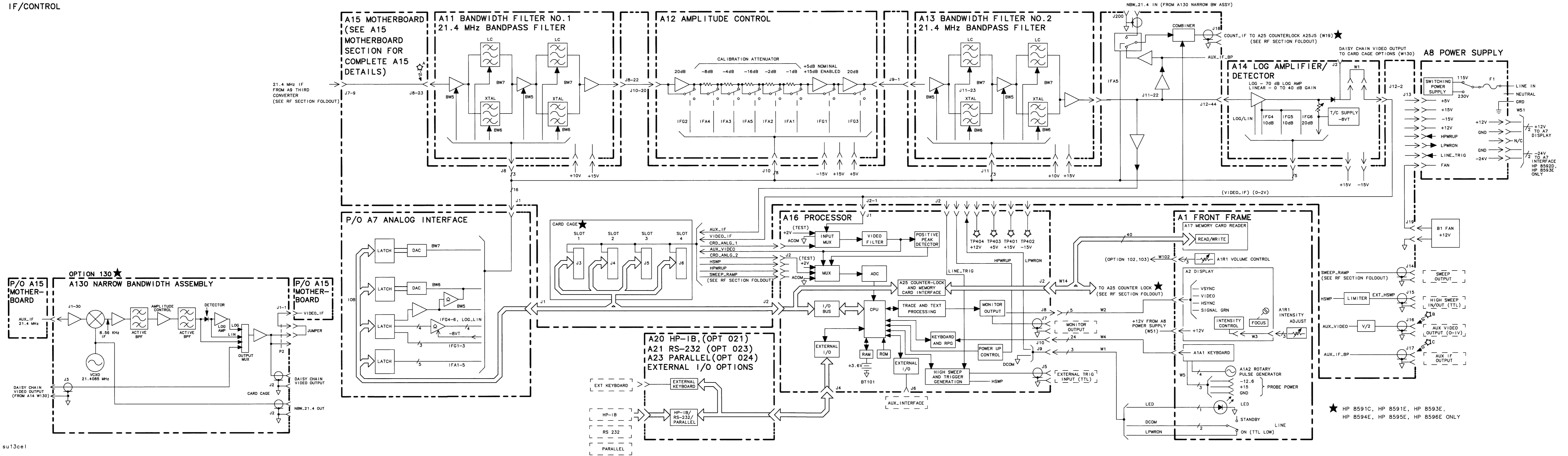
- DAC control of the A11/A13 bandwidth filter assemblies. Refer to “A7 Analog Interface Assembly” for more information about bandwidth switching.
  - LC to crystal mode switching. BW5 controls switching between crystal and LC bandwidth filter modes.
  - Bandwidth control. The A7 bandwidth control DACs supply two control lines to drive the PIN diodes on the A11 and A13 assemblies. Companding DACs are used because their nonlinear output compensates for the nonlinear resistance-versus-current of the PIN diodes they control.
    - BW6 control line. Controls the crystal bandwidths from 30 kHz to 1 kHz. More DAC current produces a narrower bandwidth in crystal mode.
    - BW7 control line. Controls the LC bandwidths from 5 MHz to 100 kHz. In LC mode, more DAC current produces a wider bandwidth.

Bandwidth error is corrected by the **CAL AMPTD** self-calibration routine. Refer to Chapter 13 for a description of **CAL AMPTD**.

- A12 amplitude control assembly. When the reference level is changed, the A7 assembly switches the calibration attenuators and the step gains on the A12 assembly to change the displayed signal position. Refer to “A7 Analog Interface Assembly” in Chapter 7 for more information about switching for the calibration attenuator, the step gains, and the log/linear switch.
  - Calibration attenuators. A TTL high on selected A7 control lines activates a combination of attenuator steps. The 1, 2, 4, and 8 dB step attenuators are combined to provide attenuation in 1 dB increments. Currently, the 16 dB attenuator is not used.
  - 10 dB step gains. Temperature-compensated control voltages activate a combination of the three A12 step-gain stages. Step gains are produced in 10 dB increments over a 50 dB range. Step gain errors are corrected by the **CAL AMPTD** self-calibration routine. Refer to Chapter 13 for a description of **CAL AMPTD**.
- A14 log amplifier assembly. The A7 assembly controls two functions on the A14 assembly:
  - Log/linear mode switching. A temperature-compensated control bias voltage switches the seven A14 amplifier stages to function as either linear amplifiers or logging amplifiers.
  - 10 dB linear step gains. In linear mode, three temperature-compensated control lines bias four of the seven linear amplifiers to provide step gains in 10 dB increments over a 40 dB range. Two amplifiers are switched by one control line to provide the 20 dB step-gain stage.

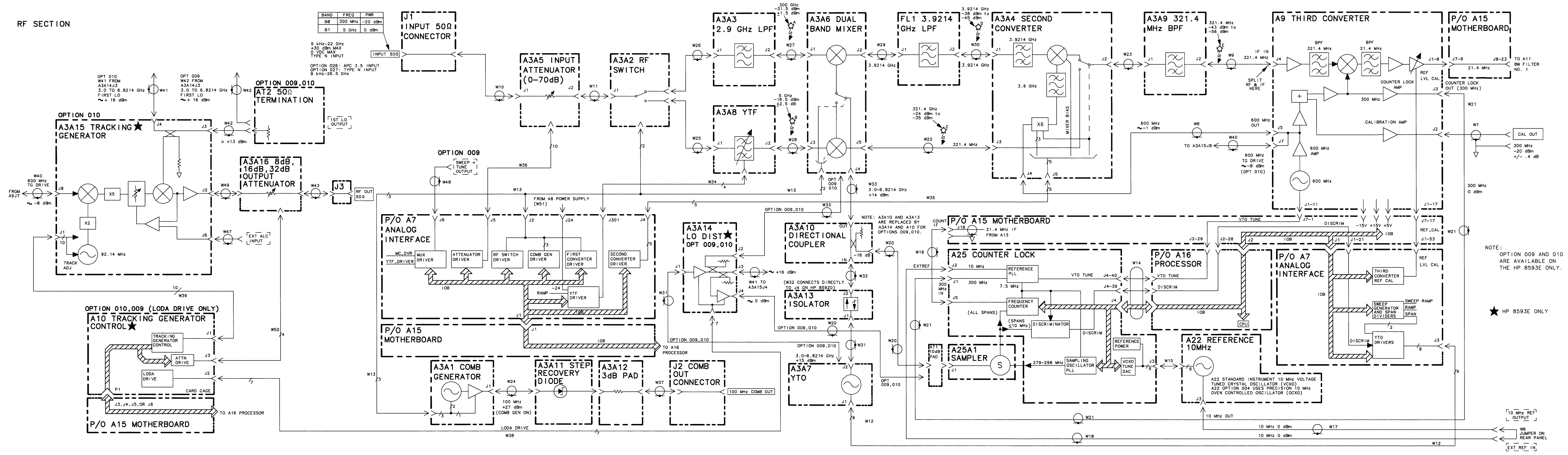
Linear step gain errors are corrected by the **CAL AMPTD** self-calibration routine. Refer to Chapter 13 for a description of **CAL AMPTD**.

IF/CONTROL

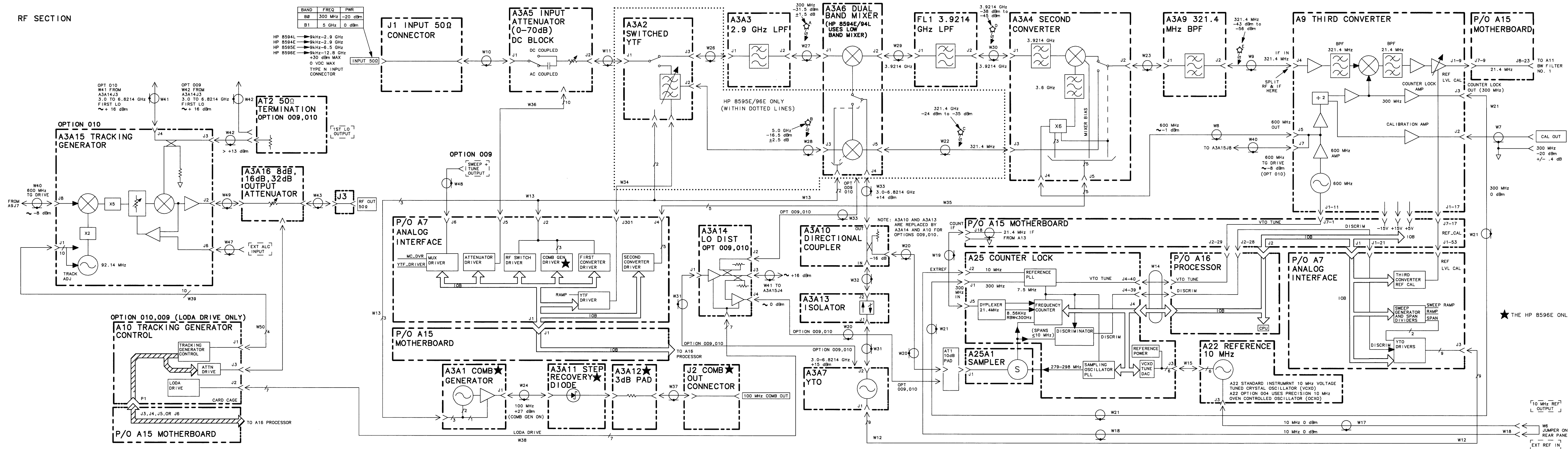




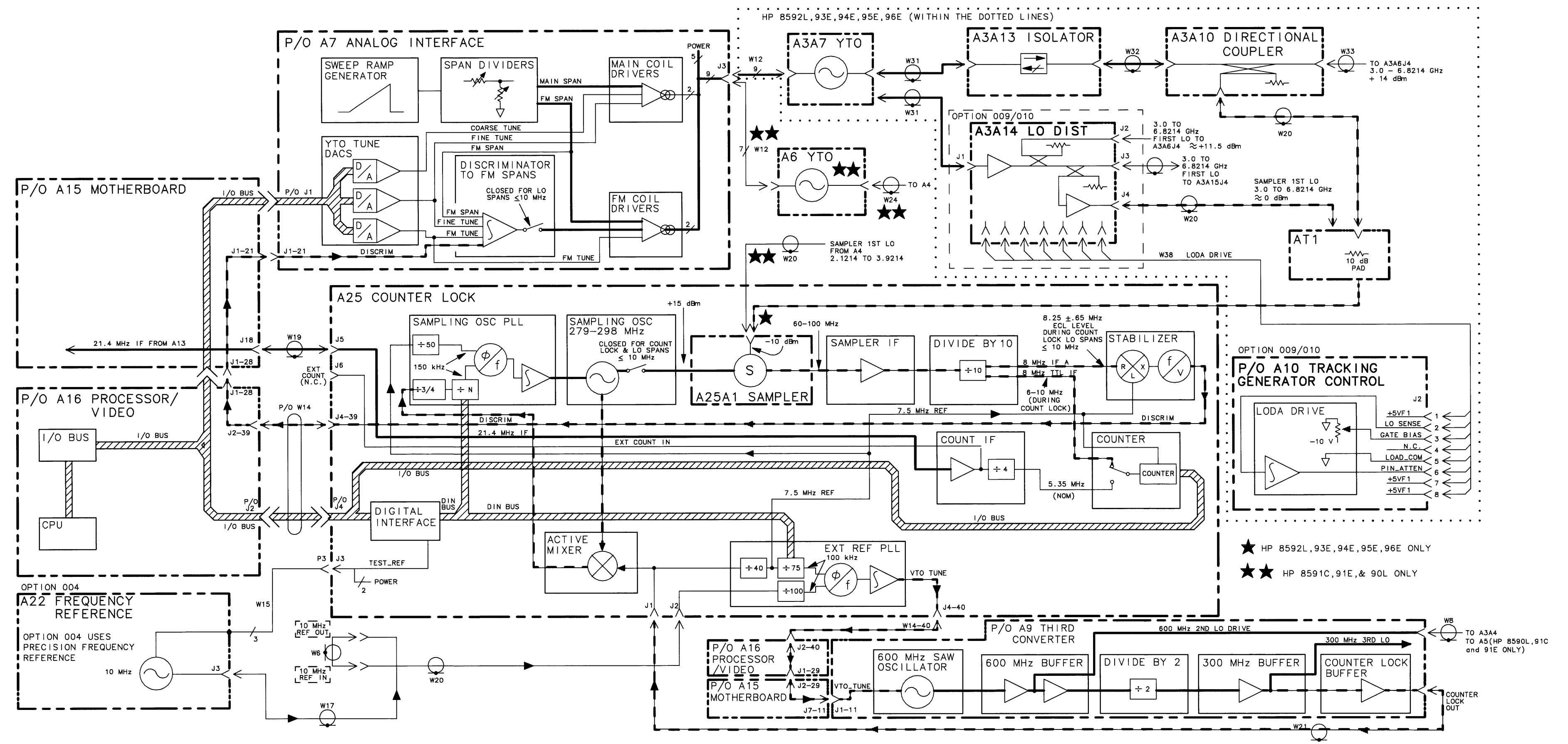
RF SECTION



RF SECTION

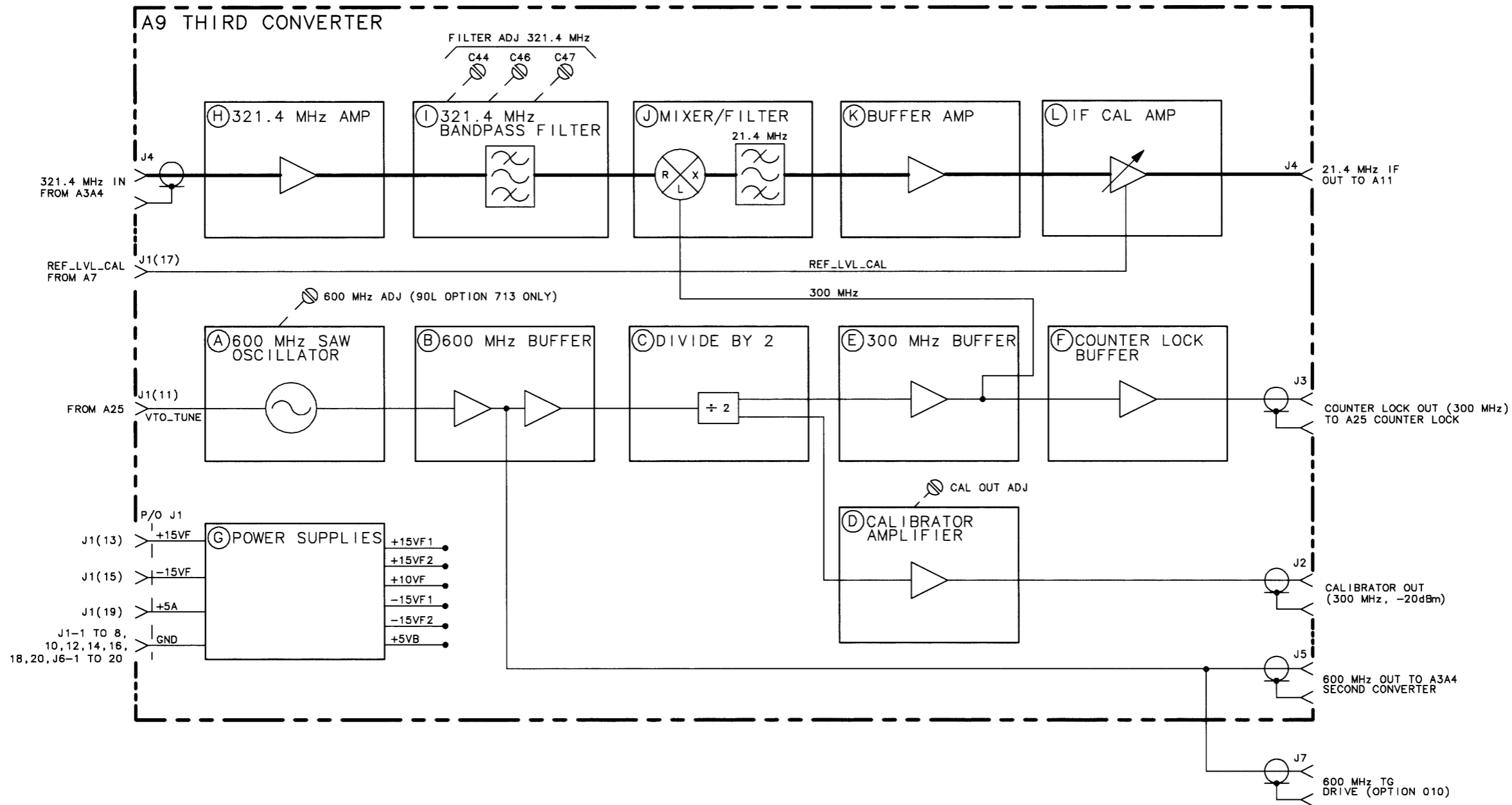


LO SECTION



su17cel

# A9 THIRD CONVERTER ASSEMBLY





## Analyzer Options and Block Diagrams

---

Many options are available to enhance the HP 8590 E-Series and L-Series spectrum analyzers, HP 8591C cable TV analyzers, and HP 8594Q QAM analyzers. Option descriptions are listed numerically in this chapter, and a table provides information on which options are available with your analyzer. Troubleshooting information and block diagrams are also included.

- Option Table

- Option Descriptions

- Troubleshooting

- Tracking Generator, HP 8593E, HP 8594E, HP 8595E, and HP 8596E Option 010
  - First LO Distribution Amplifier (LODA), HP 8593E, HP 8594E, HP 8595E, and HP 8596E Option 009
  - DVB-C, HP 8594Q QAM analyzer Option 190

- Block Diagrams

- Foldout 10-1. HP 8590L, HP 8591C, and 8591E Options 010 and 011 Tracking Generator
  - Foldout 10-2. HP 8593E, 8594E, 8594L, 8595E, 8596E Option 010 Tracking Generator
  - Foldout 10-3. HP 8590 E-Series and HP 8591 C-Series AM/FM Demod TV Trigger
  - Foldout 10-4. HP 8590 E-Series AM/FM Demod Quasi-Peak Detector
  - Foldout 10-5. HP 8594Q Option 190 DVB-C QAM Analyzer Hardware

**Table 10-1. Option Table**

Option		8590L	8591C	8591E	8592L	8593E	8594E 8595E 8596E	8594Q	8594L
001	75 Ohm Input	•		•					
003	Memory Card Reader	•			•				•
004	Precision Freq Reference			•		•	•		
009	LO/Sweep + Tune Out					•	•		
010	Tracking Generator	•		•		•	•		
011	TG/75 Ohm Output	•	•	•					
012	DECT Source					•	•		
015	Soft Tan Carrying Case		•						•
016	Soft Yellow Operating/Carrying Case								•
041	HP-IB and Parallel Interface	•	•	•	•	•	•	•	•
043	RS-232 and Parallel Interface	•		•	•	•	•		•
026	26.5 GHz/APC Conn				•	•			
027	26.5 GHz/N Conn				•	•			
040	Impact Cover	•		•	•	•	•	•	•
042	Soft Carry Case	•	•	•	•	•	•	•	•
050	Improved Amplitude Accy		•	•		•	•		
051	Improved Amplitude Accy		•	•		•	•		
101	Fast ADC			•		•	•		
102	TV SYNC/AM-FM Demod			•		•	•		
103	Quasi-Peak Detector			•		•	•		
105	Gated Video			•		•	•		
107	TV Receiver/Video Tester		•	•		•	•		
110	CT2 Demodulator			•		•	•		
111	Group Delay					•	•		
112	DECT Demodulator					•	•		
119	Noise Figure		•	•		•	•		
130	Narrow Res Bandwidth		•	•		•	•		
140	Narrow BW/Freq Ref			•		•	•		
151	Digital Demod			•		•	•		
161	NADC ROMs			•		•	•		

**Table 10-1. Option Table (continued)**

Option		8590L	8591C	8591E	8592L	8593E	8594E 8595E 8596E	8594Q	8594L
301	Fast ADC/TV SYNC/AM-FM Demod			•		•	•		
E04	DIRTS					•			
H80	PAL Secam Disp	•		•					
H81	NTSC TV Display	•		•					
701	Delete ADC/TV Sync		•						
704	Delete Prec Freq Ref		•					•	
711	50/75 Matching Pad	•		•	•	•	•		•
713	Delete Counter-Lock	•							
908	Rack Mount Without Handles	•	•	•	•	•	•	•	•
909	Rack Mount With Handles	•	•	•	•	•	•	•	•
910	Extra Manual	•	•	•	•	•	•	•	•
915	Service Guides	•	•	•	•	•	•	•	•

### Option Descriptions

#### **75 $\Omega$ Input Impedance (Option 001)**

*For HP 8590L and HP 8591E only.* This option provides a 75 $\Omega$  input impedance instead of the standard 50 $\Omega$  impedance. Analyzers with this option use cables, circuit boards, and front panels that are different from the standard units.

#### **Memory Card Reader (Option 003)**

*For HP 8590L, HP 8592L, and HP 8594L only.* This option provides a memory card reader to save and recall data from a memory card. Analyzers with this option have an opening on the front panel to insert the memory card. Option 003 includes a 32 Kbyte memory card and a memory card holder. The memory card reader is standard for the HP 8591E, HP 8593E, HP 8594E, HP 8595E, and HP 8596E.

Option 003 is also available as a retrofit kit (Option R03) after the purchase of your analyzer, or as a kit HP part number 5062-6456.

#### **Precision Frequency Reference (Option 004)**

*For HP 8591E, HP 8593E, HP 8594E, HP 8595E, and HP 8596E only.* This option provides increased absolute frequency-reference accuracy because the internal oscillators are phase-locked to an internal precision-frequency reference.

Option 004 is also available as a retrofit kit (Option R04) after the purchase of your analyzer, or as a kit HP part number 5062-6459.

#### **LO and Sweep + Tune Outputs on Rear Panel (Option 009)**

*For HP 8593E, HP 8594E, HP 8595E, and HP 8596E only.* Option 009 provides local oscillator output and sweep + tune output at the rear panel for use with external tracking sources such as HP 85644A and HP 85645A.

#### **Tracking Generator (Option 010 and Option 011)**

*For HP 8593E, HP 8594E, HP 8595E, and HP 8596E only.* Option 010 provides a 9 kHz to 2.9 GHz built-in tracking generator. This source-receiver combination makes insertion-loss, frequency response, and return-loss measurements. The tracking generator has a wide distortion-free dynamic range, plus good sensitivity and selectivity. Option 010 has the standard 50 $\Omega$  output impedance.

*HP 8593E, HP 8594E, HP 8595E, and HP 8596E:* Option 010 is also available, with factory installation (Option K10) after the purchase of your analyzer.

*For HP 8590L and HP 8591E only.* Option 010 (100 kHz to 1.8 GHz) or 011 (1 MHz to 1.8 GHz) provides a built-in tracking generator.

Option 010 has the standard 50 $\Omega$  output impedance. Option 011 has 75 $\Omega$  output impedance.

*HP 8590L:* Options 010 and 011 are also available as retrofit kits (Option R10 or R11) after the purchase of your analyzer, or as kits HP part number 5062-6463 and 5062-6479 respectively.

*HP 8591E:* Options 010 and 011 are also available as retrofit kits (Option R10 or R11) after the purchase of your analyzer, or as kits HP part numbers 5062-6460 and 5062-6480 respectively.

### **Protective Tan Operating/Carrying Case with Shoulder Strap (Option 015)**

This option lowers the maximum ambient operating temperature specification by 5 °C. It allows instrument operation while installed in the case.

It is a soft nylon operating and carrying case with a shoulder strap and a pouch for accessories. It includes a CRT viewing hood for operation in direct sunlight. Option 015 can be used to provide additional protection during travel.

### **Protective Yellow Operating/Carrying Case with Shoulder Strap (Option 016)**

This option lowers the maximum ambient operating temperature specification by 5 °C. It allows instrument operation while installed in the case.

It is a soft nylon operating and carrying case with a shoulder strap and a pouch for accessories. It includes a CRT viewing hood for operation in direct sunlight. Option 016 can be used to provide additional protection during travel.

### **HP-IB and Parallel Interface (Option 041)**

Option 041 allows you to control your analyzer from a computer that uses a Hewlett-Packard interface bus (HP-IB). Such computers include the HP 9000 Series 300, and the HP Vectra PC. Option 041 includes a connector for an external keyboard, an HP-IB connector, a parallel interface connector for printers, and the *HP 8590 E-Series and L-Series Spectrum Analyzers, and HP 8591C Cable TV Analyzer Programmer's Guide*.

Option 041 allows the analyzer to copy its screen to a printer or plotter, and includes a separate connector that accepts programming commands from an external keyboard.

Option 041 is also available as a retrofit kit (Option R41) after the purchase of your analyzer, or as a kit HP part number 08590-60380.

---

**Note**            Option 041 can be converted to an Option 043 by ordering the RS-232 and parallel interface connector assembly HP part number 08590- 60369.

---

### **RS-232 and Parallel Interface (Option 043)**

Option 043 allows you to control your analyzer from a computer that uses an RS-232 interface bus. Such computers include the HP Vectra PC, the IBM PC, the AT, and compatibles. It includes a connector for an external keyboard, an RS-232 9-pin connector, a parallel interface connector for printers, and the *HP 8590 E-Series and L-Series Spectrum Analyzers, and HP 8591C Cable TV Analyzer Programmer's Guide*.

Option 043 allows the analyzer to copy its screen to a printer or plotter, and includes a separate connector that accepts programming commands from an external keyboard.

Option 043 is also available as a retrofit kit (Option R43) after the purchase of your analyzer, or as a kit HP part number 08590-60381.

---

**Note**            Option 043 can be converted to an Option 041 by ordering the HP-IB and parallel interface connector assembly HP part number 08590- 60368.

---

## Option Descriptions

### **Frequency Extension to 26.5 GHz with APC-3.5 Connector (Option 026)**

*For HP 8592L and HP 8593E only.* The frequency range of the analyzer is extended from 22 GHz to 26.5 GHz. Analyzers with this option use an APC-3.5 connector on the RF INPUT, and circuit boards and front panels that are different from the standard units.

### **Frequency Extension to 26.5 GHz with N-Type Connector (Option 027)**

*For HP 8592L and HP 8593E only.* The frequency range of the analyzer is extended from 22 GHz to 26.5 GHz. Analyzers with this option use an N-Type connector on the RF INPUT, and circuit boards and front panels that are different from the standard units.

---

**Note**            The extended frequency specifications only apply when using the Type-N to SMA adaptor that is supplied with the option.

---

### **Front Panel Protective Cover (Option 040)**

The impact cover assembly snaps onto the front of your analyzer to protect the front panel during travel and when the unit is not in use.

Option 040 is also available as a kit (Impact Cover Assembly, HP part number 5062-4805).

### **Protective Soft Carrying Case/Back Pack (Option 042)**

A soft carrying case/backpack with a pouch for accessories. Option 042 can be used to provide additional protection during travel. (Cannot operate instrument while installed in case.)

### **Improved Amplitude Accuracy for NADC bands (Option 050)**

*For HP 8591E, HP 8593E, HP 8594E, HP 8595E, and HP 8596E only.* Improved amplitude accuracy for NADC. This is an amplitude calibration that improves specifications to  $\pm 0.7$  dB at 20-30 °C for: NADC frequency bands 824 to 849 MHz and 869 to 894 MHz.

Option 050 is also available as a service center only retrofit kit (Option R50) after the purchase of your analyzer.

### **Improved Amplitude Accuracy for PDC bands (Option 051)**

*For HP 8591E, HP 8593E, HP 8594E, HP 8595E, and HP 8596E only.* Improved amplitude accuracy for the high and low frequency bands of PDC. This is an amplitude calibration that improves specifications to  $\pm 0.5$  dB at 20-30 °C for the PDC frequency bands in the 810 to 956 MHz and 1429 to 1501 MHz frequency ranges.

Option 051 is also available as a service center only retrofit kit (Option R51) after the purchase of your analyzer.

### **Improved Amplitude Accuracy for PHS (Option 052)**

*For HP 8593E, HP 8594E, HP 8595E, and HP 8596E only.* Improved amplitude accuracy for PHS. This is an amplitude calibration that improves specifications to  $\pm 0.5$  dB at 20-30 °C for the PHS frequency band in the 1895 to 1918 MHz frequency range.

Option 052 is also available as a service center only retrofit kit (Option R52) after the purchase of your analyzer.

### **Improved Amplitude Accuracy for CDMA (Option 053)**

*For HP 8591E, HP 8593E, HP 8594E, HP 8595E, and HP 8596E only.* Improved amplitude accuracy for CDMA. This is an amplitude calibration that improves specifications to  $\pm 0.6$  dB at 20-30 °C for CDMA 824 to 849 MHz and 869 to 894 MHz frequency ranges.

Option 053 is also available as a service center only retrofit kit (Option R53) after the purchase of your analyzer.

### **Fast Time Domain Sweeps (Option 101)**

*For HP 8591E, HP 8593E, HP 8594E, HP 8595E, and HP 8596E only.* Option 101 allows sweep times down to 20  $\mu$ s in zero span. In fast sweep times (sweep times less than 20 ms), time domain sweeps are digitized. All trace functions are available for these fast zero-span sweeps. Also see Option 301 below.

Option 101 also adds the analog+ display mode and negative peak detection to the analyzer. The analog+ display mode provides traditional analog display operation combined with the advantages of digital display features like markers, screen titles, and hard copy output. The negative peak detector capability is useful for video modulator balance adjustments and intermodulation distortion measurements.

Option 101 is also available as a retrofit kit (Option R01) after the purchase of your analyzer, or as a kit HP part number 5062-6458.

### **AM/FM Demodulator with Speaker and TV Sync Trigger Circuitry (Option 102)**

*For HP 8591E, HP 8593E, HP 8594E, HP 8595E, and HP 8596E only.* Option 102 enables you to use amplitude or frequency demodulation and to listen to a demodulated signal. Option 102 also allows you to TV trigger on the selected line of a TV video picture frame if both Option 101 and 102 are installed. The sweep triggering works with interlaced or noninterlaced displays for the NTSC, PAL, and SECAM formats. Also see Option 301 below.

Option 102 is also available as a retrofit kit (Option R02) after the purchase of your analyzer, or as a kit HP part number 5062-6457.

### **Quasi-Peak Detector and AM/FM Demodulator With Speaker (Option 103)**

*For HP 8591E, HP 8593E, HP 8594E, HP 8595E, and HP 8596E only.* Option 103 enables you to make automatic or manual quasi-peak measurements, to listen to a demodulated signal, and to use amplitude or frequency demodulation.

Option 103 is available as a kit, order HP 11946A.

## Option Descriptions

### Time-Gated Spectrum Analysis (Option 105)

*For HP 8591E, HP 8593E, HP 8594E, HP 8595E, and HP 8596E only.* Option 105 allows you to selectively measure the spectrum of signals that may overlap in the frequency domain, but be separated in the time domain. By adjusting a time gate based on a user-supplied trigger signal, you can significantly increase the diagnostic capability of your analyzer for time-interleaved signals.

Option 105 is also available as a retrofit kit (Option R15) after the purchase of your analyzer, or as a kit 5062-8218.

Option 101 is recommended in addition to Option 105 since it significantly decreases sweep time and therefore the resolution in the time domain.

### TV Receiver/Video Tester (Option 107)

Option 107 adds non-interfering RF and video measurement capability to the HP 8591C cable TV analyzer.

### CT2 Demodulator (Option 110)

*For HP 8591E, HP 8593E, HP 8594E, HP 8595E, and HP 8596E only.* Option 110 provides built-in demodulation capability for making CT2 transmitter measurements. It must be used with the HP 85717A CT2-CAI measurements personality to make frequency deviation measurements on CT2 cordless telephone handsets and bases.

Option 110 is also available as a retrofit kit (Option R05) after the purchase of your analyzer, or as a kit HP part number 5063-0244.

### Group Delay and Amplitude Flatness (Option 111)

*For HP 8593E, HP 8594E, HP 8595E, and HP 8596E only.* Option 111 allows you to make end-to-end and loop back measurements of group delay and amplitude flatness. It must be used with HP 11770A Link Measurement Personality and the Option 010, Tracking Generator. HP 11768A Group Delay and Amplitude Flatness Retrofit Kit contains both the Option 111 and the HP 11770A Link Measurement Personality. This kit is factory retrofittable only.

### DECT Demodulator (Option 112)

*For HP 8593E, HP 8594E, HP 8595E, and HP 8596E only.* This option provides built-in demodulation capability for making DECT (Digital European Cordless Telephone) measurements. It must be used with HP 85723A measurements personality to make frequency and deviation measurements on DECT handsets and base stations.

Option 112 is also available as a retrofit kit (Option R06) after the purchase of your analyzer.

### Noise Figure (Option 119)

*For HP 8593E, HP 8594E, HP 8595E, and HP 8596E only.* This option along with the HP 85719A Noise-Figure Measurement Personality provide displayed swept noise-figure and gain measurements from 10 MHz to 2.9 GHz.

Option 119 is also available as a retrofit kit (Option R19) after the purchase of your analyzer, or as a kit HP part number 5063-0247.



**Narrow Resolution Bandwidths (Option 130)**

*For HP 8591E, HP 8593E, HP 8594E, HP 8595E, and HP 8596E only.* This option provides additional narrow resolution bandwidths of 30 Hz, 100 Hz, and 300 Hz. These bandwidths improve the analyzer sensitivity and allow you to resolve closely spaced signals.

Option 130 is also available as a retrofit kit (Option R30) after the purchase of your analyzer, or as a kit HP part number 5063-0246.

**Narrow Resolution Bandwidths and Precision Frequency Reference (Option 140)**

*For HP 8591E, HP 8593E, HP 8594E, HP 8595E, and HP 8596E only.* This option is a combination of Option 130 and Option 004. Option 140 provides additional narrow resolution bandwidths of 30 Hz, 100 Hz, and 300 Hz. These bandwidths improve sensitivity and allow you to resolve closely spaced signals. The option also includes an internal precision-frequency reference that improves stability and provides increased absolute frequency accuracy. The precision frequency reference makes the narrow resolution bandwidths more effective and easier to use.

**DSP, Fast ADC and Digital Demodulator (Option 151)**

*For HP 8593E, HP 8594E, HP 8595E, and HP 8596E only.* Option 151 supplies the hardware required for fast time domain sweeps, digital demodulation measurements, and digital signal processor-assisted (DSP) measurements.

Option 151 provides a subset of Option 101 fast time domain functions. Option 101 allows zero span sweep times as low as 20  $\mu\text{s}$  with a step resolution of 20  $\mu\text{s}$  (20  $\mu\text{s}$ , 40  $\mu\text{s}$ , 60  $\mu\text{s}$ , and so forth). Option 151 allows zero span sweep times as low as 40  $\mu\text{s}$  with a sequence of 40  $\mu\text{s}$ , 80  $\mu\text{s}$ , 160  $\mu\text{s}$ , 320  $\mu\text{s}$ , and 160  $\mu\text{s}$  step size thereafter. All trace functions are available for these fast zero-span sweeps.

Since the sweep times offered by Option 151 are a subset of those offered by Option 101, the analog+ display mode is not supported for Option 151.

Option 101 or Option 151 support negative peak detection for an HP 8593E, HP 8594E, HP 8595E, and HP 8596E. The negative peak detector capability is useful for video modulator balance adjustments and intermodulation distortion measurements. Option 101 allows negative peak detection with sweep times as high as 200 ms. Option 151 allows negative peak detection with sweep times as high as 800 ms.

Option 151 requires the installation of Option 160 or 163.

## Option Descriptions

### **PDC/PHS/NADC/CDMA Firmware for Option 151 (Option 160)**

*For HP 8593E, HP 8594E, HP 8595E, and HP 8596E with Option 151 only.* Option 160 provides the digital signal processing (DSP) firmware ROMs necessary to perform PDC, PHS, or NADC digital demodulation-based measurements. It also includes DSP-assisted measurements for CDMA.

Option 160 implements a coherent downconversion, and calculates the minimum RMS error vector magnitude of a timeslot. Carrier frequency error and I-Q origin offset are also extracted from sampled data.

Option 151 with Option 160 and the HP 85718B NADC-TDMA measurements personality provide a complete NADC transmitter RF measurement solution including modulation metrics.

Option 151 with Option 160 and the HP 85720C PDC measurements personality provide a complete PDC transmitter RF measurement solution including modulation metrics.

Option 151 with Option 160 and the HP 85725B CDMA measurements personality provide a CDMA transmitter measurement solution with fast DSP-assisted measurements.

Option 151 with Option 160 and the HP 85726B PHS measurements personality provide a complete PHS transmitter RF measurement solution including modulation metrics.

### **GSM/DCS1800 Firmware for Option 151 (Option 163)**

*For HP 8593E, HP 8594E, HP 8595E, and HP 8596E with Option 151 only.* The option provides Option 151 Digital Demodulator hardware with a firmware algorithm that demodulates GSM and DCS1800 radio carriers in order to make modulation quality measurements.

Option 163 is also available as a retrofit kit (Option R63) for analyzers that already have Option 151 installed. For analyzers that do not have Option 151 installed, a retrofit kit (Option R73) is available to provide both options 151 and 163.

### **TV Picture Display (Option 180)**

*For HP 8591C, HP 8591E, HP 8593E, HP 8594E, HP 8595E, and HP 8596E only.* Option 180 allows you to view an NTSC, PAL, or SECAM television picture on the analyzer display.

Option 180 is also available as a retrofit kit (Option R80) after the purchase of your analyzer, or as a kit HP part number 08591-60089.

### **DVB-C (Option 190)**

*For HP 8594Q only.* Option 190 provides digital video capability to the QAM analyzer for the European Digital Video Broadcast/Cable (DVB-C) standard.

### **TV Sync Trigger Capability/Fast Time-Domain Sweeps and AM/FM Demodulator (Option 301)**

*For HP 8591E, HP 8593E, HP 8594E, HP 8595E, and HP 8596E only.* Option 301 is a combined option made of Options 101 and 102, allowing sweep times down to 20  $\mu$ s in zero span, enabling use of amplitude or frequency demodulation, and allowing a demodulated signal to be listened to. See Options 101 and 102 above for more detailed descriptions.

### **50 $\Omega$ to 75 $\Omega$ Matching Pad (Option 711)**

*For E-Series and L-Series spectrum analyzers.* This option provides a 50 $\Omega$  to 75 $\Omega$  matching pad with dc block to be used on the analyzer input. The pad has a frequency range of 1 MHz to 1.8 GHz. It adapts your standard 50 $\Omega$  analyzer to be compatible with a 75 $\Omega$  system under test.

Option 711 is also available as HP part number 0955-1020.

### **Reduced Frequency Accuracy (Option 713)**

*For HP 8590L only.* Option 713 removes the built-in frequency counter from your analyzer. This reduces the frequency accuracy of your measurements.

### **Rack Mount Kit Without Handles (Option 908)**

This option provides the parts necessary to mount the analyzer in an HP System II cabinet or in a standard 19 inch (482.6 mm) equipment rack.

Option 908 is also available as a kit (HP part number 5062-4841).

### **Rack Mount Kit With Handles (Option 909)**

Option 909 is the same as Option 908 but includes front handles for added convenience.

Option 909 is also available as a kit (HP part number 5062-4840).

### **User's Guide and Calibration Guide (Option 910)**

An additional copy of the *HP 8590 E-Series and L-Series Spectrum Analyzers User's Guide*, the *HP 8590 E-Series and L-Series Spectrum Analyzers Quick Reference Guide*, and the *HP 8590 Series Analyzers Calibration Guide* of the appropriate model number for your analyzer, are available as a set under Option 910.

### **Service Documentation (Option 915)**

Option 915 provides one copy of the assembly-level repair service guide and one copy of the component-level repair service guide. The assembly-level repair service guide describes assembly level troubleshooting procedures and adjustment procedures. The component-level repair service guide includes parts lists, component-location diagrams, and schematic diagrams for selected repairable assemblies. The manuals can be ordered separately.

---

## Troubleshooting Analyzer Options

This section provides information to aid in troubleshooting options installed in the HP 8590 Series analyzers.

---

### Tracking Generator

#### HP 8590L, HP 8591C, and HP 8591E Option 010, 011

Refer to Foldout 10-1, Tracking Generator Block Diagram, for an overview of operation for the tracking generator and its connection to the standard analyzer.

The signals present on the W33 wire harness at A7A1J7 are detailed in Table 10-2 and on Foldout 10-1.

**Table 10-2. Tracking Generator Control Signals at A7A1J7**

A7A1J7 Connector Pin	W33 Wire Color	Mnemonic	Signal Description
1	Brown	MOD_DRIVE	Modulator drive voltage
2		No Connection	
3	Orange	D1	Drain voltage (-.5 to -2.0V)
4	Yellow	G1	Gate 1 bias voltage (5.4 V) (-0.5 to -2.0 V)
5	Green	D2	Drain voltage (-.5 to -2.0V)
6	Blue	G2	Gate 2 bias voltage (5.4 V) (-0.5 to -2.0 V)
7	Violet	ATN_30	Control for 30 dB attenuator step
8	Gray	+15_X3	Switched +15 VF
9	White	ATN_20	Control for 20 dB attenuator step
10	Black	+15VF	+15 VF for Amplifier/Detector
11	White/Brown	ATN_10	Control for 10 dB attenuator step
12	White/Red	+15 VF	+15 VF for Attenuator

## Troubleshooting Analyzer Options

The tracking generator bias voltages from A7A1 tracking generator control board assembly to the A24A2 tracking converter are described in the table below.

**Table 10-3. Tracking Generator Bias Voltages from A7A1 to A24A2**

Source Power (dBm)	Blue <sup>1</sup>	Orange <sup>1</sup>	Green <sup>1</sup>	Yellow <sup>1</sup>	Brown
0	5.33 V	-0.597 V	-0.736 V	5.33 V	-9.75 V
-10	5.33 V	-0.597 V	-0.736 V	5.33 V	-9.75 V
-20	5.33 V	-0.597 V	-0.736 V	5.33 V	-9.72 V
-30	5.33 V	-0.597 V	-0.736 V	5.33 V	-2.88V
-40	5.33 V	-0.597 V	-0.736 V	5.33 V	-0.542 V

<sup>1</sup> These bias voltages should remain constant even when the tracking generator source power changes, as long as the ALC loop is level.

If the A24A3 amplifier/detector is suspect, you can perform some simple checks using a DVM. Measure the +15 V line to ground using an ohmmeter. You should measure approximately 200  $\Omega$ . Check the detector diode using the diode checker on the DVM. Connect the black lead to the center pin of the Video Output and the red lead ground. You should measure approximately 3 k $\Omega$ . Connect the red lead to the center pin of the Video Output and the black lead to ground. you should measure approximately 15 k $\Omega$ . If this measures approximately 8 k $\Omega$ , the detector diode inside is too leaky and will cause a failure.

### Tracking Generator

#### HP 8593E, 8594E, 8595E, 8596E Option 010

The following troubleshooting information is aimed at isolating tracking-generator-related faults to either the A3A15 tracking generator assembly or one of the other supporting assemblies, such as A9, A10, or A3A14. The A3A15 tracking generator assembly is not field-repairable; a rebuilt-exchange assembly is available.

#### If the output goes unlevelled (TG UNLVL message displayed)

A window comparator on the A10 tracking generator control assembly is used to monitor the control line ALC\_MON (ALC Monitor) from the A3A15 assembly. If ALC\_MON is greater than +1.0 Vdc or less than -0.10 Vdc, TG UNLVL will be displayed, indicating that the output of the tracking generator (TG) is unlevelled. The tracking generator can typically be set for +2.75 dBm output power and remain levelled. In any case, the output should remain levelled for output power settings of +1 dBm or less. It is normal for the tracking generator to be unlevelled at frequencies below 300 kHz.

The ALC\_MON line is continuously monitored during a sweep, but the TG UNLVL message will only be displayed at the end of the sweep. For this reason, it is possible that the output could be unlevelled during a portion of a sweep, and although the output returns to a levelled condition by the end of the sweep, TG UNLVL will be displayed at the end of the sweep.

If TG UNLVL is displayed, proceed as follows:

1. Check at which frequencies the output is unlevelled. Set the analyzer to zero span and step the center frequency in 50 MHz increments. Note at which frequencies the output is unlevelled.
2. Check at which power levels the output is unlevelled. Connect the RF OUT 50Ω connector to the INPUT 50Ω connector. With the analyzer in zero span, set CENTER FREQ to 300 MHz or one of the frequencies noted in step 1, with the analyzer in zero span.

Press the following keys.

**AUX CTRL**

**TRACK GEN**

**SRC PWR ON OFF** (ON underlined)

**TRACKING PEAK**

Wait for the PEAKING message to disappear. Step the SRC POWER setting in 1 dB increments and note at which power levels the output is unlevelled. The output should be unlevelled only when the power level is greater than +1 dBm.

## Troubleshooting Analyzer Options

3. Check maximum power available from the tracking generator. Connect the RF OUT 50 $\Omega$  connector to the INPUT 50 $\Omega$  connector. Press the following keys.

PRESET  
AMPLITUDE, 20, +dBm  
LOG dB/DIV, 5, dB  
AUX CTRL  
TRACK GEN  
SRC PWR ON OFF (ON underlined)  
MORE 1 OF 2  
ALC INT EXT (EXT underlined)

The available power should always be greater than +1 dBm. If the output is unlevelled only at specific frequencies, a power hole will usually be visible at those frequencies.

4. Check the LO OUTPUT power level as follows:
  - a. Set the analyzer to zero span at a 0 Hz center frequency.
  - b. Zero and calibrate a power-meter/power-sensor combination. Set the power meter to readout power in dBm. Enter the power sensor's 4 GHz cal factor into the power meter.
  - c. Connect the power sensor to the LO OUTPUT connector on the analyzer rear panel.
  - d. Record the power meter reading. The power level should be greater than +12.5 dBm.
  - e. Increase the analyzer center frequency setting by 100 MHz. The LO OUTPUT frequency will be 3.9214 GHz greater than the center frequency setting.
  - f. Enter the appropriate power sensor cal factor into the power meter.
  - g. Repeat steps d through f until the center frequency setting is 2.9 GHz.
5. If the LO OUTPUT power-level check fails, note the center frequency setting at which the power level was out of tolerance. If the LO OUTPUT power level check passes, proceed to step 7.
6. Place the A3 front end assembly in its service position. Place the A3A15 tracking generator assembly in its service position. Disconnect W41 from A3A15J4 (LO IN). Connect the power sensor to the free end of W41. Repeat the LO OUTPUT power level check above, noting the center frequency settings at which the power level is out of tolerance. The power level for this check should be +16.5 dBm  $\pm$ 2 dB.
  - If the power level is within tolerance at W41, but out of tolerance at the LO OUTPUT (rear panel), and the center frequency setting of the out-of-tolerance power levels is close to the frequencies at which the output is unlevelled, suspect A3A15.
  - If the power level at W41 is also out of tolerance, suspect either the A3A14 LODA assembly, A3A7 YTO assembly, or W41. Refer to the "LO Section" information in Chapter 9.
7. If the output is unlevelled only at certain power level settings or certain frequencies, monitor A10J1 pin 8 with a DVM. Connect the negative DVM lead to A7JTP1. Vary the SRC POWER setting or center frequency setting, as appropriate, and plot the voltage variation versus power level or frequency. A discontinuity in the plot near the frequency or power level at which the output is unlevelled indicates a problem on the A10 tracking generator control assembly.

## Troubleshooting Analyzer Options

### To check excessive residual FM

Either the tracking oscillator or the ALC circuitry could be responsible for excessive residual FM. The residual FM should be measured on another analyzer, such as an HP 8566A/B or HP 8568A/B, using slope detection with the analyzer set to zero span. Proceed as follows to troubleshoot residual FM problems.

1. Perform the Residual FM performance test for the analyzer (see the *HP 8590 E-Series and L-Series Spectrum Analyzers User's Guide*). If this test passes, the 1st LO input and 600 MHz drive signals should be within tolerance. If the test fails, troubleshoot the LO section.
2. Monitor A10J1 pin 5 (TUNE) with an oscilloscope. Connect the oscilloscope probe ground lead to A7TP1. The voltage at this point should be greater than 500 mV.
  - If the voltage is less than 500 mV, perform the “Frequency Tracking Range Check” in the Tracking Oscillator adjustment procedure, in Chapter 2. If this check fails, perform the “Adjustment Procedure” which follows the “Frequency Tracking Range Check”.
  - If the noise on this tune line is greater than 10 mV, troubleshoot the A10 Tracking Generator Control assembly.
3. Monitor the output of the tracking generator with another analyzer (the analyzer should be in zero span). Check for high-amplitude spurious responses from 100 kHz to at least 3 GHz. If the spurious responses are too high in amplitude, the (broadband) ALC detector may cause the ALC loop to oscillate, generating FM sidebands. If any spurious responses are excessively high, refer to “If harmonic/spurious outputs are too high” in this section.
4. If no spurious responses are present, or if the spurious responses are sufficiently low enough in amplitude to not cause a problem, suspect the tracking oscillator in the A3A15 assembly.



### If flatness is out of tolerance

The output level flatness of the tracking generator is specified at a  $-1$  dBm output power setting. In general, most flatness problems will be a result of a failure in the A3A15 Tracking Generator microcircuit. However, the PWR\_LVL signal from the A10 Tracking Generator Control assembly and the 1ST LO IN signal from the A3A14 First LO Distribution Amplifier assembly can also contribute to flatness problems.

1. Check the function of the PWR\_LVL signal from the A10 Tracking Generator Control assembly. Set the SRC POWER setting to a level at which the flatness is out of tolerance. Monitor A10J1 pin 8 with a DVM, step the center frequency setting in 100 MHz increments from 100 MHz to 2.9 GHz, and plot the voltage variation versus frequency. A discontinuity in the plot near the frequency at which the flatness is out of tolerance indicates a problem on the A10 Tracking Generator Control assembly.
2. Check the flatness of the 1ST LO IN signal. Perform the LO OUTPUT amplitude check as described in “If the output goes unlevelled (TG UNLVL message displayed),” in this section.
  - If the check passes, the fault is most likely in the A3A15 Tracking Generator assembly.
  - If the test fails, note the center frequency setting at which the power level was out of tolerance and compare against the frequencies at which the flatness was out of tolerance. Repeat the check with the power sensor connected to the end of W41 that is nearest the A3A15 assembly, noting the center frequency of any out of tolerance power levels. The power level should be  $+16.5$  dBm  $\pm 2$  dB.
    - If the power level is within tolerance at W41, but out of tolerance at the LO OUTPUT connector (rear panel), and the center frequency settings of the out-of-tolerance power levels are close to the frequencies at which the flatness is out of tolerance, suspect the A3A15 assembly.
    - If the power level at W41 is also out of tolerance, suspect either the A3A14 First LO Distribution Amplifier or the A3A7 YTO assembly. Refer to “RF and LO Section for HP 8592L, HP 8593E, HP 8594E, HP 8594L, HP 8594Q, HP 8595E, and HP 8596E Analyzers” in Chapter 9.
3. Check all coax cables, especially semi-rigid cables. A fault in one of these cables can cause a very-high-Q power hole.

## Troubleshooting Analyzer Options

### If vernier accuracy is out of tolerance

Vernier accuracy is a function of the PWR\_LVL drive signal from the A10 tracking generator control assembly and the ALC circuitry on A3A15. The vernier accuracy is specified at 300 MHz. Since vernier accuracy is tested using a broadband power sensor, abnormally high spurious responses could cause the measured vernier accuracy to fail when in fact the accuracy of the 300 MHz signal alone is within specification.

1. Check the PWR\_LVL drive signal from A10. Monitor A10J1 pin 8 with a DVM. Change the SRC POWER setting in 1 dB steps and note the voltage at each power level setting. The voltage should change by the same amount for each 1 dB step. If the voltage does not change by the same amount for each 1 dB step, the fault lies on the A10 Tracking Generator Control assembly.
2. Check for abnormally high spurious outputs. Connect the RF OUT 50 $\Omega$  connector to the input of another analyzer (the test analyzer). Set the test analyzer to sweep from 300 kHz to 2.9 GHz, with a sweeptime of 100 ms or less. Set the HP 8594A to sweep from 300 kHz to 2.9 GHz with a 50 second sweeptime. Press **(SGL SWP)** on the HP 8594A and observe any responses on the test analyzer, ignoring the desired output signal. If any spurious responses are greater than -20 dBc, the vernier accuracy measurement may fail. Refer to "If harmonic/spurious outputs are too high" in this section.
3. Check for excessive LO feedthrough. Use the LO Feedthrough performance test in the *HP 8590 E-Series and L-Series Spectrum Analyzers User's Guide*, but check over a center frequency range of 300 kHz to 100 MHz. The LO Feedthrough will be 3.9214 GHz greater than the center frequency setting.

### If harmonic/spurious outputs are too high

Harmonic and spurious outputs may be generated by A3A15 itself or may be present on either the 600 MHz drive or 1st LO drive signal. There is a direct relationship between spurious signals on the 1st LO and spurious signals on the tracking generator output. There is a five-to-one relationship between spurious signals on the 600 MHz drive and the spurious signals on the tracking generator output. For example, if the 600 MHz signal moves 1 MHz, the tracking generator output signal will move 5 MHz. This is due to the multiplication in the pentupler.

1. If the Harmonic Spurious Responses performance test failed, connect another analyzer, such as an HP 8566A/B, to the HP 8594A LO OUTPUT connector. Set the HP 8594A to each frequency as indicated in the performance test, with the SPAN set to 0 Hz. The 1st LO frequency will be 3.9214 GHz greater than the center frequency setting. Use the HP 8566A/B to measure the level of the second and third harmonics of the 1st LO signal.

---

**Note** The 1st LO typically has a higher harmonic content than the tracking generator output. For the purposes of this check, it is the variation in harmonic content versus frequency which is important.

If the variation of the harmonic level of the 1st LO versus frequency tracks the harmonic level variation of the tracking generator output, repeat step 1 while measuring the 1st LO signal at the end of W41 nearest A3A15. If there is little variation in the 1st LO harmonic level between the LO OUTPUT connector and W41, and the relative variation in harmonic level tracks with the tracking generator output harmonic level, suspect either the A3A14 First LO Distribution Amplifier assembly or the A3A7 YTO assembly.

If the harmonic level variation of the 1st LO versus frequency does not track the harmonic level variation of the tracking generator output, suspect A3A15.

---

2. If sidebands are present at the same frequency offset at every output frequency, use another analyzer to check the spectral purity of the 1st LO and the 600 MHz drive signals. When checking the 1st LO, the HP 8594A must be set to zero span. The 1st LO frequency will be 3.9214 GHz greater than the center frequency setting. A 1 MHz sideband on the 1st LO will appear as a 1 MHz sideband on the output signal.

To verify that the 600 MHz drive or 1st LO signal is responsible for the sidebands, substitute a clean signal for the 600 MHz drive or 1st LO signal. If the sidebands on the output disappear when using the clean signal, the substituted signal was responsible for the sidebands.

---

**Note** The 600 MHz drive signal should be  $-8 \text{ dBm} \pm 3.5 \text{ dB}$ . The 1st LO signal should be  $+16 \text{ dBm} \pm 2 \text{ dB}$ .

---

## Troubleshooting Analyzer Options

### If power sweep is not functioning properly

Power sweep is accomplished by summing an attenuated SWEEP RAMP signal with the PWR\_LVL signal. The SWEEP\_RAMP is attenuated using the 12-bit power sweep DAC. The power sweep DAC output is then fed to a summing amplifier where it is summed with the power level DAC output to yield the PWR\_LVL signal.

1. If some power sweep ranges do not appear to work properly, the fault is probably the power sweep DAC on the A10 Tracking Generator Control assembly. Check the operation of the power sweep DAC as follows:
  - a. Monitor A10U9 pin 7 with an oscilloscope. Connect the ground lead of the oscilloscope to A10TP1. (Refer to the schematic for the A10 Tracking Generator Control assembly.) Trigger the oscilloscope using the analyzer HIGH SWEEP IN/OUT signal on the rear panel.
  - b. Set the analyzer by pressing the following keys.

```
FREQUENCY
CENTER FREQ 300 MHz
SPAN 0 Hz
BW 300 kHz
AUX CTRL
Track Gen
SRC POWER -10 dBm
SRC PWR SWEEP 10 dB
```

- c. The amplitude of the positive-going ramp displayed on the oscilloscope should be approximately 7.8 V.
- d. Change the SRC PWR SWEEP setting to any value between 1 and 11 dB. The ramp amplitude displayed on the oscilloscope should be 780 mV per dB of the SRC PWR SWEEP setting.

---

**Note** Although the source power sweep may be set to a 12.75 dB sweep width, the power sweep function is only warranted to have a 11 dB sweep width.

---

2. Perform the Vernier Accuracy performance test. See the calibration guide for your instrument. If this test fails, refer to “Vernier Accuracy Out of Tolerance” earlier in this section.

### If there is no output power

The A3A15 assembly requires power supplies, a 1st LO signal, and a 600 MHz drive signal in order to provide power output.

1. Check the power supplies on A10J1 and A3A15J1. Refer to the A10 Tracking Generator Control assembly schematic.
2. Verify that the voltage at A10J1 pin 4 is greater than +14 Vdc when the tracking generator is on. If the voltage is not greater than +14 Vdc, troubleshoot A10.
3. Check that ALC\_EXT, measured at A10J1 pin 10, is at a TTL low when the tracking generator is set to ALC INT and at a TTL high when the tracking generator is set to ALC EXT.
4. Check that the 600 MHz drive signal is  $-8 \text{ dBm} \pm 3.5 \text{ dB}$ . If the signal is outside of this range, troubleshoot the A9 Third Converter assembly.
5. Check that the 1st LO input signal is  $+16 \text{ dBm} \pm 2 \text{ dB}$ . Perform the LO OUTPUT amplitude check described in "If the output goes unlevelled (TG UNLVLD message displayed)" earlier in this section, measuring instead at the end of W41 nearest A3A15.
6. Check the tracking adjustment controls. Monitor A10J1 pin 5 with a DVM. On the HP 8594A, use the step keys and knob to change the MAN TRACK ADJUST value from 0 to 4095. The voltage measured should increase from 0 V to +12 V.

---

**Caution**      The following step requires adjustment of A3A15C3. The lifetime of A3A15C3 is rated for less than 10 cycles. Do not adjust A3A15C3 unless it is absolutely necessary.

---

7. If all of the checks above are acceptable, the tracking oscillator might not be functioning. Set up the HP 8594A as indicated in the Tracking Oscillator adjustment procedure in Chapter 2, using an analyzer, such as an HP 8566A/B, in place of the frequency counter. Try to adjust A3A15C3 until a signal is displayed on the HP 8566A/B. If adjusting A3A15C3 does not result in the tracking generator beginning to function, the A3A15 Tracking Generator assembly is suspect.

### First LO Distribution Amplifier (LODA) HP 8593E, 8594E, 8594Q, 8595E, 8596E Option 009

The following troubleshooting information is aimed at isolating 1st LO amplitude-related faults to either the A3A14 LODA assembly, A10 Tracking Generator Control assembly, or the A3A7 YTO assembly. The A3A7 YTO and A3A14 LODA are not field repairable. The A10 Tracking Generator Control assembly is field repairable. However, if the repair time exceeds 30 minutes, it may be more cost-effective to order a replacement assembly rather than to continue component-level repair.

1. Place the A3 Front End assembly in its service position. Place the A10 Tracking Generator Control assembly on an extender board. Remove W33, the semi-rigid coax cable between A3A14 and A3A6. Do not reconnect W20 to AT1.
2. Connect a DVM's negative lead to A10TP2, AGND. Connect the positive lead to A10TP6 (PIN).
3. Set the analyzer by pressing the following keys.

**FREQUENCY**  
**CENTER FREQ** 300 **MHz**  
**SPAN** 20 **MHz**  
**TRIG** **CONT** **SGL** (SGL underlined)

4. Measure the LO power at A3A14J2 and the free end of W20. Refer to Foldout 9-5 for acceptable power level ranges.
5. If both LO power levels are lower than acceptable, the voltage on A10TP6 (PIN) should be above 0 V. If both LO power levels are higher than acceptable, this voltage should be more negative than -10 V.
6. If the voltage measured in step 5 is as described, the LODA drive circuitry is acceptable. Check the A3A7 YTO output power level. Refer to Foldout 12-2 for acceptable power level range.
7. If the voltage measured in step 5 is not as described, either the LODA drive circuitry or the LODA itself is malfunctioning. Check that the operational amplifier's output is consistent with its inputs.
8. Set the analyzer **LINE** switch to off, disconnect W38 from A10J2, then set the analyzer **LINE** switch to on.
9. Connect a jumper between A10J2 and A10TP2. This connects ground A2, a floating ground, to AGND. Connect another jumper between A10TP4, LOS (LO sense) and +10 VR (refer to the A10 schematic).
10. The voltage measured on the DVM should be greater than +14 Vdc.

## Troubleshooting Analyzer Options

11. Move the jumper from +10 VR to -10 VR (refer to the A10 schematic). The voltage measured should be more negative than -13 Vdc.
12. If the voltages do not meet the limits described in steps 10 and 11, troubleshoot the A10 Tracking Generator Control assembly.
13. Connect the positive DVM lead to A10J2 pin 1.
14. The measured voltage should be approximately +5 Vdc. If the voltage is not +5 Vdc, troubleshoot the A10 Tracking Generator Control assembly.
15. Connect the positive DVM lead to A10TP5, GB (gate bias). The voltage should measure within 5% of the GATE voltage listed on the RF section label.
16. If the voltage is not within this range, rotate A10R29 (GATE) through its range while monitoring the DVM.
17. If the voltage varies between 0 Vdc and -2 Vdc, adjust A10R29 (GATE) for a DVM reading within 5% of the GATE voltage listed on the RF section label. If the voltage does not vary outside the range of 0 Vdc and -2 Vdc, troubleshoot the A10 assembly.
18. Set the analyzer **LINE** switch to off, reconnect W38 to A10J2, then set the analyzer **LINE** switch to on.
19. If the DVM reading changes more than 50 mV, the A3A14 LODA is probably defective.

### DVB-C

### HP 8594Q QAM Analyzer Option 190

The following section contains information to assist in troubleshooting the DVB-C mode of operation of the HP 8594Q Option 190 DVB-C QAM analyzer.

---

**Caution** The HP 8594Q Option 190 DVB-C QAM analyzer is a complex instrument to troubleshoot. It is recommended that the following troubleshooting procedures be performed by an HP approved service center only.

---

This information is divided into two sections.

- Troubleshooting Tree
- Option 190 Service Menus

---

### Troubleshooting Tree

The following troubleshooting trees are provided as a tool to use to isolate the most common problems in an HP 8594Q QAM analyzer.

More complex interactive problems will require more detailed troubleshooting knowledge to be gained with experience and help from division engineers.

Use the following guidelines to use the HP 8594Q Option 190 DVB-C QAM analyzer troubleshooting trees use the following guidelines.

1. Start with TREE 1.
2. Read and evaluate each key question in the tree you are working with before moving on to the next tree.
3. Follow through the flow of the trees, sequentially, starting with TREE 1, for every new problem.

There are five troubleshooting trees included in this section.

- Tree 1: Spectrum Analyzer Platform vs Option 190
- Tree 2: Internal Preamplifier
- Tree 3: Option 190
- Tree 4: EVM Problems
- Tree 5: Average Power Test Problems



## Troubleshooting Analyzer Options

<b>TREE 1: Spectrum Analyzer Platform vs Option 190</b> <b>IS THE PROBLEM A SPECTRUM ANALYZER PLATFORM OR OPTION 190 PROBLEM?</b>		
Comments	Problems/Reasons	Diagnostic/Fix Action
<p><i>Isolate the problem.</i></p> <p><i>Note that the base spectrum analyzer platform is the same as an HP 8594E spectrum analyzer.</i></p>	<p>If the failure is in a spectrum analyzer test, it is most likely a problem in the base spectrum analyzer platform.</p>	<p>Check the list of Option 190 failures that can look like spectrum analyzer problems. If none match, follow the typical HP 8594Q analyzer troubleshooting procedure documented in the <i>HP 8590 Series Analyzers Assembly-Level Repair Service Guide</i>.</p>
	<p>If the failure is in an Option 190 specific test under the DVB Analyzer Menu or at HP 859XE Option 190 Recalibration Software, it is most likely to be an Option 190 problem in the card cage.</p>	<p>Check the list of spectrum analyzer platform problems that can look like Option 190 problems. If none match, go to <b>TREE 3</b>.</p>
<p><b>Spectrum Analyzer Platform Problems</b></p> <p><i>Sometimes an Option 190 problem can look like a spectrum analyzer failure.</i></p>	<p>One or more power supply voltages can be shorted to ground.</p>	<p>Detach and remove the Option 190 card cage boards, one at a time, in the following order: DSP, DEMOD, and RF card. After each card is removed, power up the instrument and look for normal spectrum analyzer behavior. The short is probably on the last card you removed.</p>
	<p>High spurious in noise floor, or showing up in spectrum analyzer residual FM test.</p>	<p>The Option 190 cards have many high-speed clock signals, and high amplitude oscillators. Sometimes these signals are coupled into the main spectrum analyzer path, and seen as spurs.</p> <ul style="list-style-type: none"> <li>■ Check the Option 190 80-pin ribbon cable for good seating in its connector.</li> <li>■ Check the Option 190 gray coaxial cables for good seating in its connector.</li> <li>■ Check for proper routing of cables. Refer to the Service Guide.</li> </ul>
	<p>No signal on screen.</p>	<p>The Option 190 RF card has an electronic switch that flips between the input signal to the spectrum analyzer path, or the Option 190 RF card input. This switch may be broken, or frozen so that the input signal never reaches the spectrum analyzer path. Remove the RF card. Reconnect the 321.4 MHz path as in an HP 8594E spectrum analyzer. Check for a trace on screen.</p>
<p><b>Option 190 Problem</b></p> <p><i>Sometimes a spectrum analyzer platform problem can look like an Option 190 problem.</i></p>	<p>Center frequency tuning problem.</p>	<p>If the analyzer tuning/sweep circuits are broken, the Option 190 EVM test will fail.</p> <ol style="list-style-type: none"> <li>1. Check the 10 MHz reference.</li> <li>2. Perform the spectrum analyzer frequency and amplitude calibration. If it fails, follow the typical HP 8594Q troubleshooting procedure documented in the <i>HP 8590 Series Analyzers Assembly-Level Repair Service Guide</i>.</li> </ol>
	<p>Signal level is too high or too low at the 321.4 MHz tap point into the Option 190 cards.</p>	<p>If the QAM analyzer has a problem in the down-conversion chain, the RF board will not receive the correct power level.</p> <p>Probe the input to the RF card. The power level should be between -33 and -25 dBm.</p>

## Troubleshooting Analyzer Options

<b>TREE 2: Internal Preamplifier</b> <b>IS THE PROBLEM IN THE HP 8594Q QAM ANALYZER INTERNAL PREAMPLIFIER?</b>		
Comments	Problems/Reasons	Diagnostic/Fix Action
<b>Internal Preamplifier Problems</b>	No signal on screen	Refer to "5. Set up to use the preamplifier." in the "Making Measurements" chapter of the user's guide for your QAM analyzer. <ol style="list-style-type: none"> <li>1. Go to the Preamplifier Control menu, then select <b>PREAMP ON OFF</b> several times to turn the preamplifier on and off. You should hear a loud click as the coaxial switch puts the preamplifier in and out of the spectrum analyzer path.</li> <li>2. If you do not hear the click, the problem is either in the coaxial switch, or in the control board mounted on top of the IF. Check the wiring harness to and from the control board. Replace the control board, and try to turn the internal preamplifier on and off again.</li> <li>3. Measure the signal at the input to the RF card. If there is no signal, the problem is in the preamplifier, the preamplifier control, or in the analyzer front end.</li> </ol>
	Signal compressed at the top of the display. <i>or</i> Displayed Average Noise Level (DANL) appears to be too high. <i>or</i> Signal level much larger than true power level of the input signal.	Refer to "5. Set up to use the preamplifier." in the "Making Measurements" chapter of the user's guide for your QAM analyzer. <ol style="list-style-type: none"> <li>1. Go to the Preamplifier Setup menu, then select <b>PREAMP GAIN</b>, then enter 0 dB. If the signal jumps 20-26 dB in amplitude, the internal preamplifier is on. Try to turn it off, using <b>PREAMP ON OFF</b> softkey.</li> <li>2. If it does not turn off, the problem is in the coaxial switch, or the preamplifier control board located on top of the IF.</li> </ol>

## Troubleshooting Analyzer Options

TREE 3: Option 190		
HOW DO I CHECK THE BASIC CONFIGURATION?		
Comments	Problems/Reasons	Diagnostic/Fix Action
	The Option 190 consists of three card-cage option cards, DSP firmware, host analyzer firmware, and the DLP. All revisions must be up to date.	<p>Access the option listing under <b>Show Options</b>. Confirm that the option software revisions are current, and that no configuration error message shows. The following is a list of the initial revisions.</p> <ul style="list-style-type: none"> <li>■ Firmware: 961216</li> <li>■ DLP: 961218</li> <li>■ Option 190 DSP: 961206</li> </ul> <p>If you get a configuration error, refer to the "Error Messages" section of the <i>HP 8594Q Option 190 DVB-C QAM Analyzer User's Guide</i>.</p>
WHICH OPTION 190 TEST FAILED?		
Comments	Problems/Reasons	Diagnostic/Fix Action
	The Option 190 Recalibration routine or DVB Demod Test exercises both the Option 190 hardware, and the base spectrum analyzer platform hardware in different tests.	<p>If the Option 190 Recalibration routine or DVB Demod Test fails the EVM test limit, the problem is most likely in the Option 190 hardware/software or the DLP. <b>Go to TREE 4.</b></p> <p>If the Option 190 Recalibration routine or DVB Demod Test fails the average power limit, the problem is most likely in the basic spectrum analyzer platform hardware, the preamplifier, or the DLP. <b>Go to TREE 5.</b></p>
IS THE ANALYZER RECEIVING A GOOD INPUT SIGNAL?		
Comments	Problems/Reasons	Diagnostic/Fix Action
	The test signal comes from the HP 8770 arbitrary waveform synthesizer. It is very sensitive to improperly connected or terminated cables.	View the spectrum on a spectrum analyzer screen. It is centered at 27.6 MHz. Refer to the "Average Channel Measurement" located in the "Making Measurements" chapter of the <i>HP 8594Q Option 190 DVB-C QAM Analyzer User's Guide</i> , for an example of the correct signal shape. The bandwidth depends on the exact test being performed, but the signal will be of the same shape as the example.

## Troubleshooting Analyzer Options

TREE 4: EVM Problems		
IS THE FAILURE IN A SINGLE CHANNEL BANDWIDTH?		
Comments	Problems/Reasons	Diagnostic/Fix Action
	If the problem is concentrated in a single-channel bandwidth setting, the problem is probably in the RF option board.	Replace the suspected RF board assembly with a "known" good RF board. If the analyzer passes the EVM test, save the bad board and the matching test data for division analysis.
IS THE FAILURE IN A SINGLE SYMBOL RATE?		
Comments	Problems/Reasons	Diagnostic/Fix Action
	If the problem is concentrated in a single-channel bandwidth setting, the problem is likely in the DEMOD board assembly.	Replace the suspect DEMOD board assembly with a "known" good DEMOD board. If the analyzer passes the EVM test, save the bad board and the matching test data for division analysis.
IS THE FAILURE WITH THE PREAMPLIFIER "ON" ONLY?		
Comments	Problems/Reasons	Diagnostic/Fix Action
	The test conditions with the preamplifier "ON" are designed to test the functionality of the preamplifier <i>and</i> to stress the analyzer sensitivity to low signals. If the problem could be in the preamplifier, the extra noise in the RF option board path, or it could be in the spectrum analyzer platform DANL.	<ul style="list-style-type: none"> <li>■ Evaluate the preamplifier. Refer to "5. Set up to use the preamplifier." in the "Making Measurements" chapter of the user's guide for your QAM analyzer.               <ol style="list-style-type: none"> <li>1. Remove the HP 8770 test signal, then apply the CAL signal to the RF input.</li> <li>2. Do the "Measuring the Preamplifier Gain" procedure to find out what suspect preamplifier gain truly is. It should be <math>23 \pm 3</math> dB. If it is not, the problem is in the preamplifier.</li> <li>3. Test the preamplifier control by turning the preamplifier on and off, using <b>PREAMP ON OFF</b>.</li> </ol> </li> <li>■ Evaluate the spectrum analyzer platform DANL. If the DANL is out of specification, the problem is in the spectrum analyzer down-conversion path.</li> <li>■ Swap the RF option card with a "known" good card. Rerun the test. If the problem is resolved, save the bad board and the matching test data for</li> </ul>

## Troubleshooting Analyzer Options

<b>TREE 4: EVM Problems (continued)</b> <b>DO THE FAILURES APPEAR IN MULTIPLE PLACES?</b>		
Comments	Problems/Reasons	Diagnostic/Fix Action
<p><b>Connector Problems</b></p> <p><i>Care must be taken on inserting the cables into the board to keep the male connectors well aligned with the female connectors. Inspect the cable male connector before EVERY insertion. Correct any tilt or off-center of the center pin, if necessary.</i></p>	<p>The MCX connectors used on the gray cables on the option cards are delicate.</p>	<p>Inspect both the female connector on the board, and the male connector on the cable.</p> <p>If the female connector on the board is not severely crushed, it can often be cleared using a dental pick. If the male connector pin appears to be off center, recenter using fine tweezers.</p> <p>Replace the board only if the connector center hole is crushed beyond repair.</p>
<p><i>Failures can appear in multiple places in the EVM test across multiple-channel bandwidths and symbol rates, regardless of the preamplifier settings.</i></p>	<p>The problem is in the main demodulation path used by all EVM test modes.</p>	<ol style="list-style-type: none"> <li>1. Check the adjustment of the 71.025 MHz oscillator on the RF option board. The nominal setting at room temperature after warmup and instrument preset (PRESET) of the instrument should be 71.025 MHz.                             <p style="margin-left: 20px;">If it has drifted off frequency, use a tweaker to adjust C402 to bring the frequency to 71.025 MHz. Watch the signal. Is it stable, or does it drift again?</p> <p style="margin-left: 20px;">If it drifts again, Q400 is probably bad. Q400 is a specially selected 2N3904 transistor. Check with the division to obtain an approved replacement.</p> <p style="margin-left: 20px;">Rerun the EVM test to check if the problem is resolved. If not, proceed to step 2.</p> </li> <li>2. Replace the RF board with a "known" good board. Does the instrument now pass the EVM test?                             <p style="margin-left: 20px;">If so, save the bad board and the matching test data for division analysis.</p> <p style="margin-left: 20px;">If not, continue to step 3.</p> </li> <li>3. Replace the DEMOD option board with a "known" good board. Does the instrument now pass the EVM test?                             <p style="margin-left: 20px;">If so, save the bad board and the matching test data for division analysis.</p> <p style="margin-left: 20px;">If not, continue to step 4.</p> </li> <li>4. Replace the DSP option board with a "known" good board. Does the instrument now pass the EVM test?                             <p style="margin-left: 20px;">If so, save the bad board and the matching test data for division analysis.</p> <p style="margin-left: 20px;">If not, after swapping to a full set of "known" good boards, set the instrument aside for further analysis.</p> </li> </ol>

## Troubleshooting Analyzer Options

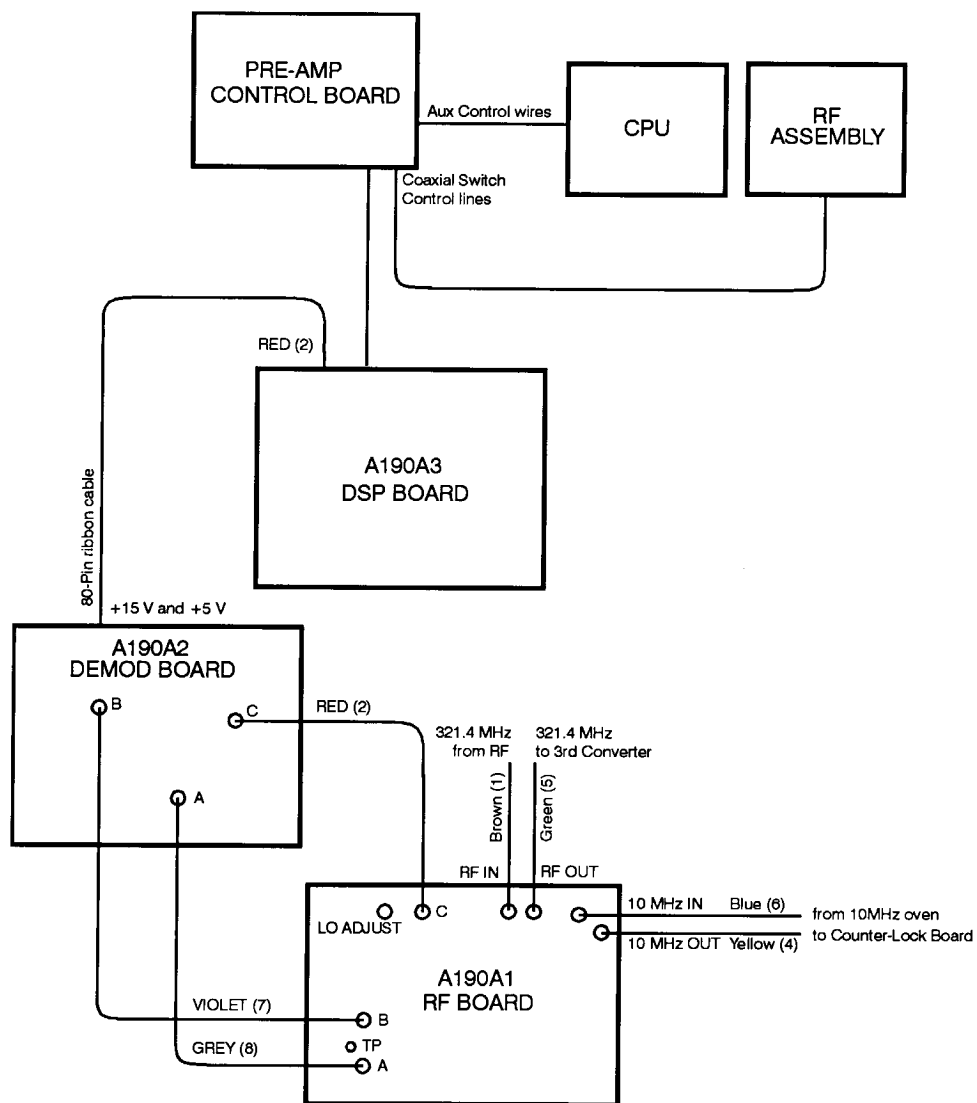
<b>TREE 5: Average Power Test Problems</b> <b>IS THE TEST SIGNAL AT THE PROPER LEVEL?</b>		
Comments	Problems/Reasons	Diagnostic/Fix Action
<b>Test Signal Level</b>	The test signal comes from the HP 8770 arbitrary waveform synthesizer.	<p>View the spectrum on a spectrum analyzer screen. It is centered at 27.6 MHz. Refer to the "Average Channel Measurement" located in the "Making Measurements" chapter of the <i>HP 8594Q Option 190 DVB-C QAM Analyzer User's Guide</i> for an example of the correct signal shape. The bandwidth depends on the exact test being performed, but the signal will be of the same shape as the example.</p> <p>If the signal appears to be normal, check the output power through a power meter. Is the test signal at the right power level? It should be approximately <i>4 dBm - 0 (HP 8770A attenuator setting) - pad with the preamplifier OFF</i>, and <i>4 dBm - 50 (HP 8770A attenuator setting) - pad</i> when the preamplifier is on.</p>
<b>Preamplifier OFF</b>	If the problem appears with the preamplifier OFF ( <u>PREAMP ON OFF</u> , OFF is underlined), the root cause is likely to be a spectrum analyzer platform path problem or DSP problem. The DLP uses only the HP 8594E spectrum analyzer hardware and the DSP card to execute the average power measurement.	<p>Replace the DSP option board with a "known" good board. Rerun the test to see if it passes.</p> <p>If so, save the bad board and the matching test data for division analysis.</p> <p>If not, after swapping the DSP does not work, perform an analyzer self calibration. Troubleshoot as a spectrum analyzer platform problem if it does not pass.</p>

**TREE 5: Average Power Test Problems (continued)**

**IS THE TEST SIGNAL AT THE PROPER LEVEL?**

Comments	Problems/Reasons	Diagnostic/Fix Action
<p><b>Preamplifier ON</b></p>	<p>If the problem appears with the preamplifier ON (<u>PREAMP ON OFF</u>, ON is underlined) the root cause is likely to be the preamplifier or the preamplifier control.</p>	<ol style="list-style-type: none"> <li>1. Evaluate the preamplifier. Refer to "5. Set up to use the preamplifier." in the "Making Measurements" chapter of the user's guide for your QAM analyzer.               <ol style="list-style-type: none"> <li>a. Remove the HP 8770 test signal, then apply the CAL signal to the RF input.</li> <li>b. Do the "Measuring the Preamplifier Gain" procedure to find out what suspect preamplifier gain truly is. It should be <math>23 \pm 3</math> dB. If it is not, the problem is in the preamplifier.</li> <li>c. Test the preamplifier control by turning the preamplifier on and off, using <u>PREAMP ON OFF</u>.</li> </ol> </li> <li>2. If you cannot control the preamplifier, the problem is in the preamplifier control board. Swap the preamplifier control board with a "known" good board.</li> <li>3. If the problem persists, replace the DSP with a "known" good board. Rerun the test to see if it passes. If so, save the bad board and the matching test data for division analysis.</li> <li>4. If swapping the DSP does not work, perform an analyzer self calibration. Troubleshoot as a spectrum analyzer platform problem if it does not pass.</li> </ol>

# Option 190 DVB-C Connection Diagram



ss12q



---

## Option 190 DVB-C Service Menus

Service menus are available in the HP 8594Q Option 190 DVB-C QAM analyzer and are intended to assist in troubleshooting problems specific to the Option 190. These service menus can *only* be enabled using a passcode.

Enabling the service menus allows you to do the following:

1. Enable diagnostics information during demodulation measurements that shows important level and state variables accompanying the normal measurement results.
2. Enable diagnostics and/or optional keys and menus elsewhere in the measurement menus.
3. Control various parameters that the typical user would never need.
4. Entry into a menu of keys useful for troubleshooting the Option 190 downconverter.

---

**Caution** It is important to realize that all the keys, with one exception (RCVR CAL ON OFF,) under Service Menus intentionally retain their values through presets and power cycles like all other Setup keys. This is done so board swapping may be done during troubleshooting and the previous state can be retained. After troubleshooting is completed, the DEFAULT SETUP key should be press to clear any conditions set via the Service Menus.

---

### Passcode

To enable the Service Menus you must enter a passcode. Perform the following procedure to access the Service Menus.

1. Press the following keys.

```

PRESET
DVB-C ANALYZER
Setup
Analyzer Setup
MAX MIXER LEVEL
- 1 2 3 dBm

```

## Option 190 DVB-C Service Menus

### Menu 1 of 3

**DIAGS ON OFF** enables the display of the diagnostics data on demod-based measurements along with the measurement results. This data is shown as a small highlighted block on the screen. The exact meaning of each of the data items is detailed in the “Diagnostic Data” section.

**IGNORE ON OFF** enables a mode in which demod-based measurements will ignore any QAM acquisition or measurement failure and show the measurement anyway. This is useful to observe the constellation under this condition since it can yield valuable clues about the particular fault (spinning or random constellation). Note that this only ignores acquisition or measurement unlocks; it will not ignore a 240 MHz PLL unlock or level set failure.

**KEYS ON OFF** enables the following diagnostic and optional control keys located elsewhere in the menus.

- **Service** is located in the **lq Constln** menu.
- **AGC HOLD RUN** and **DNCVRTR ATTEN** are shown during a continuous (live) demod-based measurement. **DNCVRTR ATTEN** is used to manually enter a value of Option 190 downconverter attenuation independent of the value set by the level-set algorithm, and display in the diagnostic data. Useful information can be gleaned by entering values different than that set by the level-setting algorithm, then observing the effects on the constellation, or other measurement.

Note that values are entered “blind” into the keypad, terminated by **dB**; there is no visible active function area on the screen. Note also that the diagnostic data does not change to reflect the new value of downconverter attenuation. Also, only even values of attenuation are utilized, due to only 2 dB steps are available on the board. **AGC HOLD RUN** (hold underlined) will freeze the AGC loop on the Option 190 demodulator input. This allows subtle effects to be observed without being obscured by the action of the AGC loop.

- **VARIANCE SD 90%** is located in the **Modulation Accuracy** menu. When set to **SD** (**SD** is underlined), this will make averaged measurements display the standard deviation instead of the 90% confidence value of measurement variance.
- **METRIC ON OFF** located in the **SER, C/N Margin** menu, when set to **ON** (**on** is underlined) will make the **SER** measurement display the **EVM**, or **MER**, that accompanies the measurement in a manner identical to the channel response measurements.

**Dncvtr Test** leads to a set of menus that allows the setup of various Option 190 downconverter functions in a manner convenient to troubleshooting, for example, no measurements are run. The softkeys located under **Dncvtr Test** are documented in the “Downconverter Test” section.

**Menu 2 of 3**

**RCVR CAL ON OFF** allows you to enable or disable use of the Option 190 calibration by demod-based measurements. The Option 190 calibration is a special factory calibration that allows us to compensate for the linear distortion of the analyzer. This improves the channel response measurement results as well as increases the ability of the demodulator to lock to a signal. The calibration “values” are kept in the analyzer CMOS RAM memory and automatically uploaded by the analyzer firmware to the Option 190 board set at power-up. If the cal is missing or corrupt, **RCVR CAL ON OFF** will remain in the OFF position (OFF is underlined) and cannot be toggled ON. This key is the one exception to the Setup keys: it does NOT retain its value through preset or power cycles. The reason being the mode entry routine will automatically turn **RCVR CAL ON OFF** to OFF (OFF is underlined) if it detects that the Option 190 cal is missing or corrupted (and display a message). The mode entry routine will also turn **RCVR CAL ON OFF** to ON (ON is underlined) if the CAL is OK. Pressing **DEFAULT SETUP** key will set **RCVR CAL ON OFF** to ON (if there is a valid CAL). The state of **RCVRCAL ON OFF** is also shown in the “Diagnostic Data” section.

**Dsp Evm Corr** key leads to a menu which allows you to individually enable or disable DSP based evm correction for each of the 3 bandwidths, 2,4 or 8 MHz. For example, the “8 MHz CH ON OFF” key when set to ON enables DSP based corrections on 8 MHz channels. As described in Modulation Accuracy (metrics) above, the 2 & 4 MHz bandwidths normally have this enabled, but not the 8 MHz bandwidth.

**EVM CORR ON OFF** enables DLP based evm corrections on channels that do not have DSP based evm corrections enabled. The diagnostics data (see the “Diagnostic Data” section) displays if DSP or DLP based evm corrections are on for the current analyzer state.

**CNTL A 1 0** allows you to toggle the preamp bypass switch independently of **PREAMP ON OFF** key. Selecting 1 puts the switch in preamp mode, 0 puts the switch in bypass mode. This is useful for troubleshooting the preamp drive circuits.

**SHOW REVDATES** key displays all three software revision dates: the HP 8594Q QAM analyzer firmware (“F/W:”), Option 190 DSP firmware (“DSP:”) and DLP.

## Option 190 DVB-C Service Menus

### Menu 3 of 3:

**COUPLING ON OFF** (when set to OFF) allows you to disable the automatic selection of channel bandwidth when a new channel is entered. This may be used if you want to ignore the FTZ 'D' channel layout while using 'D' channels.

**RETUNE ON OFF** (when set to OFF) allows you to disable the automatic re-setting of the 71.1 MHz oscillator that is done when a demod-based measurement signal acquisition fails. This can be set to off to investigate signal acquisition for a fixed 71.1 MHz tuning state (lower, centered or upper).

**ACQ MER LIMIT** allows entry of values from 0 to 50 dB (the default is 20 dB). This value is used during a demod-based measurement signal-acquisition routine. If the measured value of MER is less than this limit and the **MER LMT ON OFF** key in the **Demod Setup** menu is ON, the acquisition routine will abort with a MER TOO LOW message.

**MEAS MER LIMIT** allows entry of values from 0 to 50 dB (the default is 20 dB). This value is used during a demod-based measurement. If the measured value of MER is less than this limit and the **MER LMT ON OFF** key in the **Demod Setup** menu is ON, the measurement will abort with a MER TOO LOW message.

---

**Note**            Setting **MER LMT ON OFF** in the Demod Setup menu to OFF will ignore both "ACQ" and "MEAS" MER limits. This is essentially a shortcut to setting both ACQ and MEAS MER limits to 0 dB to allow acquisition and measurement of very noisy signals.

---

**IGNOR BW ON OFF** is used to disable the automatic channel bandwidth verification that is done at the start of single signal demod based measurements. If this key is set to ON, the signal's (approximate) measured occupied bandwidth is not compared against the setting of the **CHAN BW SELECT** key.

## Diagnostic Data

When **DIAGS ON OFF** in the **Service Menus** is set to ON, demod-based measurements will include the display of extra diagnostic data in a small highlighted block on the screen.

The format is: **XX dB YY,Z ABCD** where:

**XX** is the amount of dB set on the Option 190 downconverter assembly after the automatic level setting algorithm has run. This will be an even number from 0 to 60 dB.

**YY** is the final AGC (signal) reading from the Option 190 demodulator input stage in hexadecimal after the automatic level setting algorithm has run. This will be 80 (128 decimal) or slightly more than this. The target for the algorithm is 80 to 82.

**Z** is a number that indicates the sequence of action taken by the algorithm. There are 6 possible values:

**0:** the initial AGC reading indicated no adjustment in was needed. This should rarely happen since we intentionally set the gain equation for the initial amount of attenuation to always make it excessive to guarantee under-drive at the demodulator input.

**1:** The initial AGC reading indicated excess attenuation of less than 12 dB. The attenuation was reduced by this amount and a subsequent AGC reading indicated the signal was within the target. This is the most common case.

**2:** The initial AGC reading indicated excess attenuation of less than 12 dB. The attenuation was reduced by this amount and a subsequent AGC reading indicated adjustment was still required (but less than 12 dB). The attenuation was reduced again by the required amount and a final AGC reading was taken. This is the next most common case.

**3:** The initial AGC reading indicated excess attenuation of 12 dB (or more). The attenuation was reduced by 12 dB and a subsequent AGC reading indicated the signal was within target. This will rarely happen.

**4:** The initial AGC reading indicated excess attenuation of 12 dB (or more). the attenuation was reduced by 12 dB and a subsequent AGC reading indicated adjustment was still required (but less than 12dB). The attenuation was reduced again by the required amount and a final AGC reading was taken. This is rare, but possible (if the downconverter has more loss than “usual”). Note that this case doesn’t check the final reading and reduce the attenuation a third time if the target is not reached. So the level may not be optimum.

**5:** The second AGC reading in case 2 or 4 above indicated adjustment was required and the amount of excess attenuation was 12 dB or more (for example, the cumulative amount of attenuation decrease would be 24 dB or more). This can happen if the signal path has excess loss. This case generates the **Downconverter Level Set Failed** error message.

**A** is a number which represents the current Option 190 71.1 MHz oscillator “state”:

**1:** lower

**2:** centered

**3:** upper

**B** is the character **R** if “RCVR CAL” is ON, **r** if it is OFF.

**C** is the character **D** if DSP based evm corrections are ON, **d** if they are not.

**D** is the character **E** if DLP based evm corrections are ON, **e** if they are not.

A typical readout of a -20 dBm, 8 MHz channel might be: **46 dB 80,2 2RdE**

## Option 190 DVB-C Service Menus

### Downconverter Test

**Dncvrtr Test** in the **Service Menus** leads to a set of menus used to troubleshoot Option 190 RF Downconverter boards. Note that pressing it also sets up the analyzer for 0 span and routes the signal path to Option 190 board set instead of the spectrum analyzer. Thus, if a signal was present on the analyzer input, the screen will show only the analyzer noise floor after pressing **Dncvrtr Test**.

The **Switch Control** key leads to a menu which will allow you to select one of the 5 possible paths:

1. **Spectrum Analyzer** will route the signal back to the spectrum analyzer. If you press this, the screen will show the signal (in 0 span) if one is present on the analyzer input.
2. **Demod 8 Mz SAW** will route the signal through the Option 190 demod, 8 MHz SAW filter path.
3. **Demod 4 Mz SAW** will route the signal through the Option 190 demod, 4 MHz SAW filter path.
4. **Demod 2 Mz SAW** will route the signal through the Option 190 demod, 2 MHz SAW filter path.
5. **Demod Bypass** will route the signal through the Option 190 demod, bypass (no SAW filter) path.

**DNCVRTR ATTEN** allows entries from 0 to 60 dB to set the amount of attenuation. Note that only even integer values are actually utilized and the value is set to 30 dB when entering the downconverter test menu.

**PLL Control** leads to a menu which will allow you to select the 240 MHz PLL oscillator frequency (based on the channel bandwidth):

1. **PLL 8 Mz Channel** will set it to 243.4 MHz.
2. **PLL 4 Mz Channel** will set it to 246.85 MHz.
3. **PLL 2 Mz Channel** will set it to 248.571 MHz.

**Custom Freq** in the **PLL Control** menu leads to another menu which will allow you to set the 240 MHz oscillator to a custom frequency by specifying the 'N' and 'R' words which are sent as 19 individual (serial, MSB 1st) bits to the National semi LMX2325 PLL chip. The highest 11 bits of the 'N' word is used to load the 'B' register, the next 7 bits are used to load the 'A' register, the lowest order bit always a 0 for 'N' words. The highest 3 bits of the 'R' word are not used, the next bit is a 1 to specify the 32/33 prescalar, the next 14 bits are used to load the 'R' register, the lowest order bit always a 1 for 'R' words. The frequency is given by:

$$F_b = 10 \text{ MHz} * N/R \text{ where } N = (32*B)+A$$

## Option 190 DVB-C Service Menus

For the 8 MHz channels,  $R=50$ ,  $B=38$  and  $A=1$  which yields 243.4 MHz. For the 4 MHz channels,  $R=35$ ,  $B=27$  and  $A=0$  which yields 246.85 MHz. For the 2 MHz channels,  $R=49$ ,  $B=38$  and  $A=2$  which yields 246.571 MHz. The two separate keys, `DECIMAL PLL N` and `DECIMAL PLL R`, are used to enter the 2 values and contain the default values for the 8 MHz channel: 9720 (2602 hex) for the N word and 32869 (8065 hex) for the R word.

`SHOW AGC VALUES` will take a single AGC (signal) reading at the input of the Option 190 demodulator input and display it both as a hex value and as its equivalent 'gain' (for example, the amount of downconverter attenuation to subtract). With a signal at the input, by entering a value into `DNCVRTR ATTEN` and reading the AGC value returned by `{SHOW AGC VALUES}`, you can accomplish manually what the DLP automatic level setting algorithm does. Note that if you want to duplicate the value of attenuation shown during a measurement and the measurement set the analyzer attenuator (AT) to 0 dB, you'll also have to (manually) set AT to 0 dB.

The `AGC HOLD RUN` key allows you to freeze the AGC circuit when toggled to HOLD.

## Option 190 DVB-C Service Menus

### IQ Constellation

If **SHOW KEYS ON OFF** in the Service menus is set to ON, a **Service** key will be present in the IQ Constellation menu. All the keys on this **Service** menu are duplicates (for convenience) of keys under Service menu discussed in the menu sections, except **Osc Control**.

**Osc Control** leads to a menu which allows control of both the 240 MHz PLL and 71.1 MHz oscillators.

**PLL DFS - 0 +** is a 3-way toggle key. This key will offset the 240 MHz PLL oscillator by -200 KHz when a demod based measurement is started and the “-” is underlined or by +200 KHz when the “+” is underlined. This key is also a left-over from prototype days when we did not have control of the 71.1 MHz oscillator.

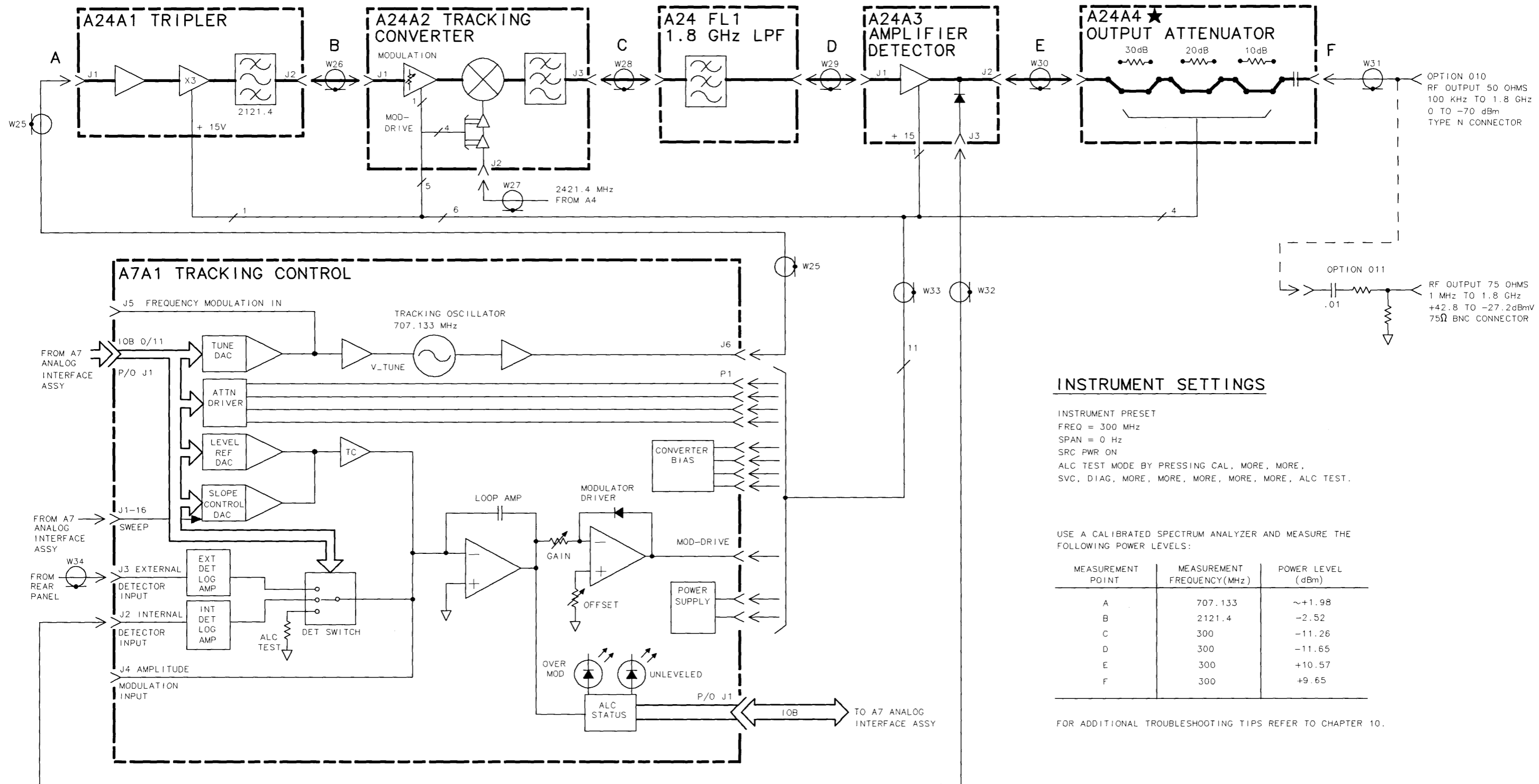
**PLL Custom** is also a left-over from prototype days and is a duplicate of the **Custom Freq** menu key described in the Downconverter Test section.

**TUNE 71.1 OSC** shows the current state of the 71.1 MHz oscillator and allows you to enter a new state (“tune number”). Note that even though the automatic retune algorithm will only select the lower (“1”), centered (“2”) or upper (“3”) states, you can enter values here from 0 to 7. The “0” state is twice as low as the “1” state, the “4” and “5” states are ‘don’t cares’, the “6” is twice as high as the “3” state and the “7” state is 3 times as high as the “3” state. It turned out that only the lower, centered, and upper states were required by the automatic retune algorithm to compensate for the temperature drift of the 71.1 oscillator.

**RETUNE ON OFF** is a duplicate of the same key in the Service menus described in the menu sections.

**SHOW SEQUENCE** will display the 71.1 MHz oscillator tune state numbers used during the last full signal acquisition sequence. A “2” means only tune state 2 was required. A “21” means that states 2 then 1 were tried. A “213” means that 2 then 1 then 3 were tried.





**INSTRUMENT SETTINGS**

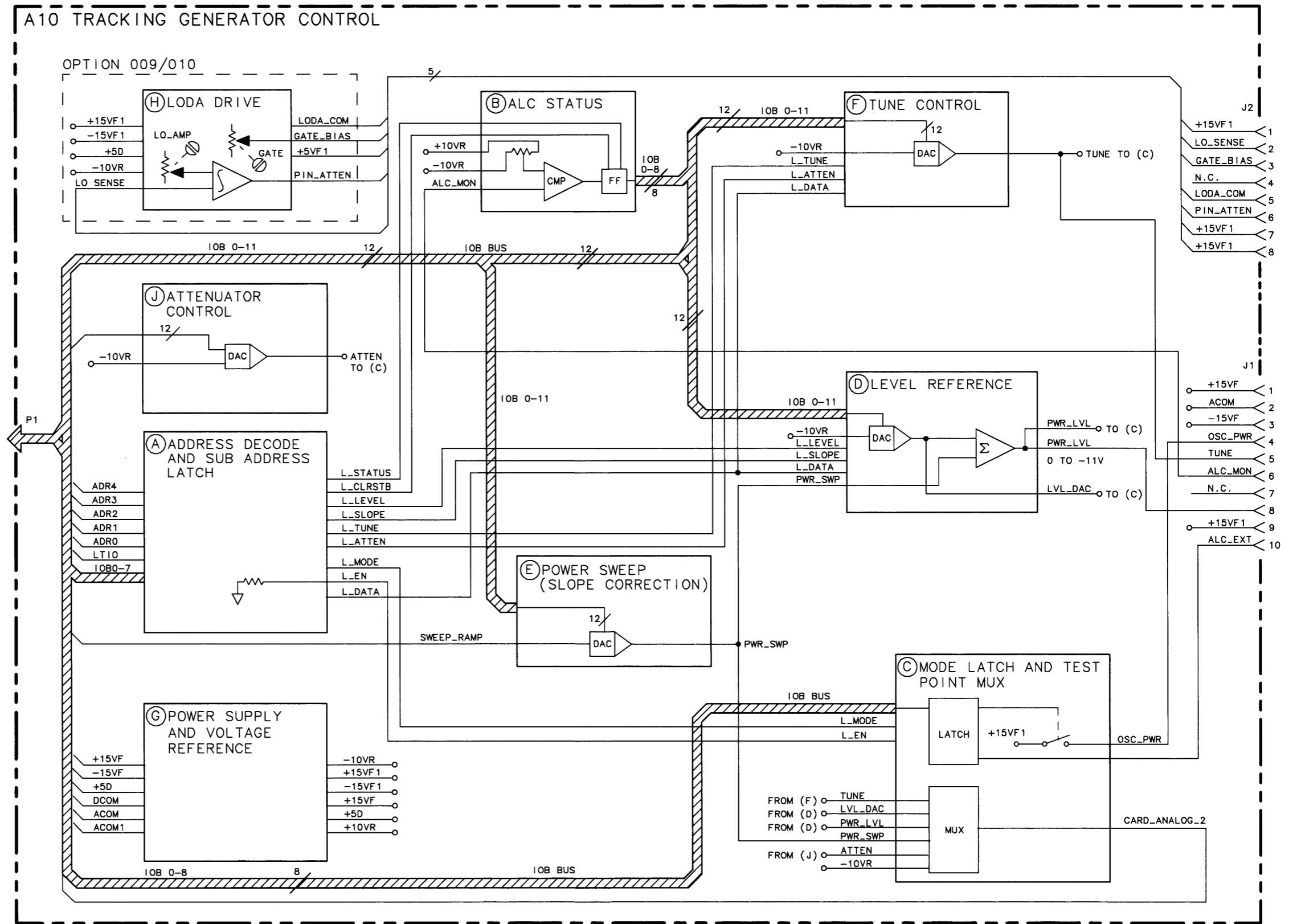
INSTRUMENT PRESET  
 FREQ = 300 MHz  
 SPAN = 0 Hz  
 SRC PWR ON  
 ALC TEST MODE BY PRESSING CAL, MORE, MORE,  
 SVC, DIAG, MORE, MORE, MORE, MORE, MORE, ALC TEST.

USE A CALIBRATED SPECTRUM ANALYZER AND MEASURE THE FOLLOWING POWER LEVELS:

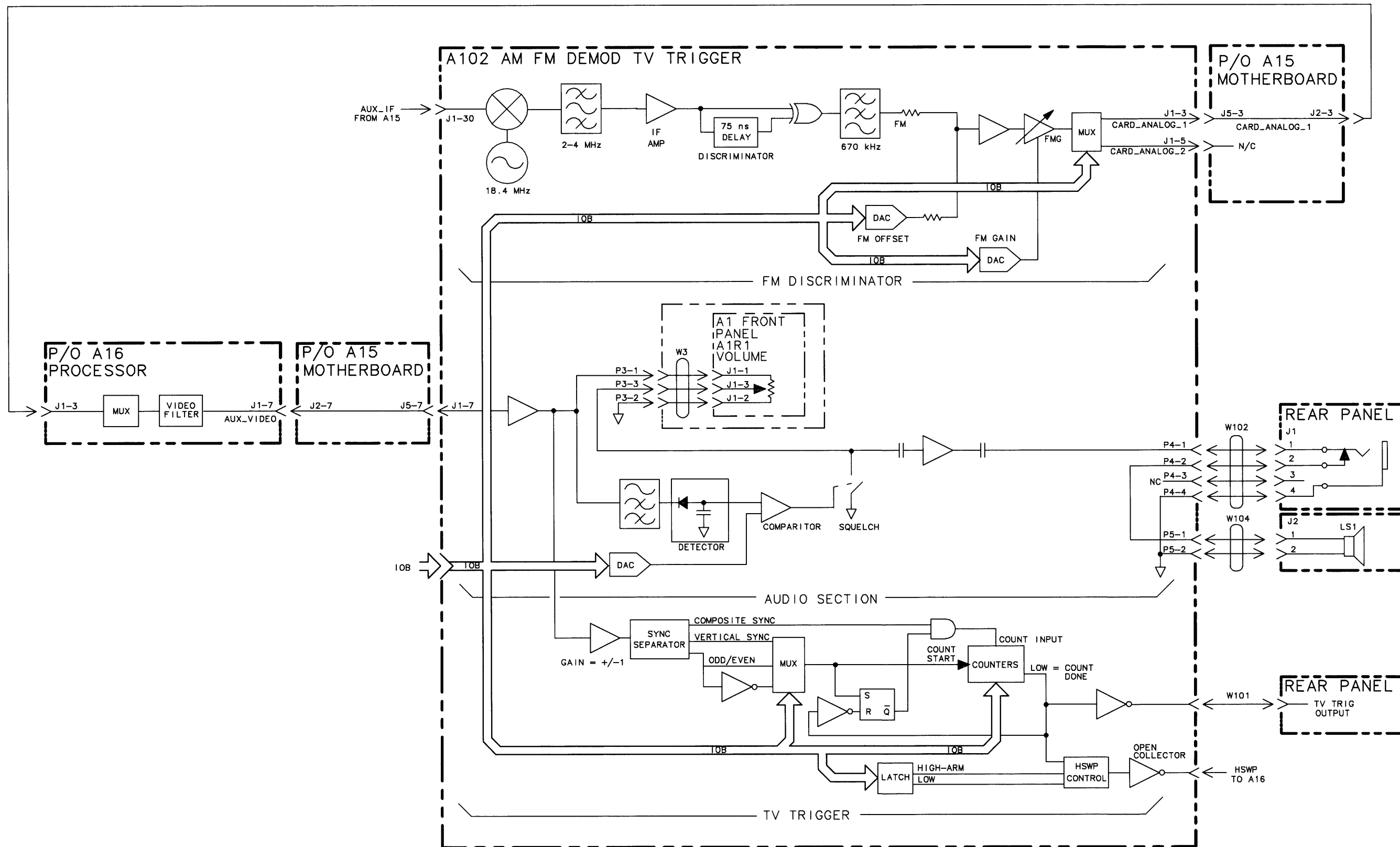
MEASUREMENT POINT	MEASUREMENT FREQUENCY (MHz)	POWER LEVEL (dBm)
A	707.133	~+1.98
B	2121.4	-2.52
C	300	-11.26
D	300	-11.65
E	300	+10.57
F	300	+9.65

FOR ADDITIONAL TROUBLESHOOTING TIPS REFER TO CHAPTER 10.

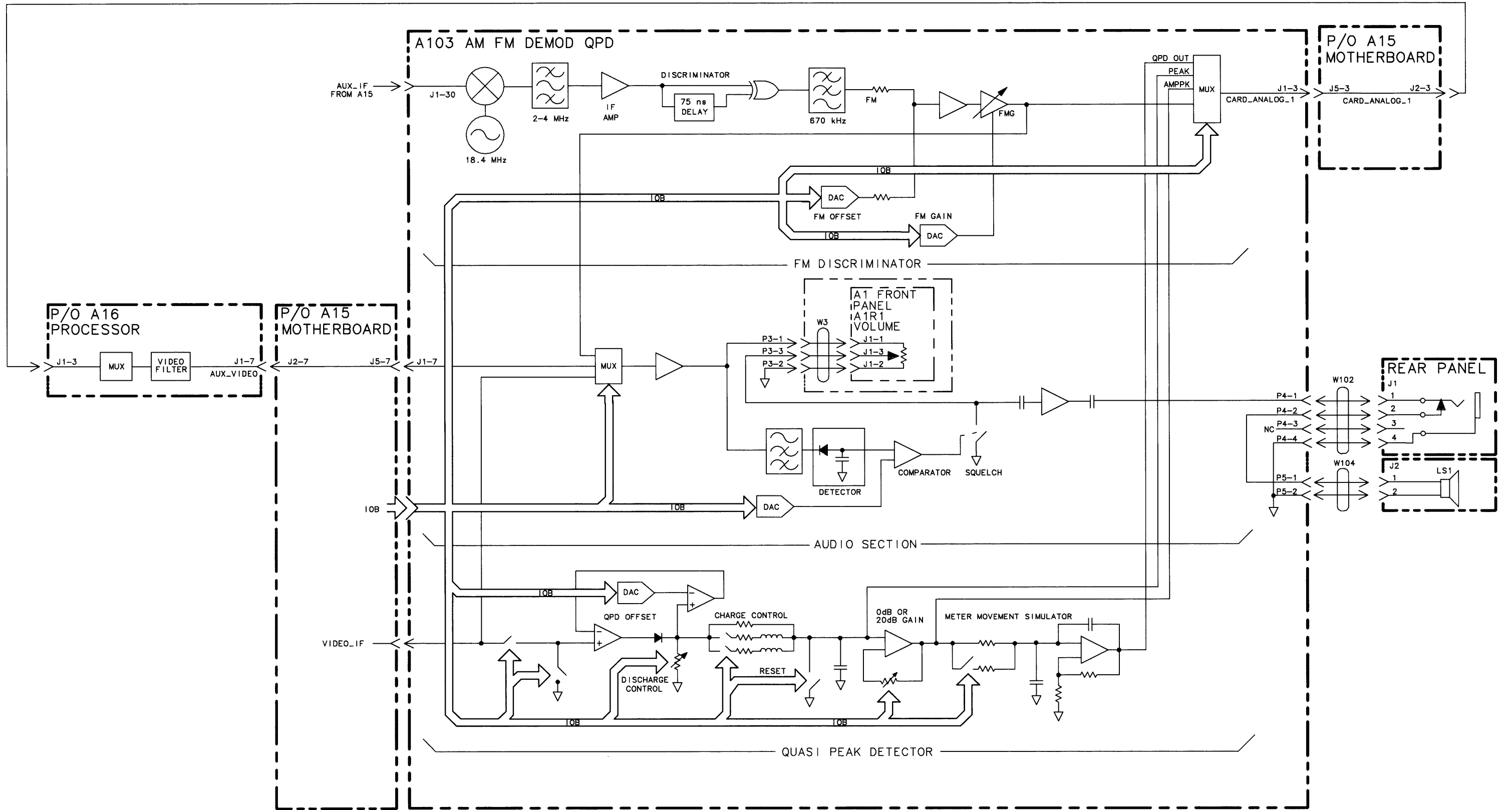
TRACKING GENERATOR CONTROL



sh2121e

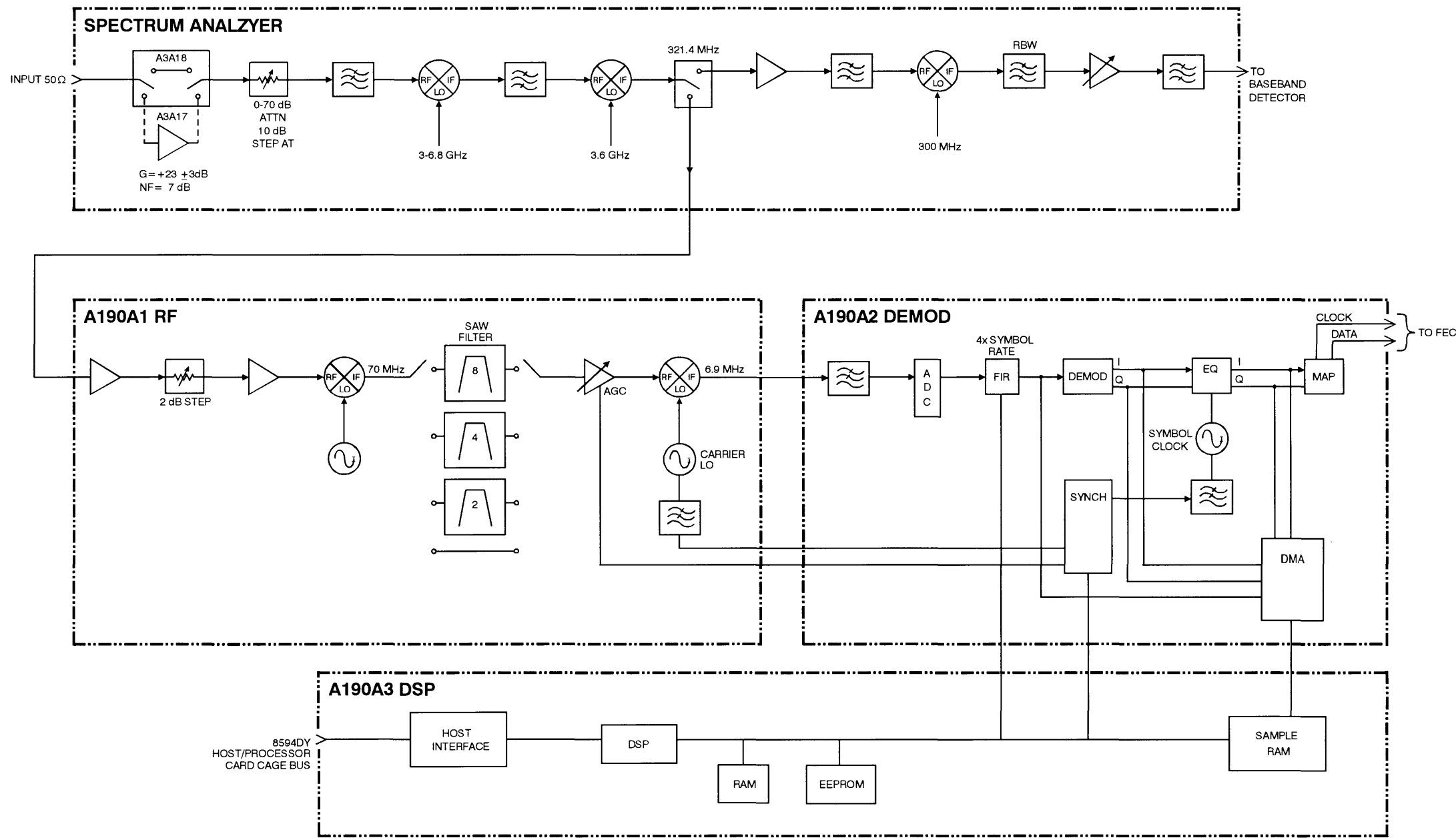


CARD CAGE OPTION



su114cel

HP 8594Q OPTION 190  
HARDWARE BLOCK DIAGRAM

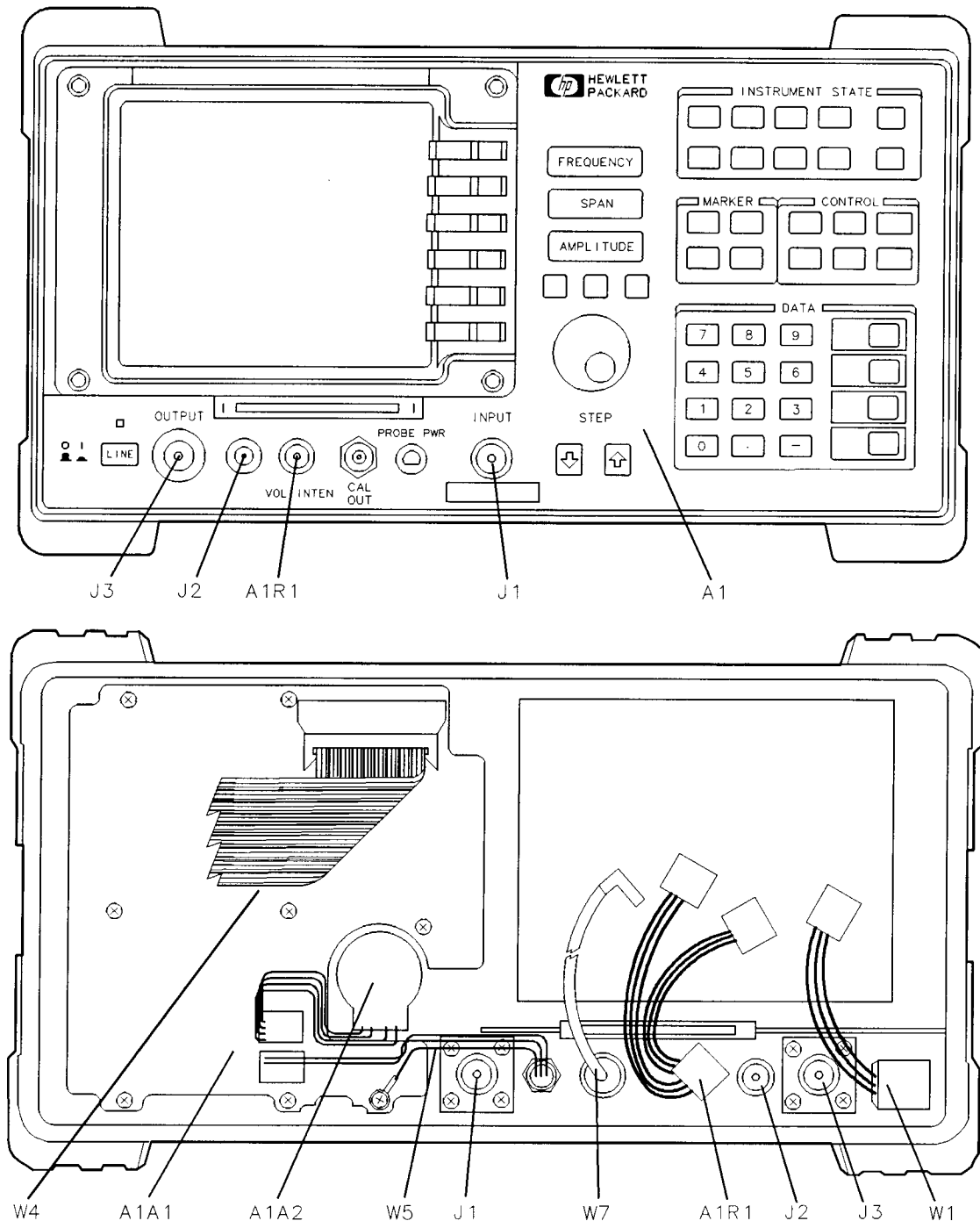


FOLDOUT 10-5. HP 8594Q OPTION 190 DVB-C QAM ANALYZER  
HARDWARE BLOCK DIAGRAM.

## **Major Assembly and Cable Locations**

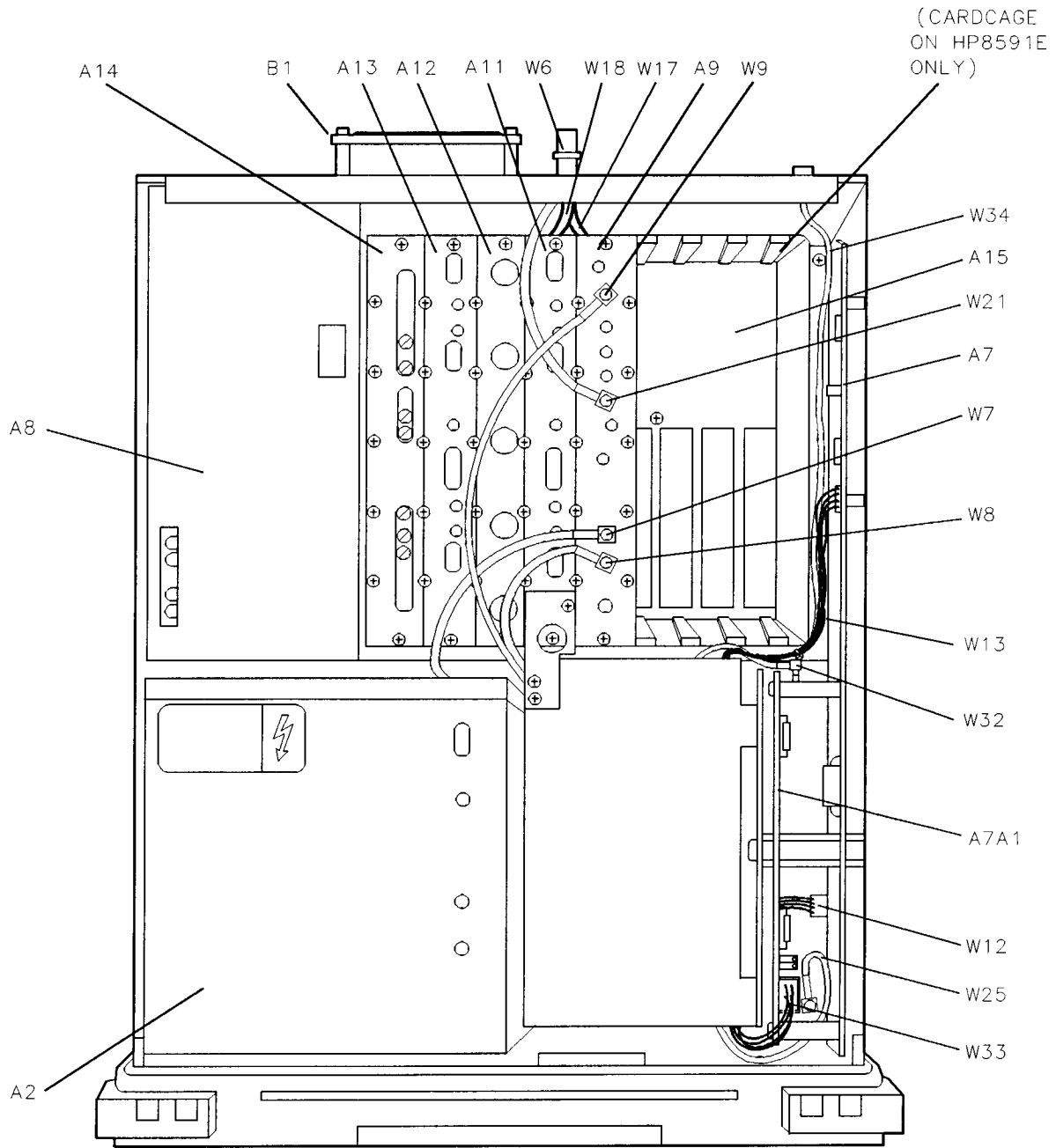
---

The various assemblies and cables of the HP 8590 E-Series and L-Series spectrum analyzers, HP 8591C cable TV analyzers, and HP 8594Q QAM analyzers are illustrated in this chapter. Refer to Chapter 12 for part numbers, assembly descriptions, and ordering information.



su11cde

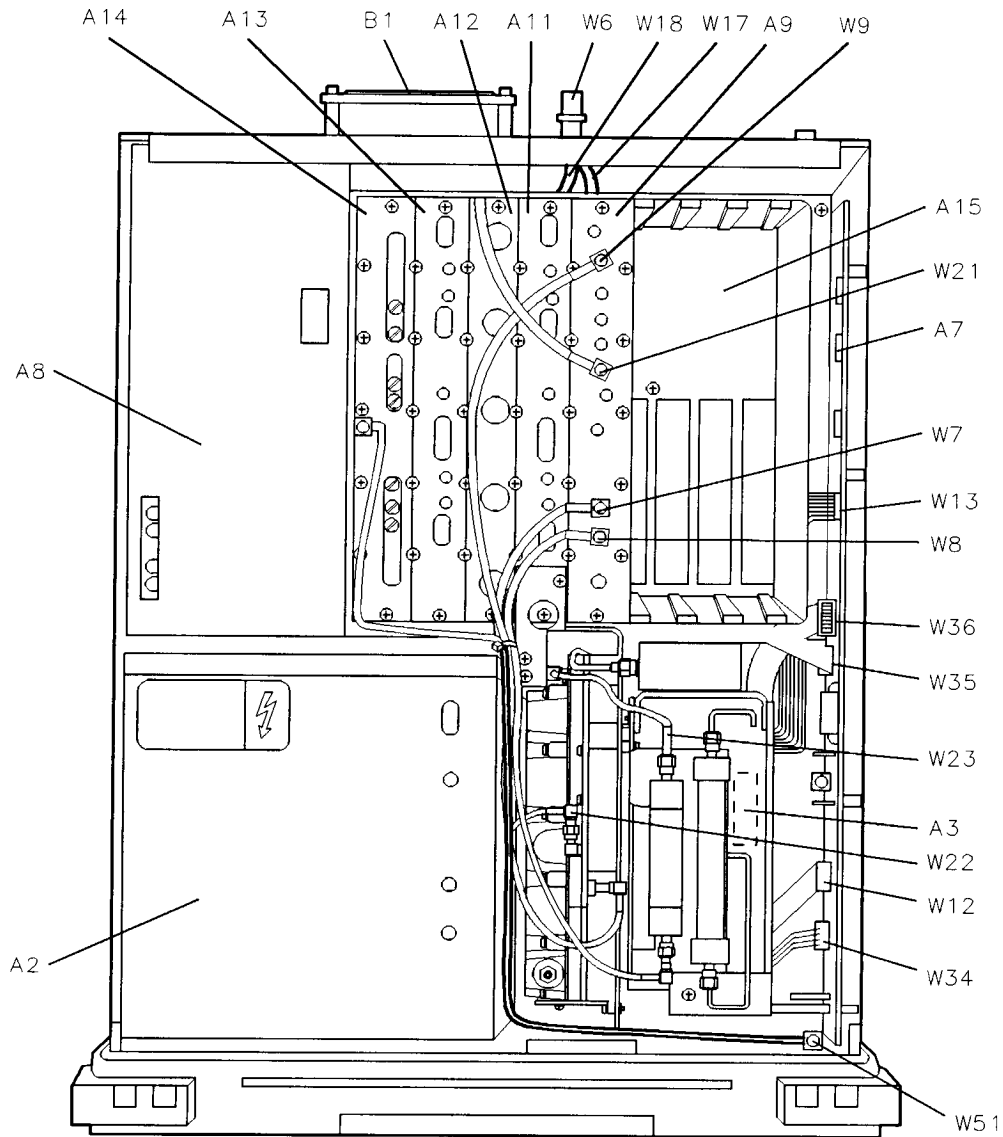
**Figure 11-1.**  
**A1 Front-Frame Assembly, Front and Rear Views**  
**HP 8590 E-Series and L-Series Spectrum Analyzers,**  
**HP 8591C Cable TV Analyzer, and HP 8594Q QAM Analyzers**



sh270e

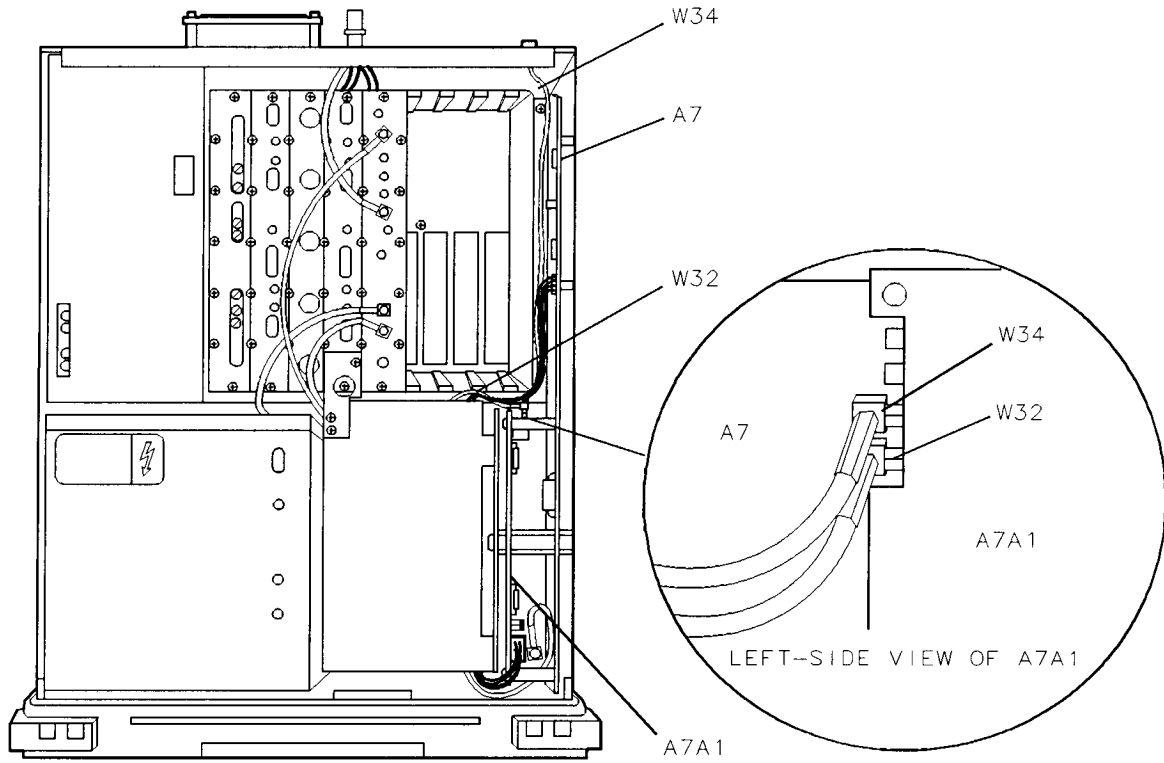
**Figure 11-2.**  
**Instrument Top View**  
**HP 8590L, HP 8591C, and HP 8591E**





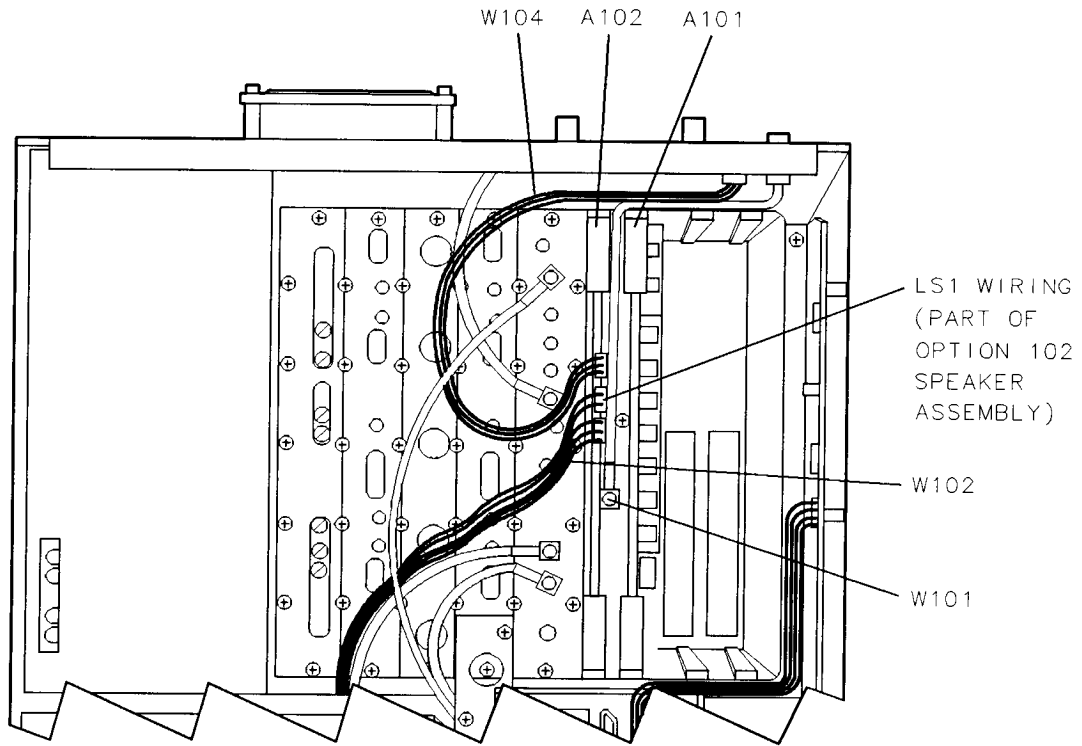
sh271e

**Figure 11-3.**  
**Instrument Top View**  
**HP 8592L, HP 8593E, HP 8594E, HP 8594L, HP 8594Q, HP 8595E, and HP 8596E**



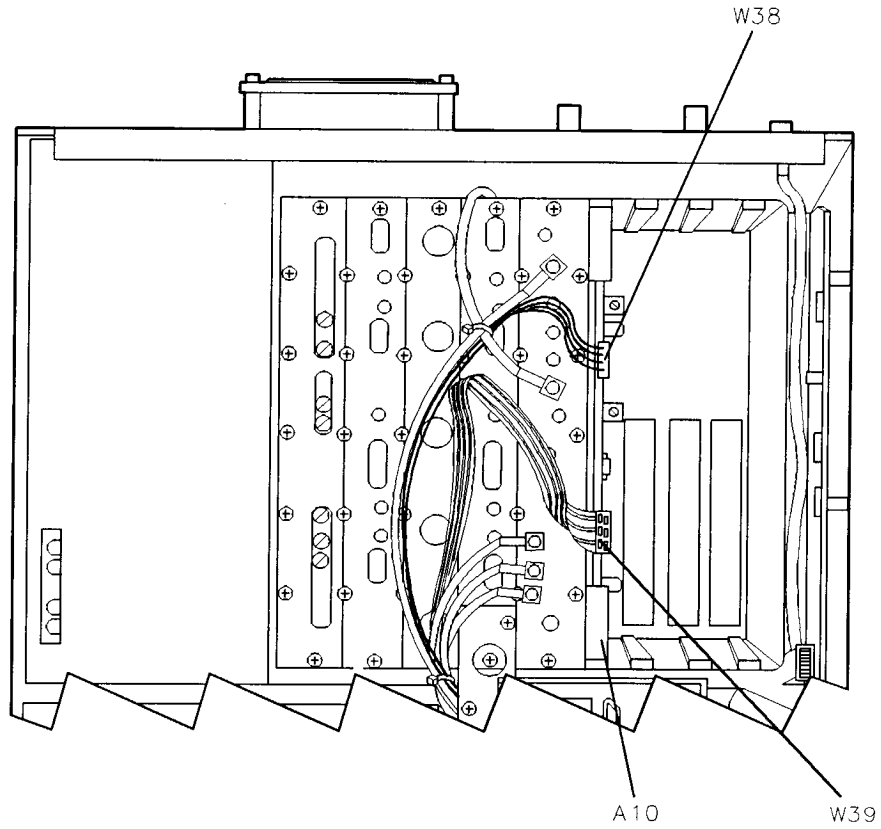
sh272e

**Figure 11-4.**  
**A7A1 Left-Side View**  
**HP 8590L, HP 8591C, and HP 8591E**



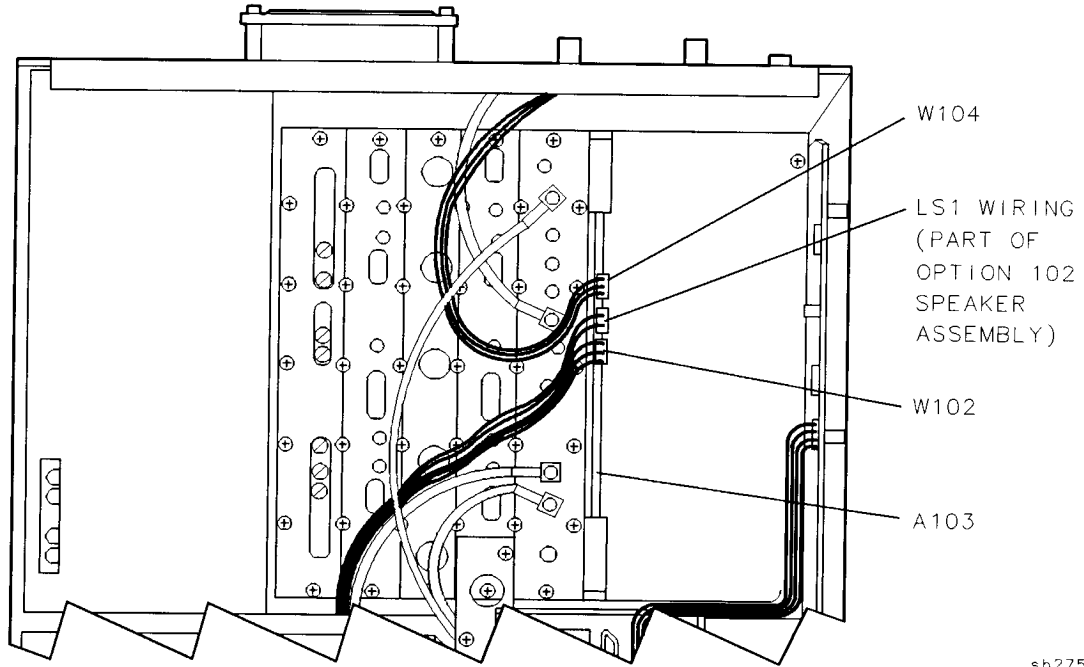
sh273e

**Figure 11-5.**  
**Card-Cage (Options 102, 103)**  
**HP 8590 E-Series, HP 8591C Cable TV Analyzers, and HP 8594Q QAM Analyzers**



sh274e

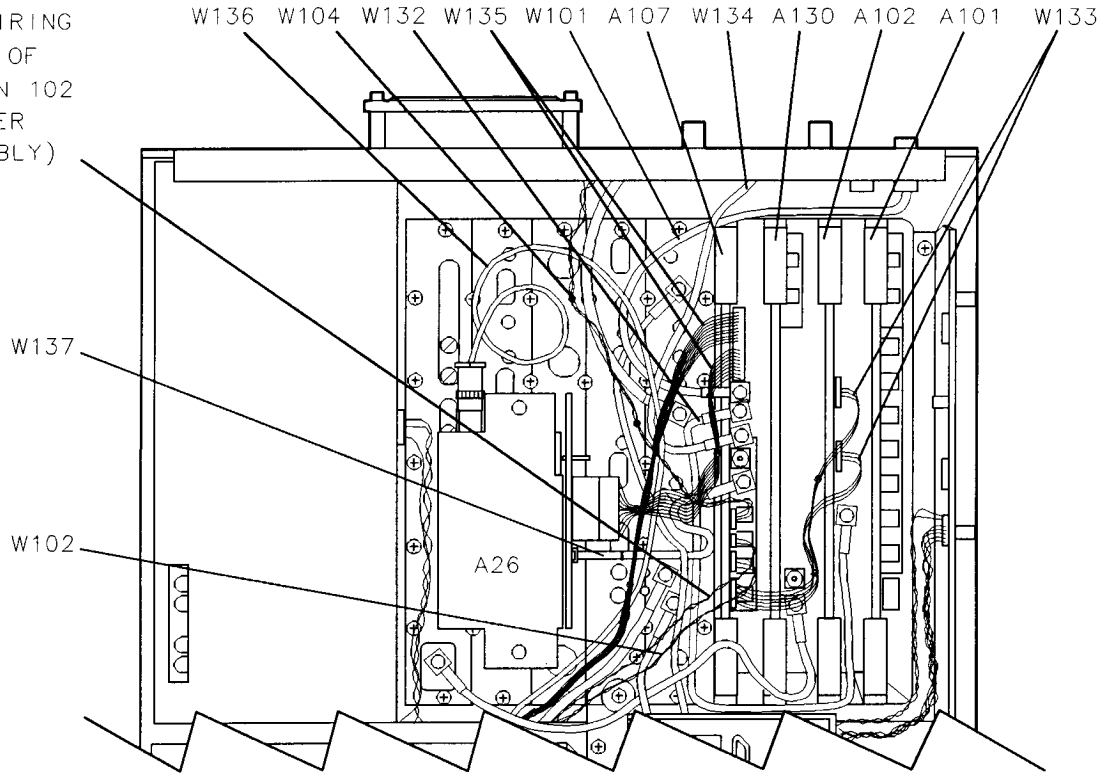
**Figure 11-6.**  
**Card-Cage (Options 009, 010)**  
**HP 8593E, HP 8594E, HP 8594Q, HP 8595E, and HP 8596E**



sh275e

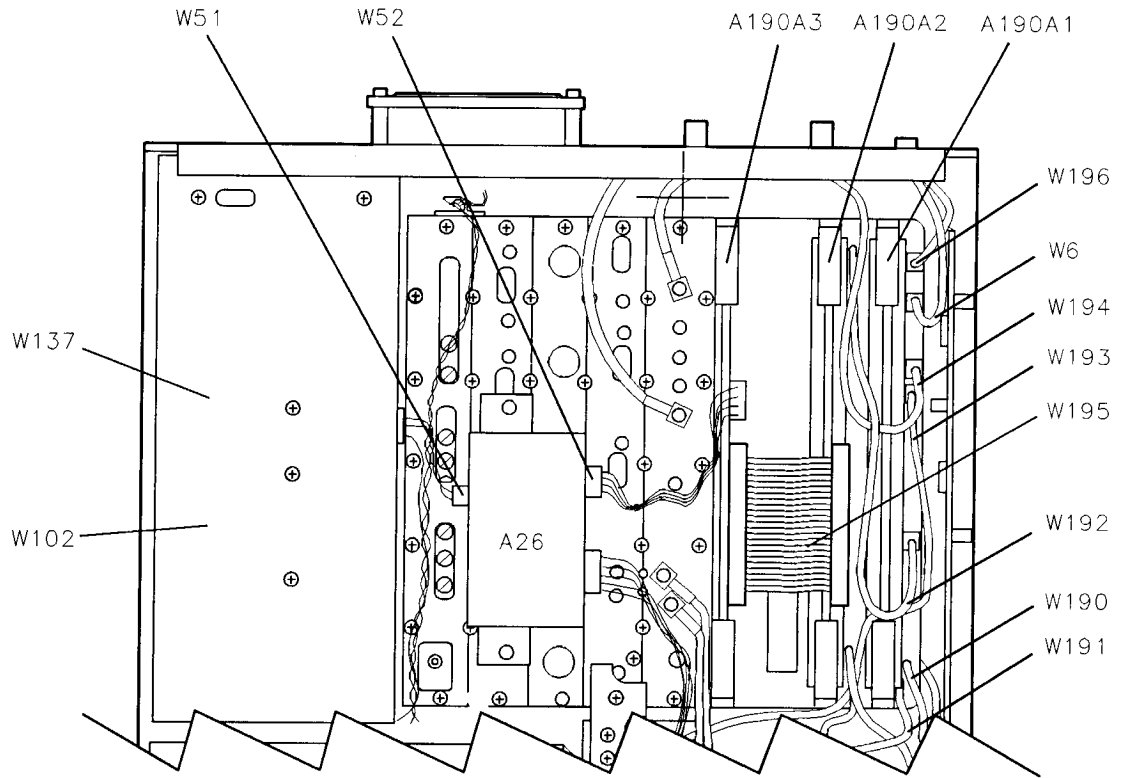
**Figure 11-7.**  
**Card-Cage (Option 103)**  
**HP 8590 E-Series**

LS1 WIRING  
(PART OF  
OPTION 102  
SPEAKER  
ASSEMBLY)



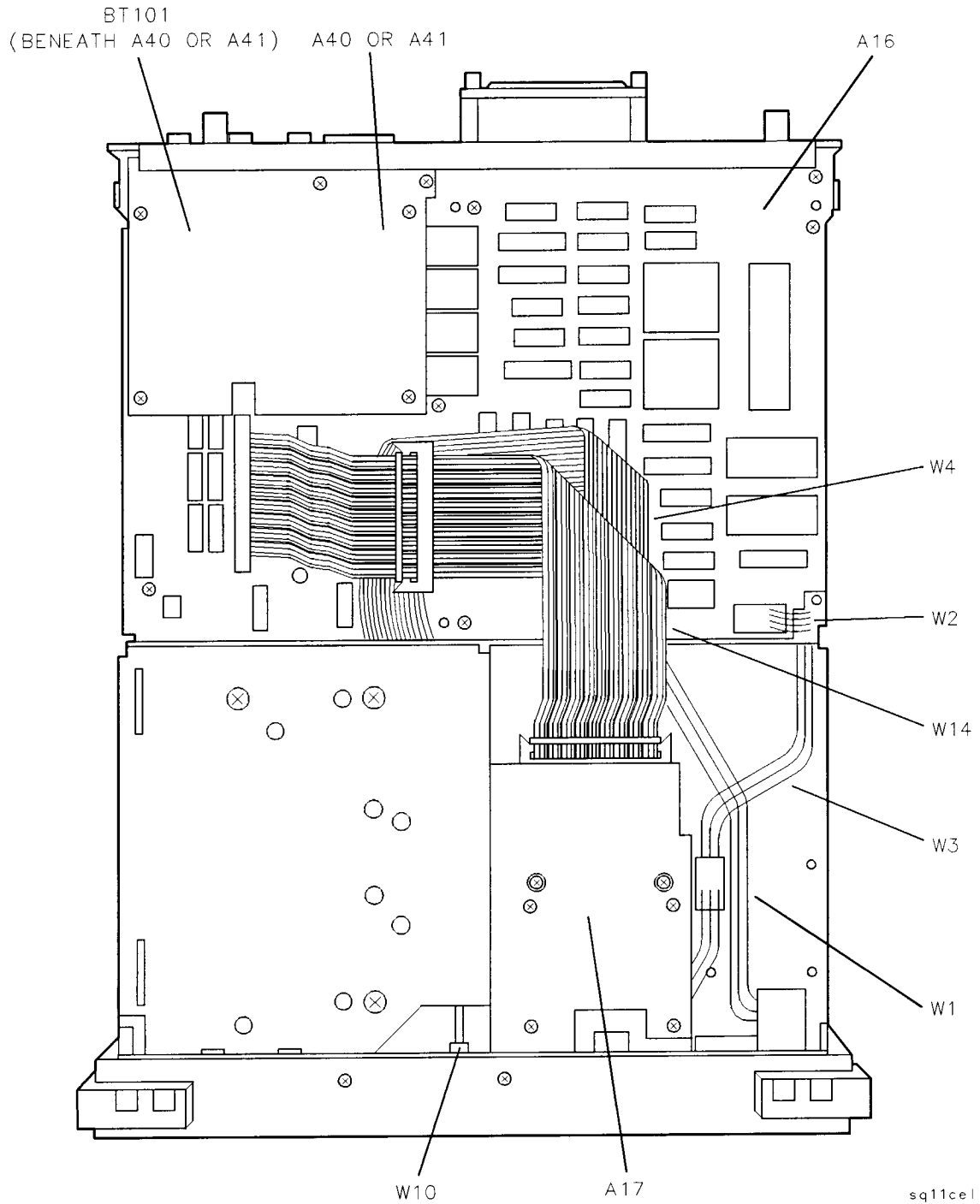
su111cde

**Figure 11-8.**  
**Card-Cage (Option 107)**  
**HP 8591C and HP 8590 E-Series**



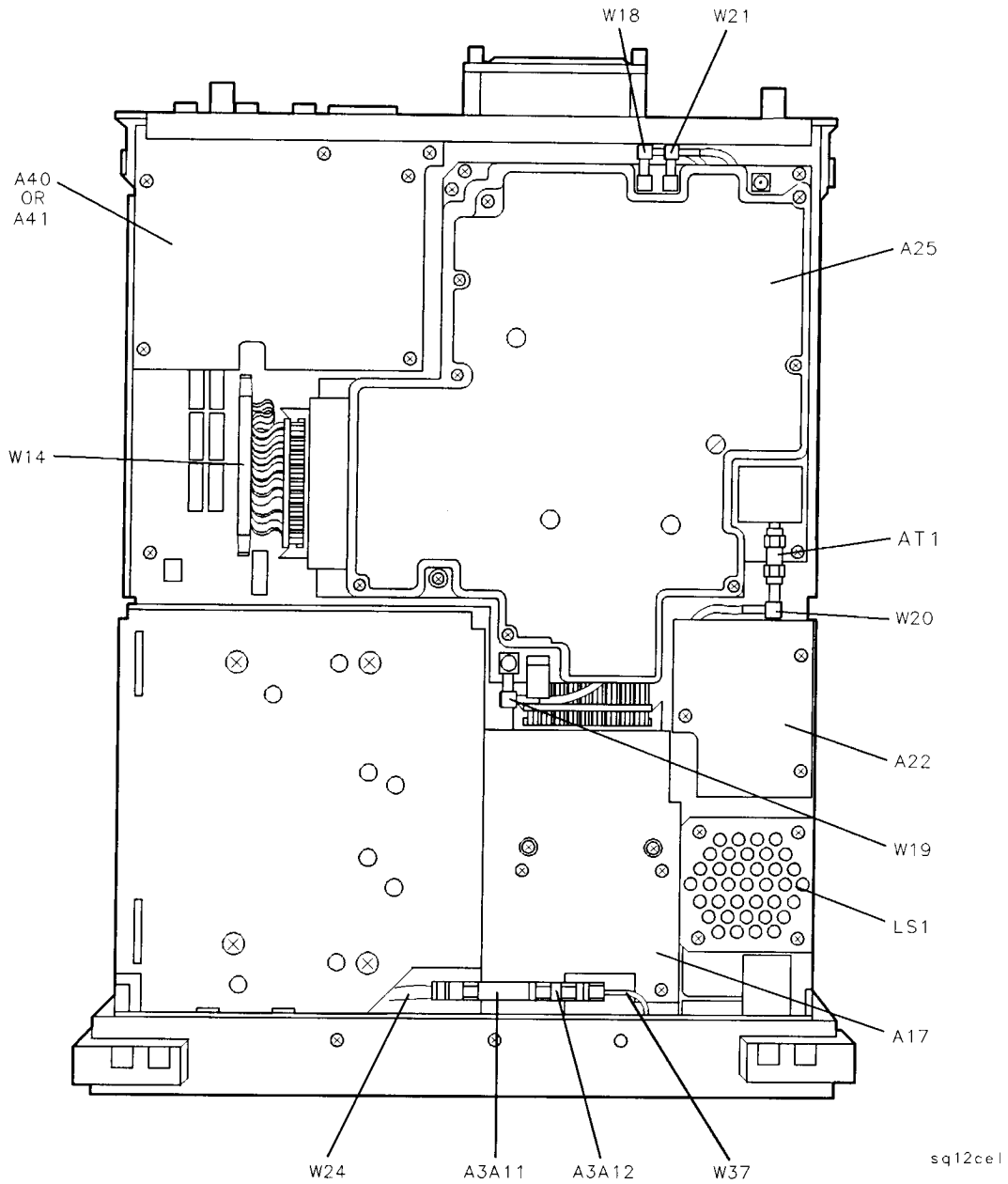
sq14

**Figure 11-9.**  
**Card-Cage (Option 190)**  
**HP 8594Q**

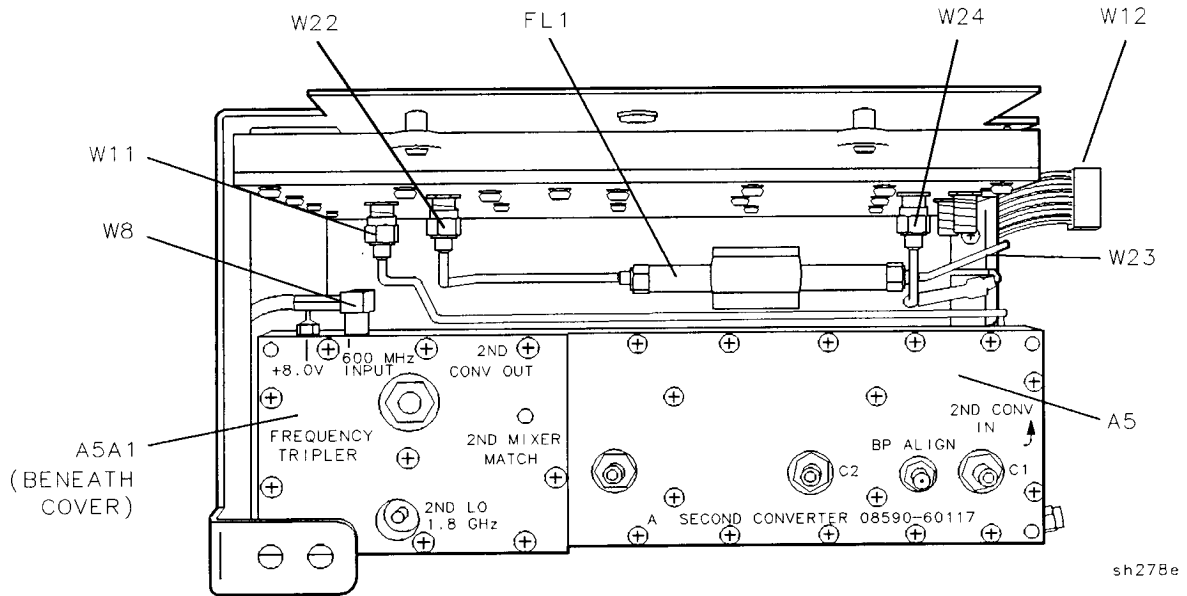


**Figure 11-10.**  
**Instrument Bottom View with A25 Counter-Lock Removed**  
**HP 8590 E-Series and L-Series Spectrum Analyzers,**  
**HP 8591C Cable TV Analyzer, and HP 8594Q QAM Analyzers**

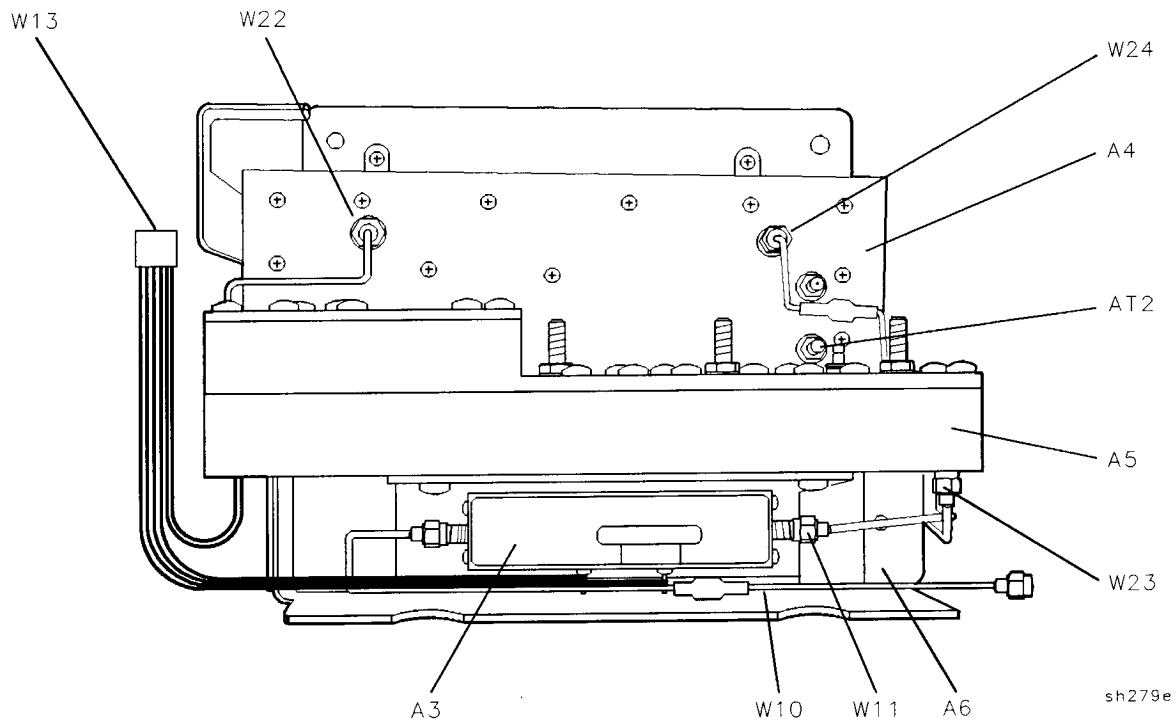




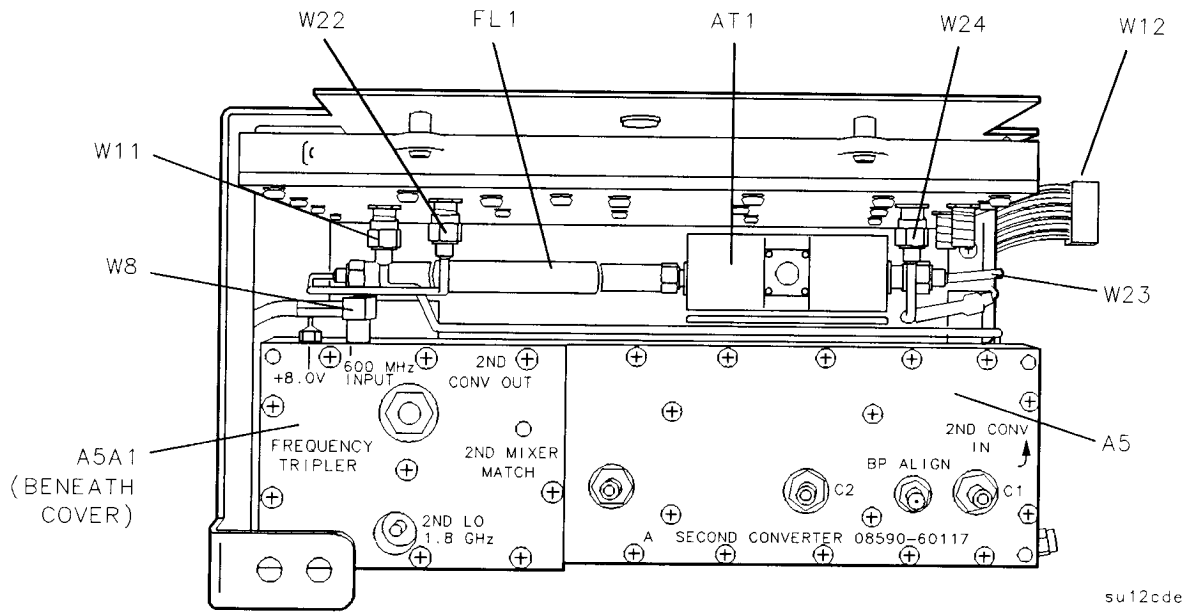
**Figure 11-11.**  
**Instrument Bottom View HP 8590 E-Series and L-Series Spectrum Analyzers,**  
**HP 8591C Cable TV Analyzers, and HP 8594Q QAM Analyzers**



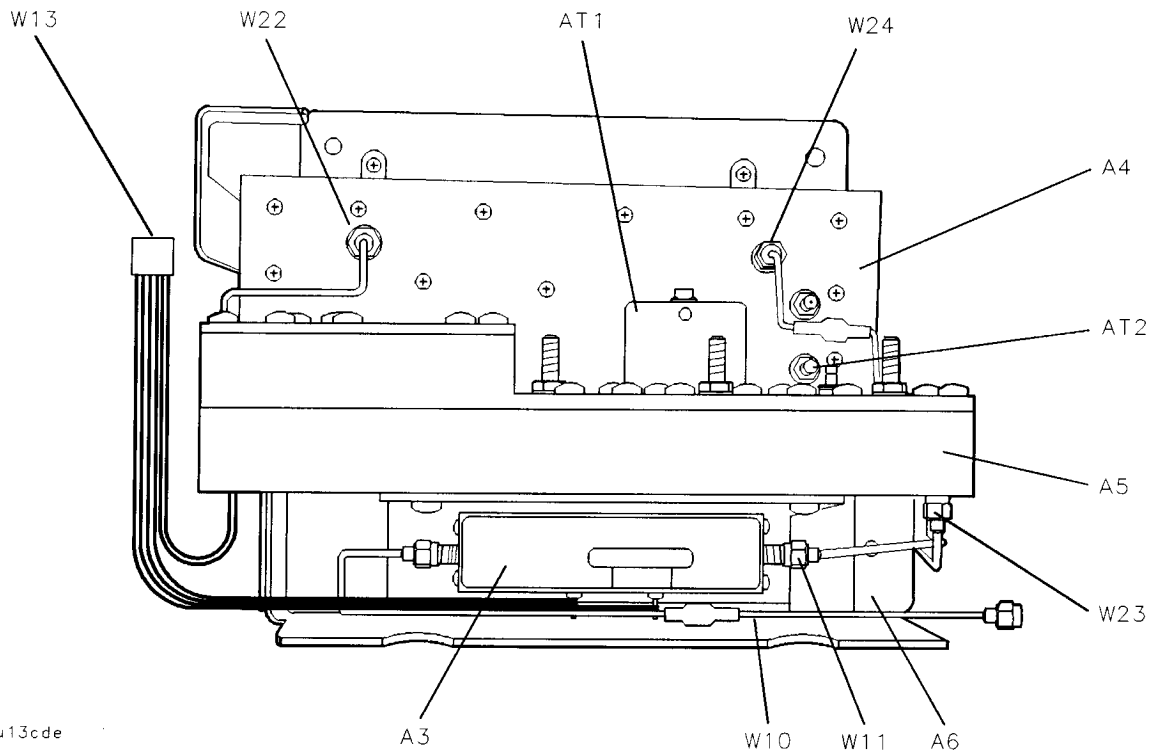
**Figure 11-12.**  
**Front-End Assembly, Top View**  
**HP 8590L and HP 8591E**



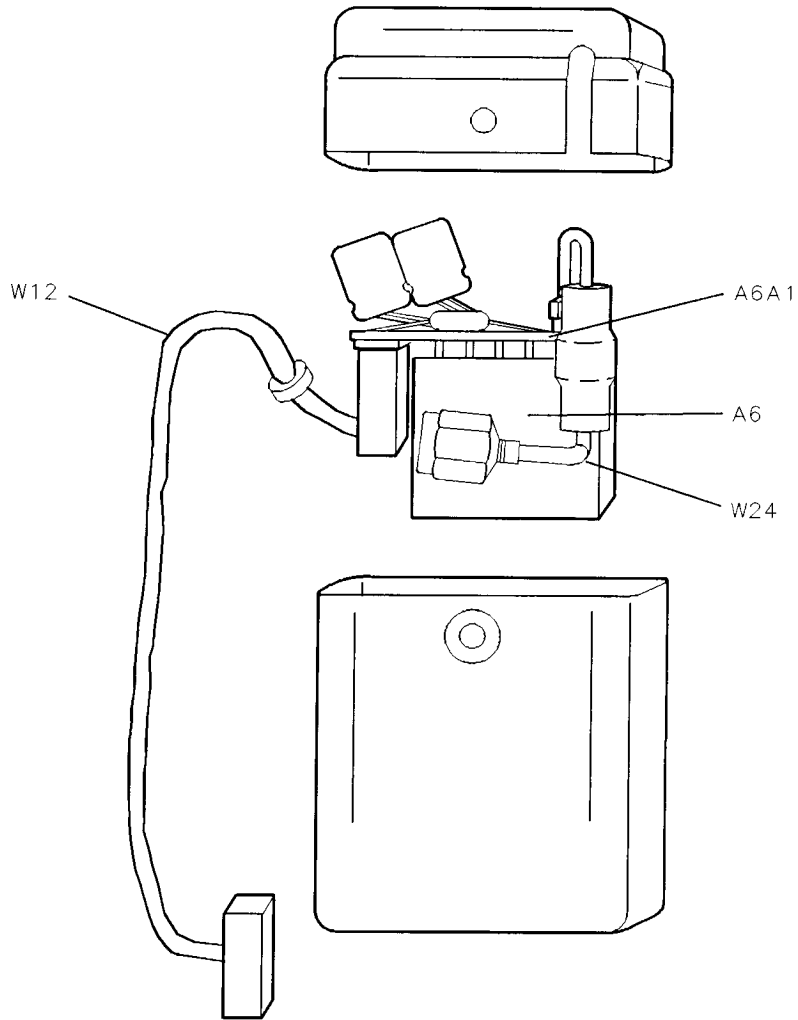
**Figure 11-13.**  
**Front-End Assembly, Left-Side View**  
**HP 8590L and HP 8591E**



**Figure 11-14.**  
**Front-End Assembly, Top View**  
**HP 8591C**

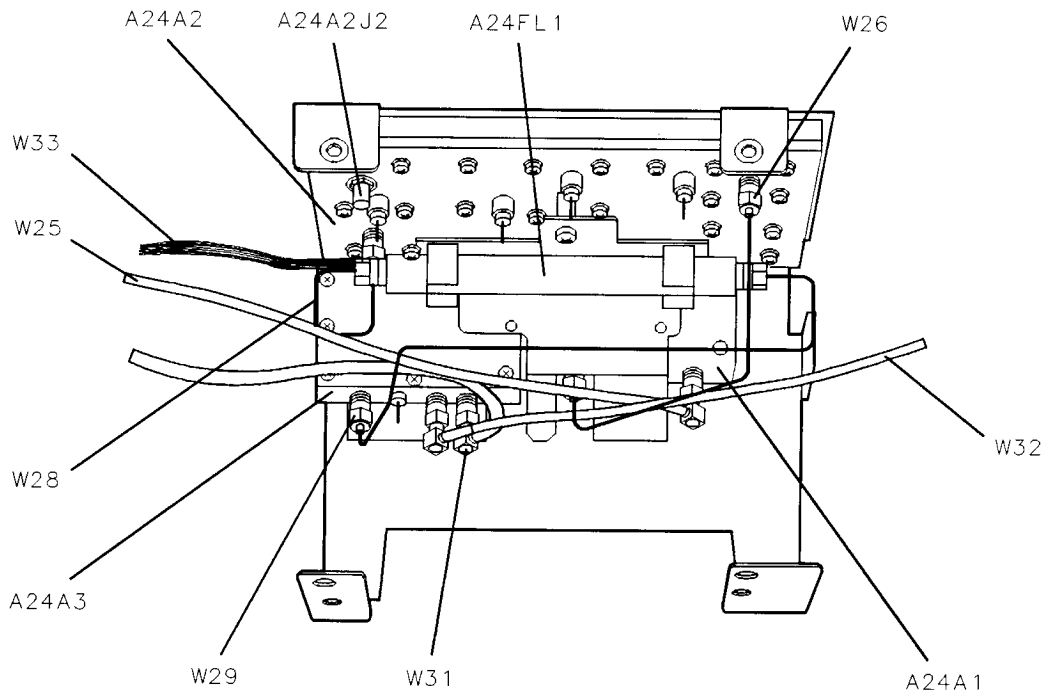


**Figure 11-15.**  
**Front-End Assembly, Left-Side View**  
**HP 8591C**



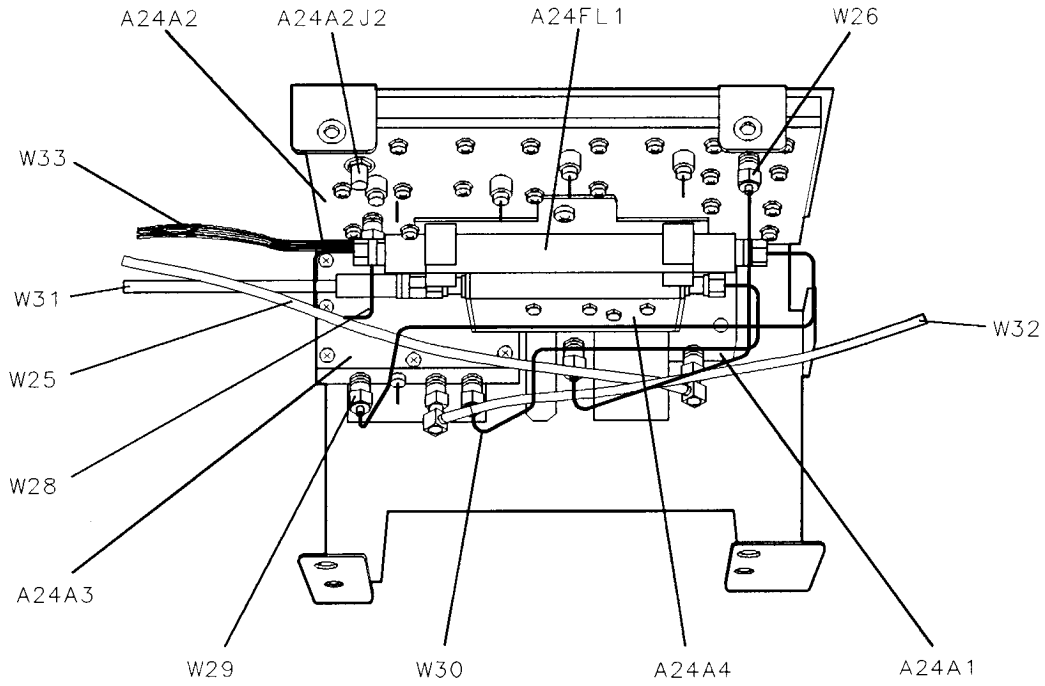
sh282e

**Figure 11-16.**  
**YTO Assembly**  
**HP 8590L, HP 8591C, and HP 8591E**



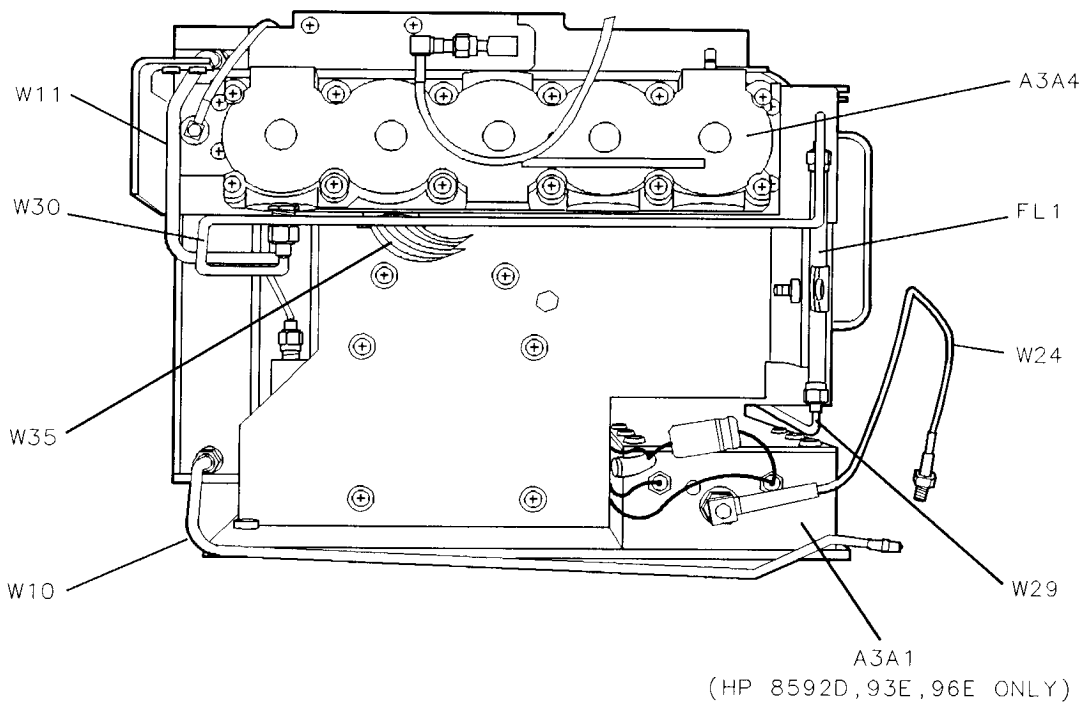
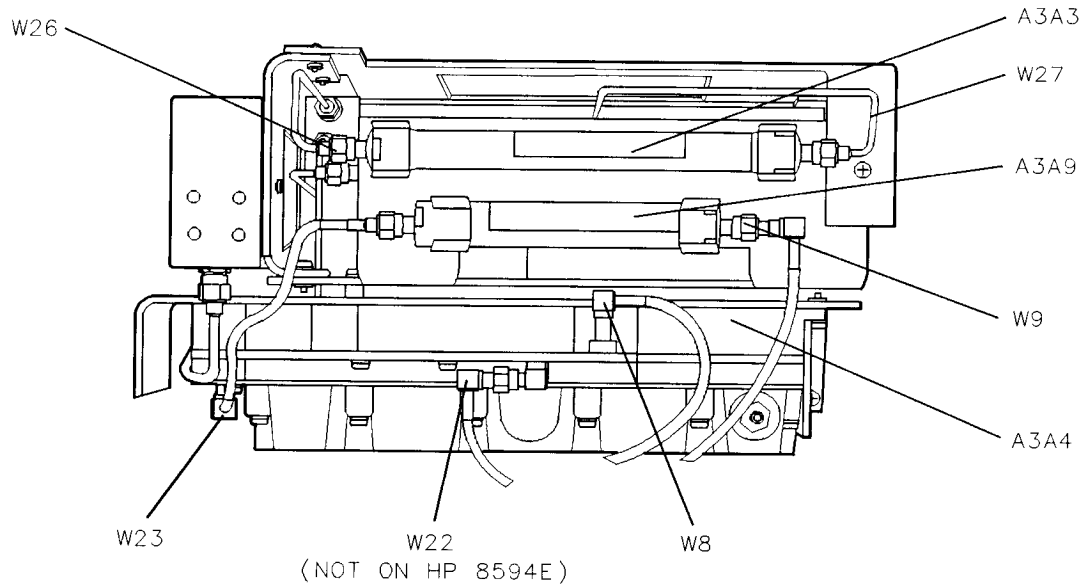
sh283e

**Figure 11-17.**  
**A24 Tracking Generator**  
**HP 8590L (Options 010 and 011)**



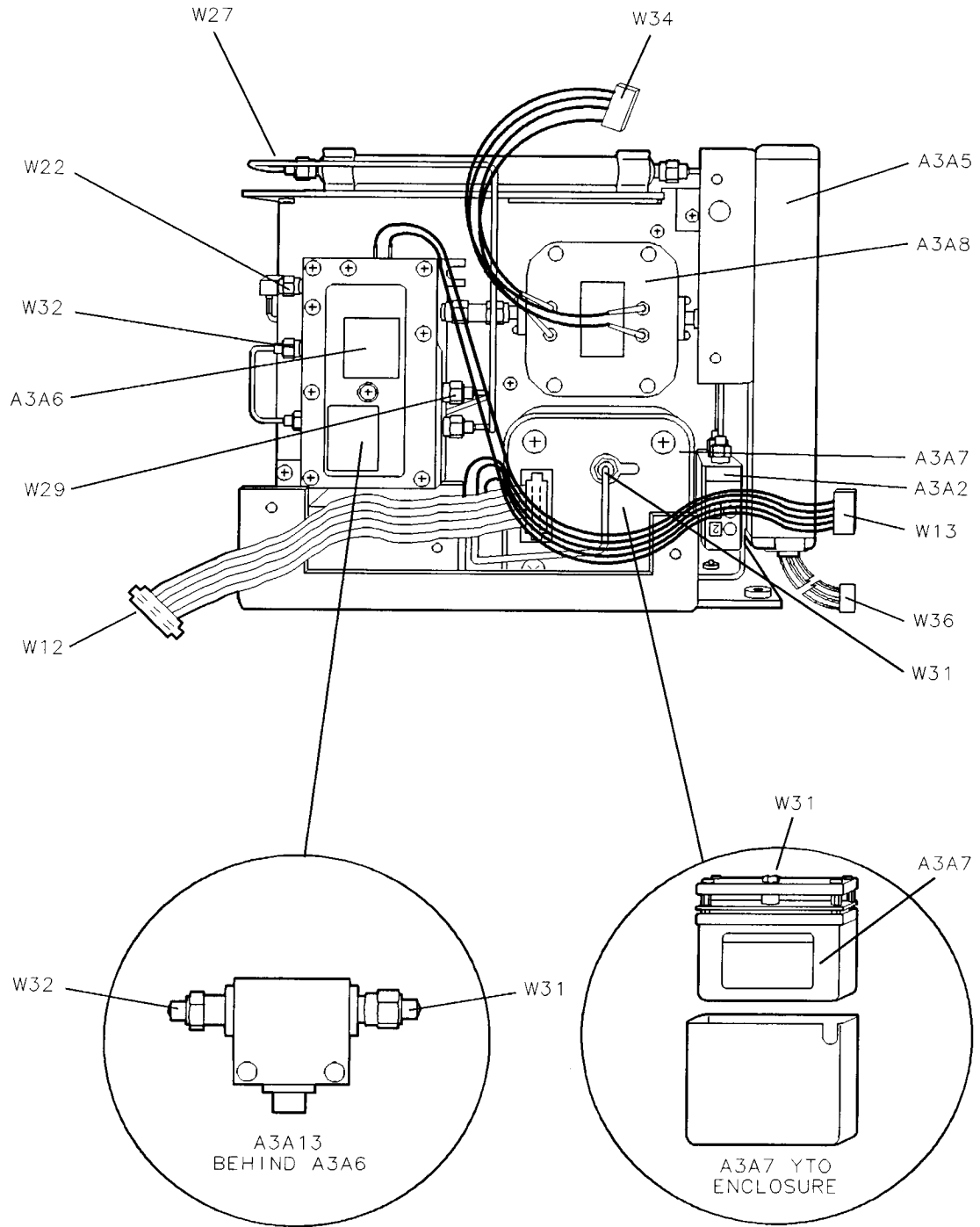
sh284e

**Figure 11-18.**  
**A24 Tracking Generator HP 8591C (Option 011)**  
**and HP 8591E (Options 010 and 011)**



sh285e

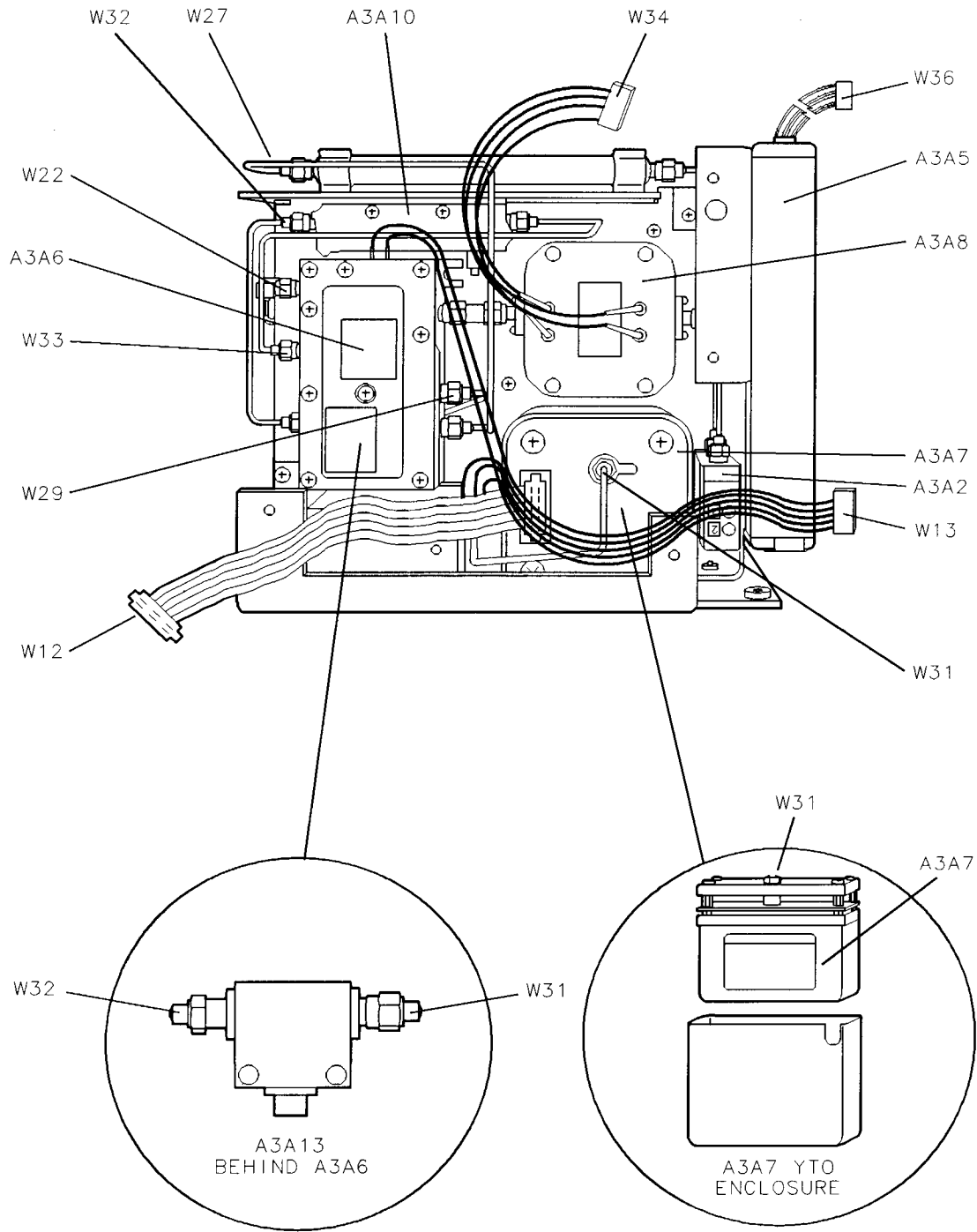
**Figure 11-19.**  
**A3 Front-End Assembly, Top and Left-Side Views**  
**HP 8592L, HP 8593E, HP 8594E, HP 8594L, HP 8594Q, HP 8595E, and HP 8596E**



sh286e

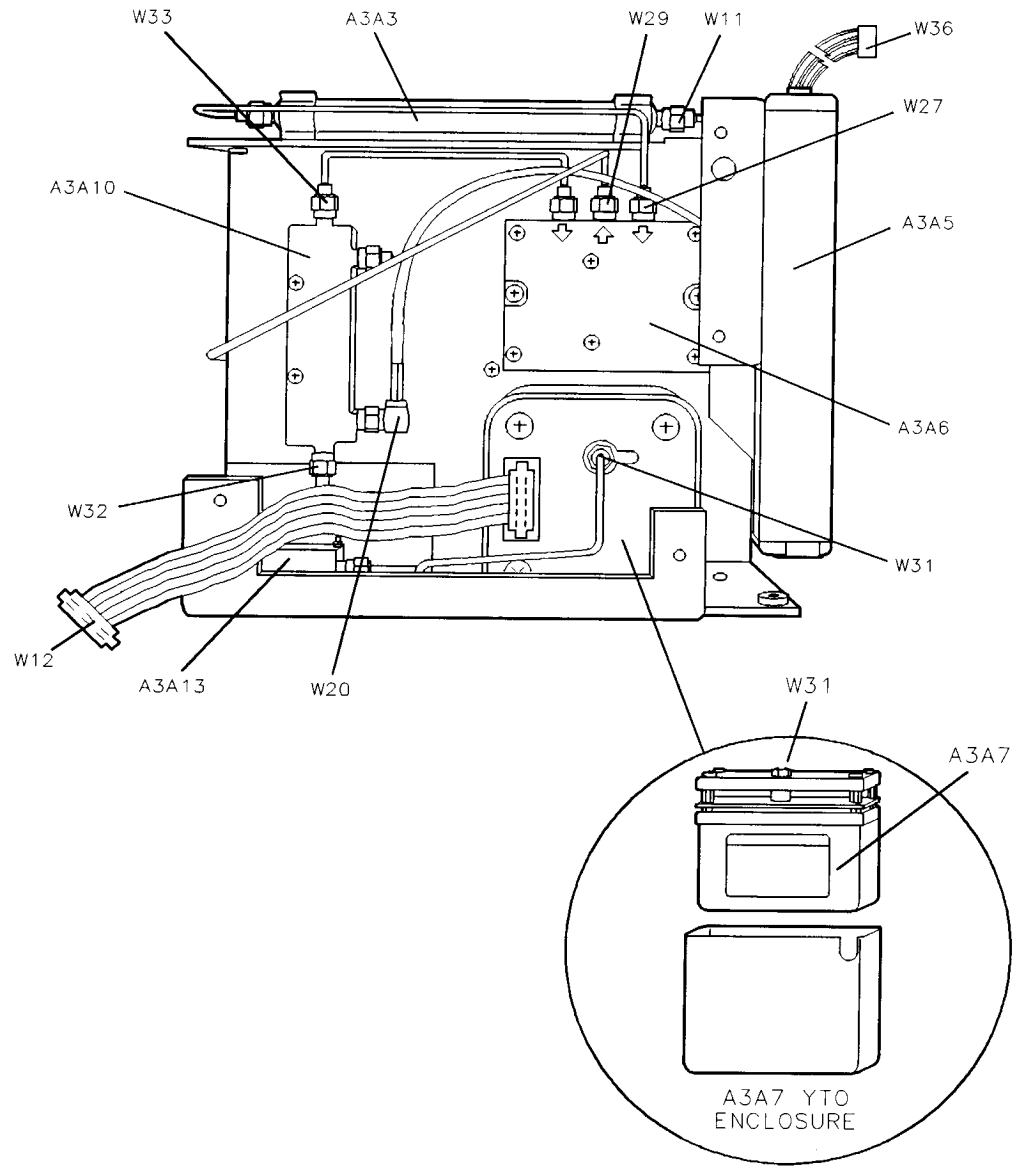
**Figure 11-20.**  
**A3 Front-End Assembly, Right-Side View**  
**HP 8592L**





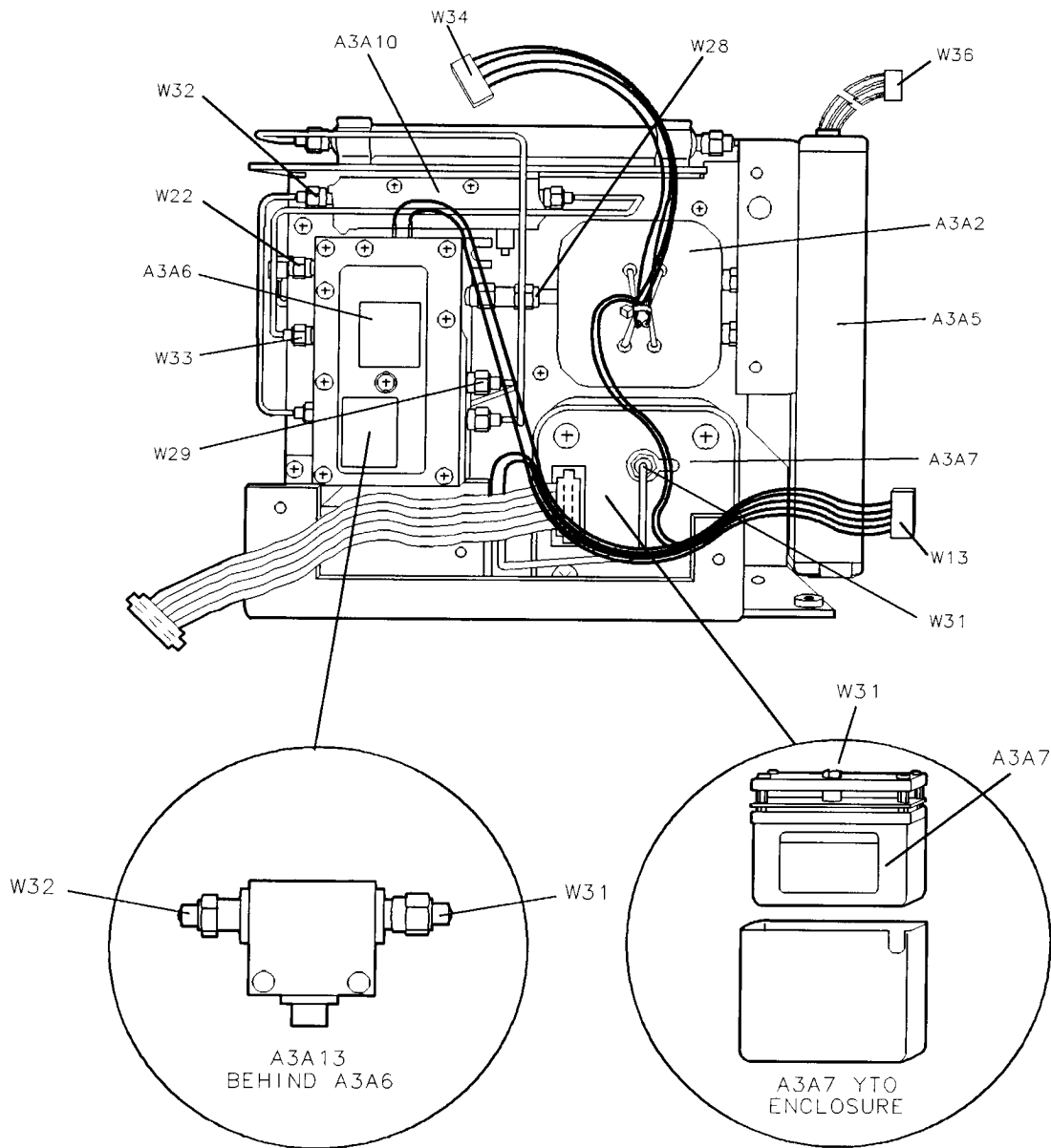
sh287e

**Figure 11-21.**  
**A3 Front-End Assembly, Right-Side View**  
**HP 8593E**



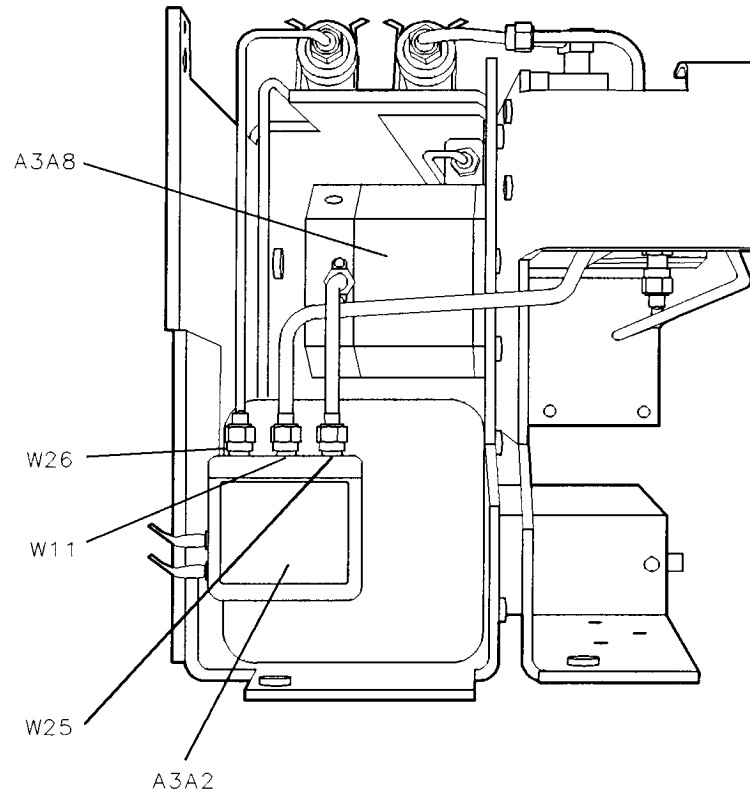
sh288e

**Figure 11-22.**  
**A3 Front-End Assembly, Right-Side View**  
**HP 8594E and HP 8594L**



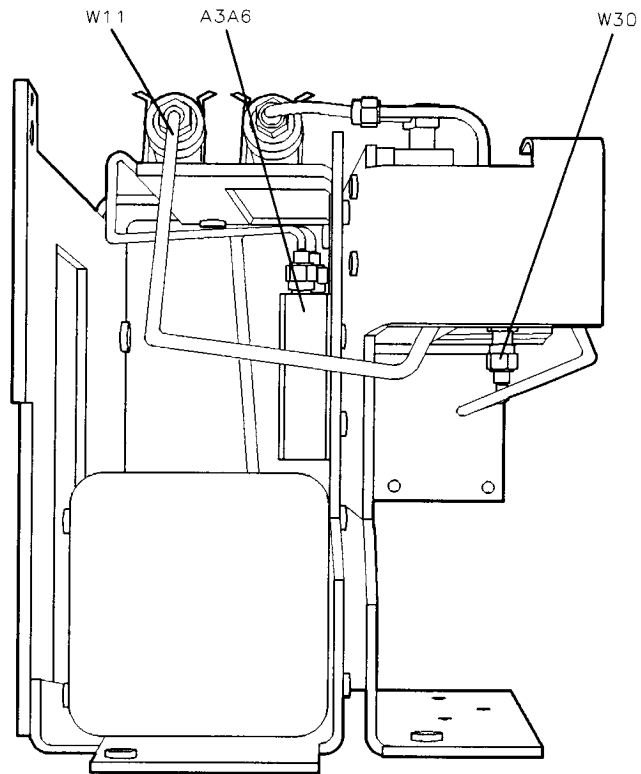
sh289e

**Figure 11-23.**  
**A3 Front-End Assembly, Right-Side View**  
**HP 8595E and HP 8596E**



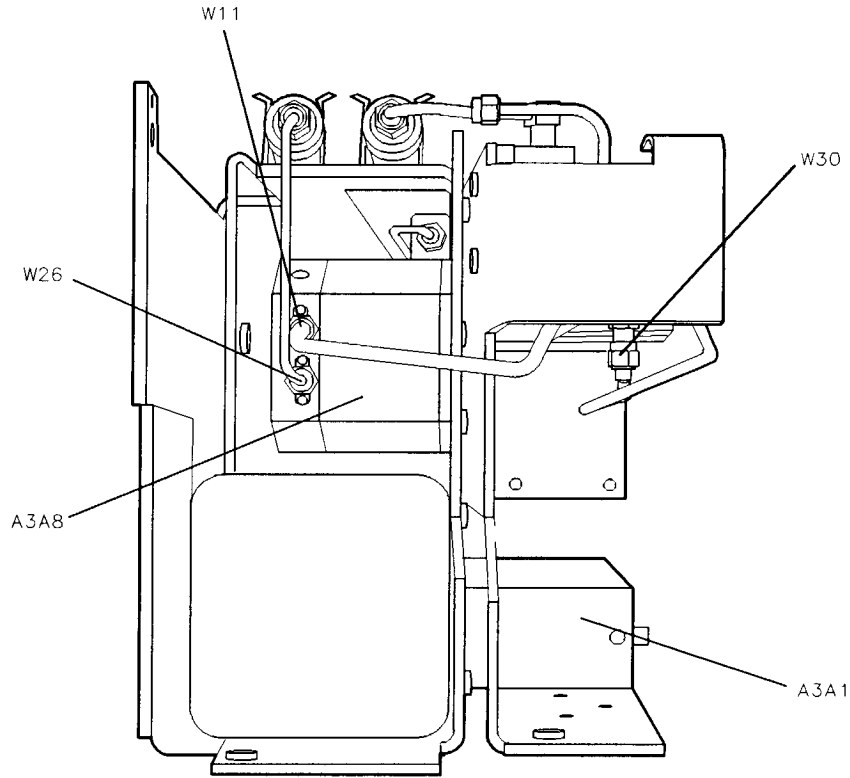
sh290e

**Figure 11-24.**  
**A3 Front-End Assembly, Rear View with A3A5 Removed**  
**HP 8592L and HP 8593E (Options 009 and 010)**



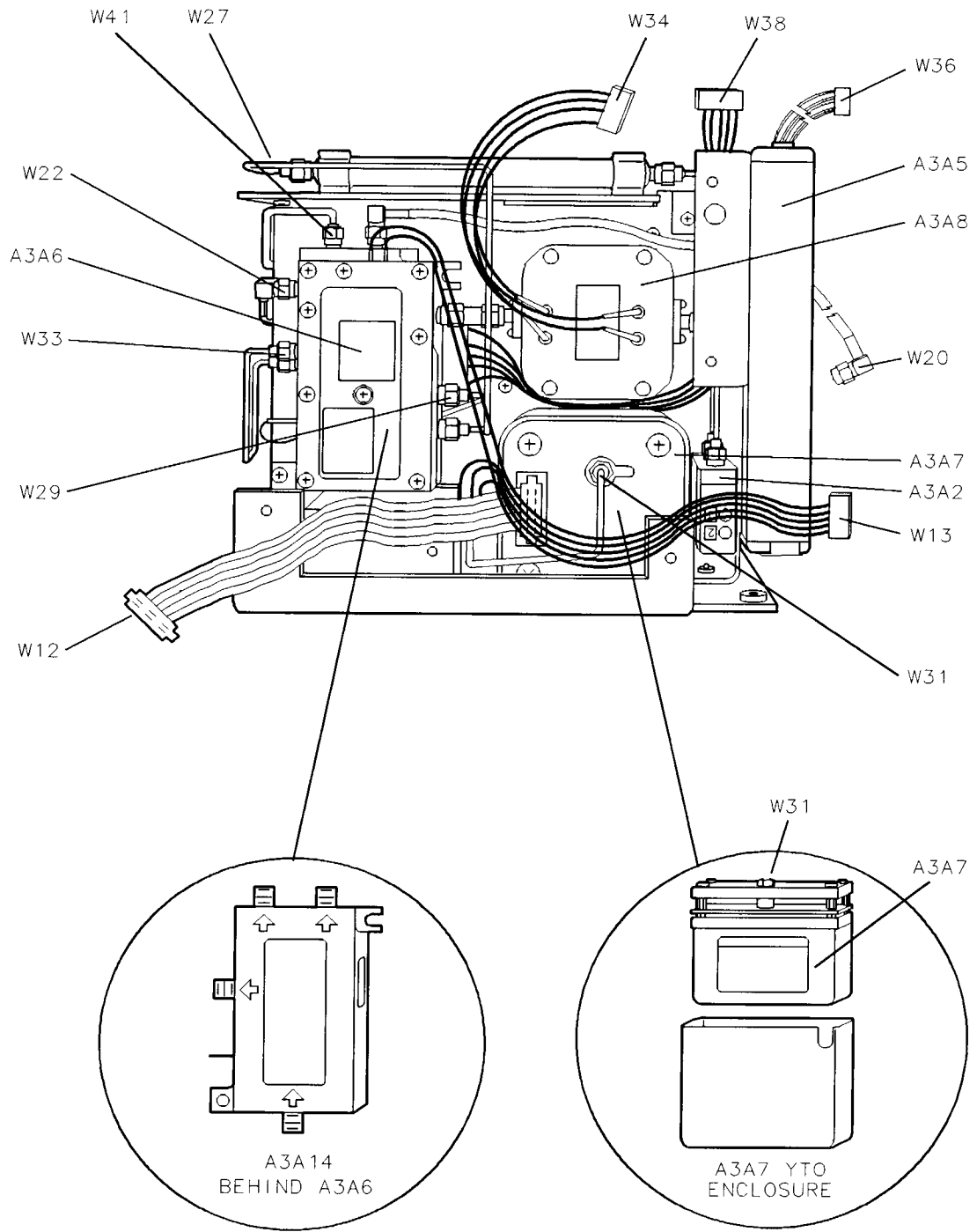
sh291e

**Figure 11-25.**  
**A3 Front-End Assembly, Rear View with A3A5 Removed**  
**HP 8594E (Options 009 and 010)**



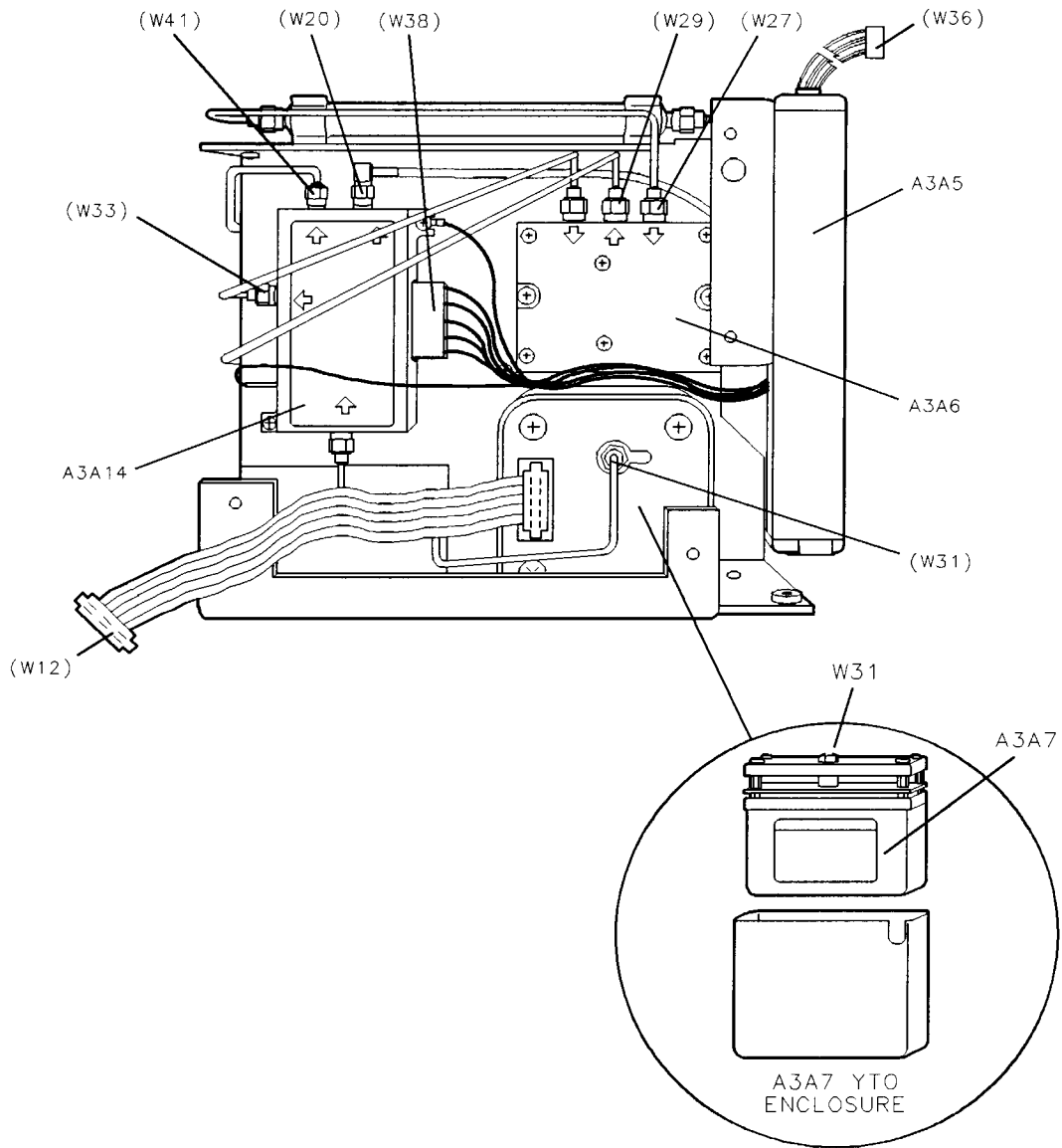
sh292e

**Figure 11-26.**  
**A3 Front-End Assembly,**  
**Rear View with A3A5 Removed**  
**HP 8595E and HP 8596E (Options 009 and 010)**



sh293e

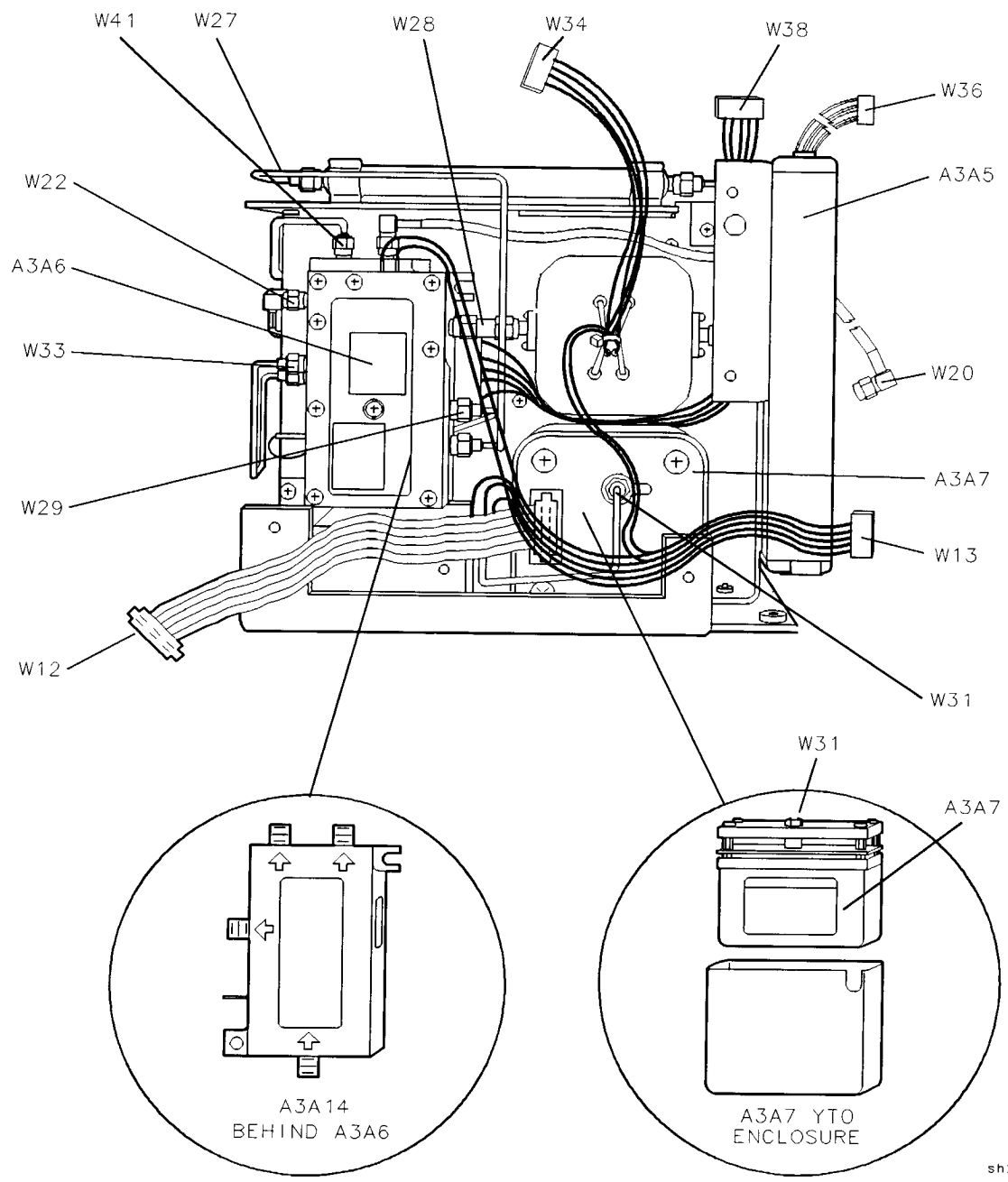
**Figure 11-27.**  
**A3 Front-End Assembly, Right-Side View**  
**HP 8593E (Options 009 and 010)**



sh294e

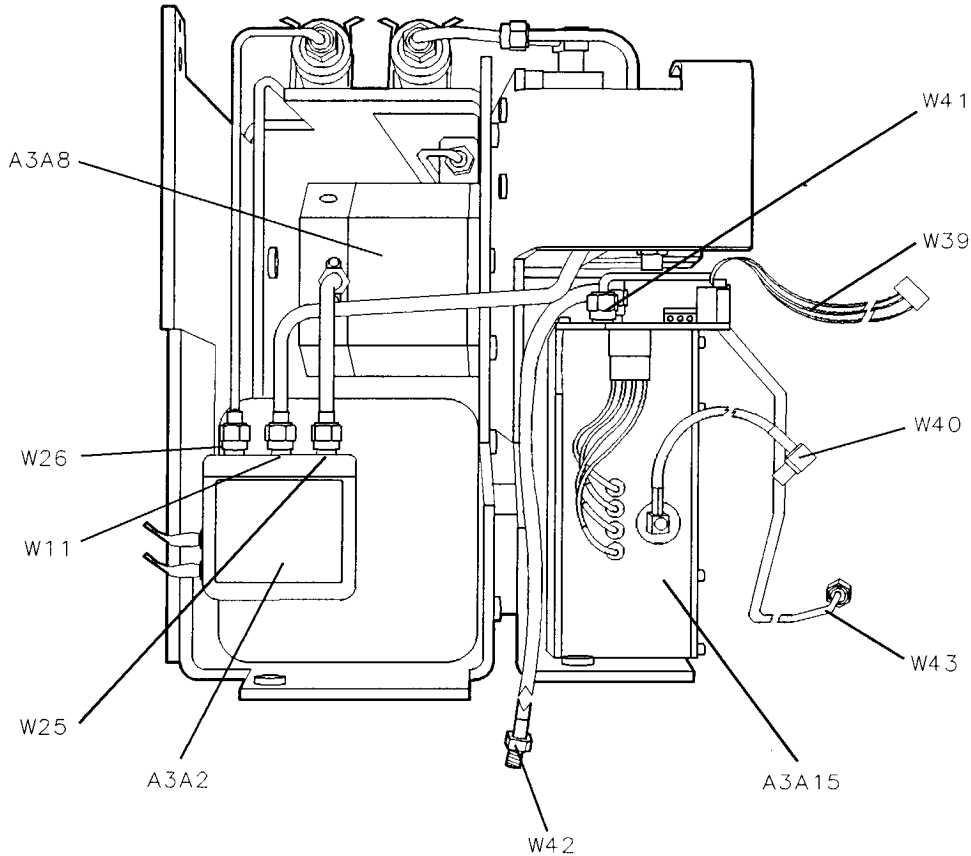
**Figure 11-28.**  
**A3 Front-End Assembly, Right-Side View**  
**HP 8594E (Options 009 and 010)**





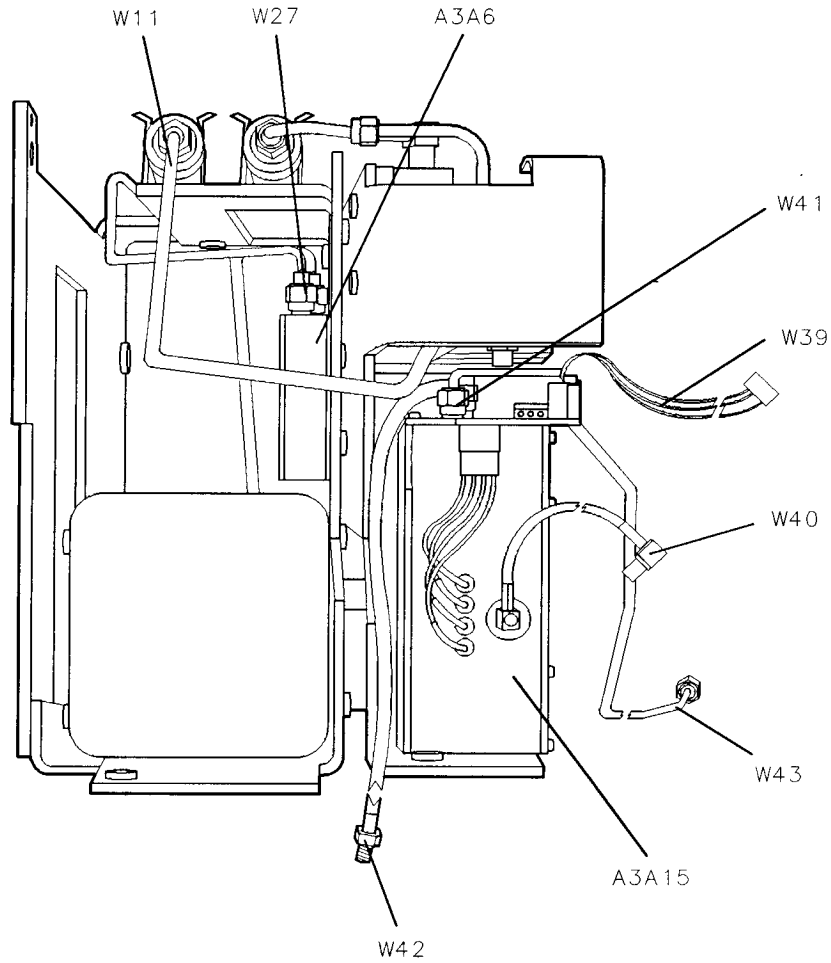
sh295e

**Figure 11-29.**  
**A3 Front-End Assembly, Right-Side View**  
**HP 8595E and HP 8596E (Options 009 and 010)**



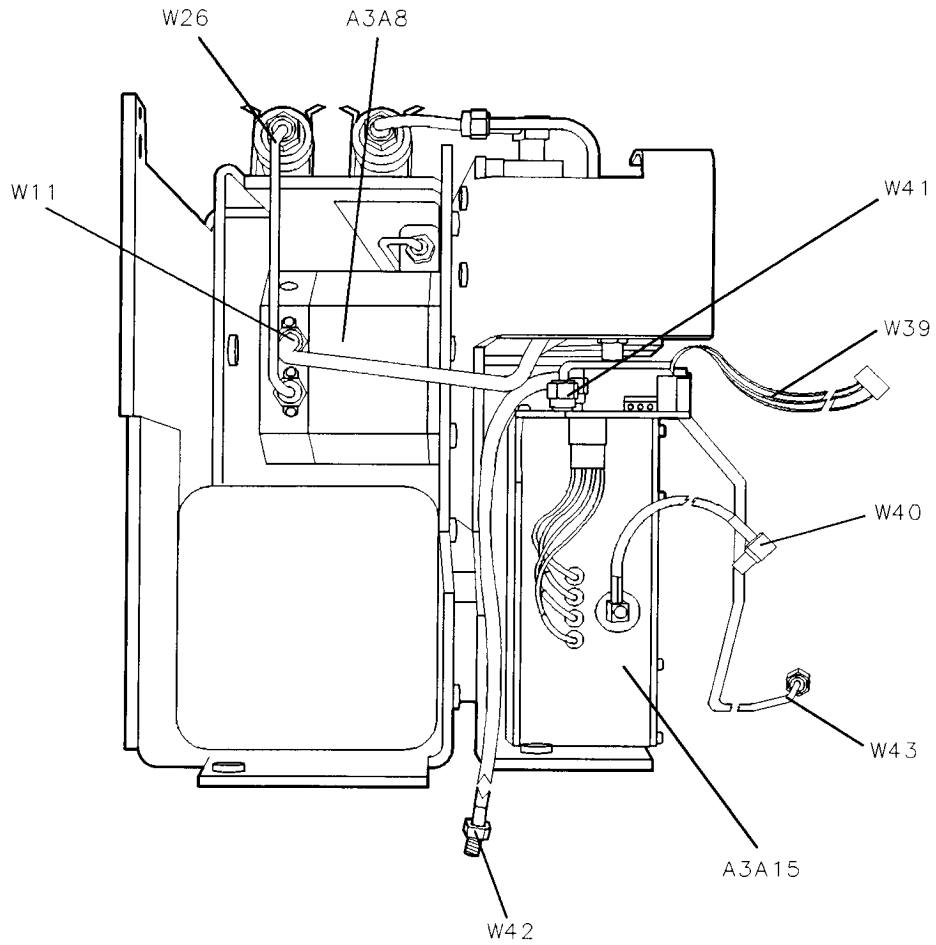
sh296e

**Figure 11-30.**  
**A3 Front-End Assembly, Rear View with A3A5 Removed**  
**HP 8593E (Options 009 and 010)**



sh297e

**Figure 11-31.**  
**A3 Front-End Assembly, Rear View with A3A5 Removed**  
**HP 8594E (Options 009 and 010)**



sh298e

**Figure 11-32.**  
**A3 Front-End Assembly,**  
**Rear View with A3A5 Removed**  
**HP 8595E and HP 8596E (Options 009 and 010)**

## Replaceable Parts

---

This chapter contains information for identifying and ordering replacement assemblies for the HP 8590 E-Series and L-Series spectrum analyzers, HP 8591C cable TV analyzers, and HP 8594Q QAM analyzers. Each assembly applies to all HP 8590 E-Series and L-Series spectrum analyzers, except where specified with the applicable analyzer models.

Major assembly and cable location information is given in Chapter 11.

The following tables and figures are also included in this chapter:

- Table 12-1 lists reference designations, abbreviations, and value multipliers used in the parts lists.
- Table 12-2 lists standard value replacement capacitors.
- Table 12-3 lists standard value replacement resistors, 0.125 W.
- Table 12-4 lists standard value replacement resistors, 0.5 W.
- Table 12-5 lists all major assemblies, and all major mechanical and electrical parts that are not part of a major assembly.
- Table 12-6 lists the cable assemblies.
- Table 12-7 lists available component-level information packets.
- Figures 12-1 through 12-8, and foldouts 12-1 through 12-7 give the analyzer parts identification information.

---

**Note**            The parts lists, schematics, and component-location diagrams for the HP 8590 E-Series and L-Series spectrum analyzers, HP 8591C cable TV analyzers, and HP 8594Q QAM analyzers board assemblies are available separately in the *HP 8590 Series Analyzers Component-Level Repair Service Guide*.

---

---

## Ordering Information

Parts can be ordered by addressing the order to the nearest Hewlett-Packard office. Customers within the USA can also use either the direct mail-order system, or the direct phone-order system described below. The direct phone-order system has a toll-free phone number available.

### **To order an assembly or mechanical part listed in this chapter:**

1. Determine the Hewlett-Packard part number.
2. Determine the quantity required.
3. Mail this information to the nearest Hewlett-Packard sales and service office. Refer to Chapter 8 for information about sales and service offices.

### **To order a part that is *not* listed in the replaceable parts lists:**

1. Note the instrument model number.
2. Note the instrument serial number and options, if any (see instrument rear panel).
3. Describe the part, its location, what it looks like, and its function (if known).
4. Determine the quantity needed.
5. Mail this information to the nearest Hewlett-Packard sales and service office. Refer to Chapter 8 for information about sales and service offices.

### **Direct Mail-Order System**

Within the USA, Hewlett-Packard can supply parts through a direct mail-order system. Advantages of using the system are as follows:

- Direct ordering and shipment from Hewlett-Packard.
- No maximum or minimum on any mail order. (There is a minimum order amount for parts ordered through a local HP office when the orders require billing and invoicing.)
- Prepaid transportation. (There is a small handling charge for each order.)
- No invoices.

To provide these advantages, a check or money order must accompany each order. Mail-order forms and specific ordering information are available through your local HP office.

## **Direct Phone-Order System using (800) 227-8164 (U.S. Only)**

Within the USA, a phone order system is available for regular and hotline replacement parts service. A toll-free phone number is available, and Mastercard and Visa are accepted.

### **Regular Orders**

The toll-free phone number, (800) 227-8164, is available Monday through Friday, 6 AM to 5 PM (Pacific time). Regular orders have a four-day delivery time.

### **Hotline Orders**

Hotline service is available 24 hours a day, 365 days a year, for emergency parts ordering. The toll-free phone number, (800) 227-8164, is available Monday through Friday, 6 AM to 5 PM (Pacific time).

To cover the cost of freight and special handling, there is an additional hotline charge on each order (three line items maximum per order). Hotline orders are normally delivered the next business day after they are ordered.

**Table 12-1.  
Reference Designations, Abbreviations and Multipliers (1 of 4)**

<b>REFERENCE DESIGNATIONS</b>		
A Assembly	F Fuse	RT Thermistor
AT Attenuator, Isolator, Limiter, Termination	FL Filter	S Switch
B Fan, Motor	HY Circulator	T Transformer
BT Battery	J Electrical Connector (Stationary Portion), Jack	TB Terminal Board
C Capacitor	K Relay	TC Thermocouple
CP Coupler	L Coil, Inductor	TP Test Point
CR Diode, Diode Thyristor, Step Recovery Diode, Varactor	M Meter	U Integrated Circuit, Microcircuit
DC Directional Coupler	MP Miscellaneous Mechanical Part	V Electron Tube
DL Delay Line	P Electrical Connector (Movable Portion), Plug	VR Breakdown Diode (Zener), Voltage Regulator
DS Annunciator, Lamp, Light Emitting Diode (LED), Signaling Device (Visible)	Q Silicon Controlled Rectifier (SCR), Transistor, Triode Thyristor	W Cable, Wire, Jumper
E Miscellaneous Electrical Part	R Resistor	X Socket
		Y Crystal Unit (Piezoelectric, Quartz)
		Z Tuned Cavity, Tuned Circuit

<b>ABBREVIATIONS</b>		
<b>A</b>	BSC Basic	CNDCT Conducting, Conductive, Conductivity, Conductor
A Across Flats, Acrylic, Air (Dry Method), Ampere	BTN Button	
ADJ Adjust, Adjustment	<b>C</b>	CONT Contact, Continuous, Control, Controller
ANSI American National Standards Institute (formerly USASI-ASA)	C Capacitance, Capacitor, Center Tapped, Cermet, Cold, Compression	CONV Converter
ASSY Assembly	CCP Carbon Composition Plastic	CPRSN Compression
AWG American Wire Gage	CD Cadmium, Card, Cord	CUP-PT Cup Point
<b>B</b>	CER Ceramic	CW Clockwise, Continuous Wave
BCD Binary Coded Decimal	CHAM Chamfer	
BD Board, Bundle	CHAR Character, Characteristic, Charcoal	<b>D</b>
BE-CU Beryllium Copper	CMOS Complementary Metal Oxide Semiconductor	D Deep, Depletion, Depth, Diameter, Direct Current
BNC Type of Connector		DA Darlington
BRG Bearing, Boring		
BRS Brass		



**Table 12-1.  
Reference Designations, Abbreviations, and Multipliers (2 of 4)**

<b>ABBREVIATIONS</b>					
DAP-GL	Diallyl Phthalate Glass	FT	Current Gain Bandwidth Product (Transition Frequency), Feet, Foot	JFET	Junction Field Effect Transistor
DBL	Double			<b>K</b>	
DCDR	Decoder				
DEG	Degree				
D-HOLE	D-Shaped Hole	FXD	Fixed	K	Kelvin, Key, Kilo, Potassium
DIA	Diameter				
DIP	Dual In-Line Package	<b>G</b>		KNRLD	Knurled
DIP-SLDR	Dip Solder			KVDC	Kilovolts Direct Current
D-MODE	Depletion Mode	GEN	General, Generator		
DO	Package Type Designation	GND	Ground		
DP	Deep, Depth, Dia- metric Pitch, Dip	GP	General Purpose, Group	<b>L</b>	
DP3T	Double Pole Three Throw			LED	Light Emitting Diode
DPDT	Double Pole Double Throw	<b>H</b>		LG	Length, Long
DWL	Dowell	H	Henry, High	LIN	Linear, Linearity
	<b>E</b>	HDW	Hardware	LK	Link, Lock
E-R	E-Ring	HEX	Hexadecimal, Hexagon, Hexagonal	LKG	Leakage, Locking
EXT	Extended, Extension, External, Extinguish	HLCL	Helical	LUM	Luminous
	<b>F</b>	HP	Hewlett-Packard Company, High Pass	<b>M</b>	
F	Fahrenheit, Farad, Female, Film (Resistor), Fixed, Flange, Frequency	<b>I</b>		M	Male, Maximum, Mega, Mil, Milli, Mode
FC	Carbon Film/ Composition, Edge of Cutoff Frequency, Face	IC	Collector Current, Integrated Circuit	MA	Milliampere
FDTHRU	Feedthrough	ID	Identification, Inside Diameter	MACH	Machined
FEM	Female	IF	Forward Current, Intermediate Frequency	MAX	Maximum
FIL-HD	Fillister Head	IN	Inch	MC	Molded Carbon Composition
FL	Flash, Flat, Fluid	INCL	Including	MET	Metal, Metallized
FLAT-PT	Flat Point	INT	Integral, Intensity, Internal	MHZ	Megahertz
FR	Front			MINTR	Miniature
FREQ	Frequency	<b>J</b>		MIT	Miter
		J-FET	Junction Field Effect Transistor	MLD	Mold, Molded
				MM	Magnetized Material, Millimeter
				MOM	Momentary
				MTG	Mounting
				MTLC	Metallic
				MW	Milliwatt

**Table 12-1.  
Reference Designations, Abbreviations, and Multipliers (3 of 4)**

<b>ABBREVIATIONS</b>			
<b>N</b>		PLSTC Plastic	SMA Subminiature, A Type (Threaded Connector)
N	Nano, None	PNL Panel	
N-CHAN	N-Channel	PNP Positive Negative Positive (Transistor)	SMB Subminiature, B Type (Slip-on Connector)
NH	Nanohenry	POLYC Polycarbonate	
NM	Nanometer, Nonmetallic	POLYE Polyester	SMC Subminiature, C-Type (Threaded Connector)
NO	Normally Open, Number	POT Potentiometer	
NOM	Nominal	POZI Pozidriv Recess	SPCG Spacing
NPN	Negative Positive Negative (Transistor)	PREC Precision	SPDT Single Pole Double Throw
NS	Nanosecond, Non-Shorting, Nose	PRP Purple, Purpose	SPST Single Pole Single Throw
NUM	Numeric	PSTN Piston	SQ Square
NYL	Nylon (Polyamide)	PT Part, Point, Pulse Time	SST Stainless Steel
		PW Pulse Width	STL Steel
			SUBMIN Subminiature
		<b>Q</b>	SZ Size
		Q Figure of Merit	
			<b>T</b>
OA	Over-All		T Teeth, Temperature, Thickness, Time, Timed, Tooth, Typical
OD	Outside Diameter	<b>R</b>	
OP AMP	Operational Amplifier	R Range, Red, Resistance, Resistor, Right, Ring	TA Ambient Temperature, Tantalum
OPT	Optical, Option, Optional	REF Reference	TC Temperature Coefficient
		RES Resistance, Resistor	THD Thread, Threaded
		RF Radio Frequency	THK Thick
PA	Picoampere, Power Amplifier	RGD Rigid	TO Package Type Designation
PAN-HD	Pan Head	RND Round	TPG Tapping
PAR	Parallel, Parity	RR Rear	TR-HD Truss Head
PB	Lead (Metal), Pushbutton	RVT Rivet, Riveted	TRMR Trimmer
PC	Printed Circuit		TRN Turn, Turns
PCB	Printed Circuit Board	<b>S</b>	TRSN Torsion
P-CHAN	P-Channel	SAWR Surface Acoustic Wave Resonator	
PD	Pad, Power Dissipation	SEG Segment	
PF	Picofarad, Power Factor	SGL Single	
PKG	Package	SI Silicon, Square Inch	
		SL Slide, Slow	
		SLT Slot, Slotted	

**Table 12-1.**  
**Reference Designations, Abbreviations, and Multipliers (4 of 4)**

<b>ABBREVIATIONS</b>					
	<b>U</b>		VAR Variable		<b>Y</b>
			VDC Volts—Direct Current		YIG Yttrium-Iron-Garnet
UCD	Microcandela				
UF	Microfarad				
UH	Microhenry		<b>W</b>		
UL	Microliter,				
	Underwriters'		W Watt, Wattage,		<b>Z</b>
	Laboratories, Inc.		White, Wide, Width		
UNHDND	Unhardened		W/SW With Switch		ZNR Zener
			WW Wire Wound		
	<b>V</b>				
			<b>X</b>		
V	Variable, Violet,				
	Volt, Voltage		X By (Used with		
VAC	Vacuum, Volts—		Dimensions),		
	Alternating Current		Reactance		

<b>MULTIPLIERS</b>					
<b>Abbreviation</b>	<b>Prefix</b>	<b>Multiple</b>	<b>Abbreviation</b>	<b>Prefix</b>	<b>Multiple</b>
T	tera	10 <sup>12</sup>	m	milli	10 <sup>-3</sup>
G	giga	10 <sup>9</sup>	μ	micro	10 <sup>-6</sup>
M	mega	10 <sup>6</sup>	n	nano	10 <sup>-9</sup>
k	kilo	10 <sup>3</sup>	p	pico	10 <sup>-12</sup>
da	deka	10	f	femto	10 <sup>-15</sup>
d	deci	10 <sup>-1</sup>	a	atto	10 <sup>-18</sup>
c	centi	10 <sup>-2</sup>			

# Standard-Value Replacement Components

**Table 12-2. Standard Value Replacement Capacitors**

Capacitors					
Type: Tubular Range: 1 to 24 pF Tolerance: 1 to 9.1 pF = $\pm 0.25$ pF 10 to 24 pF = $\pm 5\%$			Type: Dipped Mica Range: 27 to 470 pF Tolerance: $\pm 5\%$		
Value (pF)	HP Part Number	CD	Value (pF)	HP Part Number	CD
1.0	0160-2236	8	27	0160-2306	3
1.2	0160-2237	9	30	0160-2199	2
1.5	0150-0091	8	33	0160-2150	5
1.8	0160-2239	1	36	0160-2308	5
2.0	0160-2240	4	39	0140-0190	7
2.2	0160-2241	5	43	0160-2200	6
2.4	0160-2242	6	47	0160-2307	4
2.7	0160-2243	7	51	0160-2201	7
3.0	0160-2244	8	56	0140-0191	8
3.3	0150-0059	8	62	0140-0205	5
3.6	0160-2246	0	68	0140-0192	9
3.9	0160-2247	1	75	0160-2202	8
4.3	0160-2248	2	82	0140-0193	0
4.7	0160-2249	3	91	0160-2203	9
5.1	0160-2250	6	100	0160-2204	0
5.6	0160-2251	7	110	0140-0194	1
6.2	0160-2252	8	120	0160-2205	1
6.8	0160-2253	9	130	0140-0195	2
7.5	0160-2254	0	150	0140-0196	3
8.2	0160-2255	1	160	0160-2206	2
9.1	0160-2256	2	180	0140-0197	4
10.0	0160-2257	3	200	0140-0198	5
11.0	0160-2258	4	220	0160-0134	1
12.0	0160-2259	5	240	0140-0199	6
13.0	0160-2260	8	270	0140-0210	2
15.0	0160-2261	9	300	0160-2207	3
16.0	0160-2262	0	330	0160-2208	4
18.0	0160-2263	1	360	0160-2209	5
20.0	0160-2264	2	390	0140-0200	0
22.0	0160-2265	3	430	0160-0939	4
24.0	0160-2266	4	470	0160-3533	0

**Table 12-3. Standard Value Replacement Resistors, 0.125 W**

Resistors					
Type: Fixed-Film Range: 10 $\Omega$ to 464 K $\Omega$ Wattage: 0.125 at 125°C Tolerance: $\pm 1.0\%$					
Value ( $\Omega$ )	HP Part Number	CD	Value ( $\Omega$ )	HP Part Number	CD
10.0	0757-0346	2	422	0698-3447	4
11.0	0757-0378	0	464	0698-0082	7
12.1	0757-0379	1	511	0757-0416	7
13.3	0698-3427	0	562	0757-0417	8
14.7	0698-3428	1	619	0757-0418	9
16.2	0757-0382	6	681	0757-0419	0
17.8	0757-0294	9	750	0757-0420	3
19.6	0698-3429	2	825	0757-0421	4
21.5	0698-3430	5	909	0757-0422	5
23.7	0698-3431	6	1.0K	0757-0280	3
26.1	0698-3432	7	1.1K	0757-0424	7
28.7	0698-3433	8	1.21K	0757-0274	5
31.6	0757-0180	2	1.33K	0757-0317	7
34.8	0698-3434	9	1.47K	0757-1094	9
38.3	0698-3435	0	1.62K	0757-0428	1
42.2	0757-0316	6	1.78K	0757-0278	9
46.4	0698-4037	0	1.96K	0698-0083	8
51.1	0757-0394	0	2.15K	0698-0084	9
56.2	0757-0395	1	2.37K	0698-3150	6
61.9	0757-0276	7	2.61K	0698-0085	0
68.1	0757-0397	3	2.87K	0698-3151	7
75.0	0757-0398	4	3.16K	0757-0279	0
82.5	0757-0399	5	3.48K	0698-3152	8
90.9	0757-0400	9	3.83K	0698-3153	9
100	0757-0401	0	4.22K	0698-3154	0
110	0757-0402	1	4.64K	0698-3155	1
121	0757-0403	2	5.11K	0757-0438	3
133	0698-3437	2	5.62K	0757-0200	7
147	0698-3438	3	6.19K	0757-0290	5
162	0757-0405	4	6.81K	0757-0439	4
178	0698-3439	4	7.50K	0757-0440	7
196	0698-3440	7	8.25K	0757-0441	8
215	0698-3441	8	9.09K	0757-0288	1
237	0698-3442	9	10.0K	0757-0442	9
261	0698-3132	4	11.0K	0757-0443	0
287	0698-3443	0	12.1K	0757-0444	1
316	0698-3444	1	13.3K	0757-0289	2
348	0698-3445	2	14.7K	0698-3156	2
383	0698-3446	3	16.2K	0757-0447	4

**Table 12-3. Standard Value Replacement Resistors, 0.125 W (continued)**

Resistors					
Type: Fixed-Film					
Range: 10 $\Omega$ to 464 K $\Omega$					
Wattage: 0.125 at 125°C					
Tolerance: $\pm 1.0\%$					
Value ( $\Omega$ )	HP Part Number	CD	Value ( $\Omega$ )	HP Part Number	CD
17.8K	0698-3136	8	100K	0757-0465	6
19.6K	0698-3157	3	110K	0757-0466	7
21.5K	0757-0199	3	121K	0757-0467	8
23.7K	0698-3158	4	133K	0698-3451	0
26.1K	0698-3159	5	147K	0698-3452	1
28.7K	0698-3449	6	162K	0757-0470	3
31.6K	0698-3160	8	178K	0698-3243	8
34.8K	0757-0123	3	196K	0698-3453	2
38.3K	0698-3161	9	215K	0698-3454	3
42.2K	0698-3450	9	237K	0698-3266	5
46.4K	0698-3162	0	261K	0698-3455	4
51.1K	0757-0458	7	287K	0698-3456	5
56.2K	0757-0459	8	316K	0698-3457	6
61.9K	0757-0460	1	348K	0698-3458	7
68.1K	0757-0461	2	383K	0698-3459	8
75.0K	0757-0462	3	422K	0698-3460	1
82.5K	0757-0463	4	464K	0698-3260	9
90.9K	0757-0464	5			

**Table 12-4. Standard Value Replacement Resistors, 0.5 W**

Resistors					
Type: Fixed-Film					
Range: 10 $\Omega$ to 1.47 M $\Omega$					
Wattage: 0.5 at 125°C					
Tolerance: $\pm 1.0\%$					
Value ( $\Omega$ )	HP Part Number	CD	Value ( $\Omega$ )	HP Part Number	CD
10.0	0757-0984	4	383	0698-3404	3
11.0	0575-0985	5	422	0698-3405	4
12.1	0757-0986	6	464	0698-0090	7
13.3	0757-0001	6	511	0757-0814	9
14.7	0698-3388	2	562	0757-0815	0
16.2	0757-0989	9	619	0757-0158	4
17.8	0698-3389	3	681	0757-0816	1
19.6	0698-3390	6	750	0757-0817	2
21.5	0698-3391	7	825	0757-0818	3
23.7	0698-3392	8	909	0757-0819	4
26.1	0757-0003	8	1.00K	0757-0159	5
28.7	0698-3393	9	1.10K	0757-0820	7
31.6	0698-3394	0	1.21K	0757-0821	8
34.8	0698-3395	1	1.33K	0698-3406	5
38.3	0698-3396	2	1.47K	0757-1078	9
42.2	0698-3397	3	1.62K	0757-0873	0
46.4	0698-3398	4	1.78K	0698-0089	4
51.1	0757-1000	7	1.96K	0698-3407	6
56.2	0757-1001	8	2.15K	0698-3408	7
61.9	0757-1002	9	2.37K	0698-3409	8
68.1	0757-0794	4	2.61K	0698-0024	7
75.0	0757-0795	5	2.87K	0698-3101	7
82.5	0757-0796	6	3.16K	0698-3410	1
90.0	0757-0797	7	3.48K	0698-3411	2
100	0757-0198	2	3.83K	0698-3412	3
110	0757-0798	8	4.22K	0698-3346	2
121	0757-0799	9	4.64K	0698-3348	4
133	0698-3399	5	5.11K	0757-0833	2
147	0698-3400	9	5.62K	0757-0834	3
162	0757-0802	5	6.19K	0757-0196	0
178	0698-3334	8	6.81K	0757-0835	4
196	0757-1060	9	7.50K	0757-0836	5
215	0698-3401	0	8.25K	0757-0837	6
237	0698-3102	8	9.09K	0757-0838	7
261	0757-1090	5	10.0K	0757-0839	8
287	0757-1092	7	12.1K	0757-0841	2
316	0698-3402	1	13.3K	0698-3413	4
348	0698-3403	2	14.7K	0698-3414	5

**Table 12-4. Standard Value Replacement Resistors, 0.5 W (continued)**

Resistors					
Type: Fixed-Film					
Range: 10 $\Omega$ to 1.47 M $\Omega$					
Wattage: 0.5 at 125°C					
Tolerance: $\pm$ 1.0%					
Value ( $\Omega$ )	HP Part Number	CD	Value ( $\Omega$ )	HP Part Number	CD
16.2K	0757-0844	5	162K	0757-0130	2
17.8K	0698-0025	8	178K	0757-0129	9
19.6K	0698-3415	6	196K	0757-0063	0
21.5K	0698-3416	7	215K	0757-0127	7
23.7K	0698-3417	8	237K	0698-3424	7
26.1K	0698-3418	9	261K	0757-0064	1
28.7K	0698-3103	9	287K	0757-0154	0
31.6K	0698-3419	0	316K	0698-3425	8
34.8K	0698-3420	3	348K	0757-0195	9
38.3K	0698-3421	4	383K	0757-0133	5
42.2K	0698-3422	5	422K	0757-0134	6
46.4K	0698-3423	6	464K	0698-3426	9
51.1K	0757-0853	6	511K	0757-0135	7
56.2K	0757-0854	7	562K	0757-0868	3
61.9K	0757-0309	7	619K	0757-0136	8
68.1K	0757-0855	8	681K	0757-0869	4
75.0K	0757-0856	9	750K	0757-0137	9
82.5K	0757-0857	0	825K	0757-0870	7
90.9K	0757-0858	1	909K	0757-0138	0
100K	0757-0367	7	1M	0757-0059	4
110K	0757-0859	2	1.1M	0757-0139	1
121K	0757-0860	5	1.21M	0757-0871	8
133K	0757-0310	0	1.33M	0757-0194	8
147K	0698-3175	5	1.47M	0698-3464	5



**Table 12-5. Assembly-Level Replaceable Parts**

Reference Designator	Description	CD	HP Part Number
A1A1	<b>Keyboard</b> All HP 8590 E-Series and L-Series spectrum analyzers, HP 8591C cable TV analyzers, and HP 8594Q QAM analyzers	4	08590-60201
A1A2	<b>Rotary Pulse Generator</b> All HP 8590 E-Series and L-Series spectrum analyzers, HP 8591C cable TV analyzers, and HP 8594Q QAM analyzers  Old Style  New Style	5	0960-0745  1990-1525
A1R1	<b>Volume-Intensity Dual Pot Assembly</b> All HP 8590 E-Series spectrum analyzers, HP 8591C cable TV analyzers, and HP 8594Q QAM analyzers  All HP 8590 L-Series spectrum analyzers	1	08590-60133  08590-60041
A2	<b>Display</b> All HP 8590 E-Series and L-Series spectrum analyzers, HP 8591C cable TV analyzers, and HP 8594Q QAM analyzers	7	08590-60377
A3	<b>Input Attenuator</b> HP 8590L and HP 8591E  HP 8591C  <b>Front End (Includes A3A1 through A3A15)</b> HP 8592L, HP 8593E, HP 8594E, HP 8594L, HP 8594Q, HP 8595E, and HP 8596E	2  2	0955-0453  0955-0700  See A3A5
A3A1	<b>Comb Generator</b> HP 8592L, HP 8593E, and HP 8596E	9	08592-60098
A3A1A1	<b>Comb Generator Board (part of A3A1)</b> HP 8592L, HP 8593E, and HP 8596E	4	08569-60026
A3A2	<b>Microwave Switch</b> HP 8592L and HP 8593E  HP 8592L and HP 8593E, (Option 026 and Option 027)	3  4	33314-60011  33314-60012
A3A3	<b>Low-Pass Filter</b> HP 8592L, HP 8593E, HP 8594E, HP 8594L, HP 8594Q, HP 8595E, and HP 8596E	3	0955-0420
A3A4	<b>Second Converter</b> HP 8592L, HP 8593E, HP 8594E, HP 8594L, HP 8594Q, HP 8595E, and HP 8596E		5086-7958
A3A5	<b>Input Attenuator</b> HP 8592L and HP 8593E  HP 8592L and HP 8593E, (Options 026 and 027)  HP 8594E, HP 8594L, HP 8594Q, and HP 8595E  HP 8596E	4  3  1  2	33321-60039  33321-60038  33321-60036  33321-60037

**Table 12-5. Assembly-Level Replaceable Parts (continued)**

Reference Designator	Description	CD	HP Part Number
A3A6	<b>Dual Mixer</b> HP 8592L, HP 8593E, HP 8595E, and HP 8596E	2	5086-7952
	<b>Low Band Mixer</b> HP 8594E, HP 8594L, and HP 8594Q		5086-7748
A3A7	<b>Yig-Tuned Oscillator (YTO)</b> HP 8592L, HP 8593E, HP 8594E, HP 8594L, HP 8594Q, HP 8595E, and HP 8596E	3	5086-7903
A3A8	<b>Yig-Tuned Filter (YTF)</b> HP 8592L and HP 8593E	8	0955-0277
	HP 8592L and HP 8593E, (Options 026 and 027)	9	5086-7850
	<b>Switched Yig-Tuned Filter (SYTF)</b> HP 8595E	2	5086-7803
	HP 8596E	5	5086-7880
A3A9	<b>Bandpass Filter Assembly</b> HP 8592L, HP 8593E, HP 8594E, HP 8594L, HP 8594Q, HP 8595E, and HP 8596E	0	9135-0252
A3A10	<b>Directional Coupler</b> HP 8593E, HP 8594E, HP 8594L, HP 8595E, and HP 8596E	1	0955-0098
A3A11	<b>Step Recovery Diode</b> HP 8592L, HP 8593E, and HP 8596E	3	0955-0149
A3A12	<b>3 dB Attenuator</b> HP 8592L, HP 8593E, and HP 8596E	3	0955-0412
A3A13	<b>Isolator</b> HP 8592L, HP 8593E, HP 8594E, HP 8594L, HP 8594Q, HP 8595E, and HP 8596E	1	0955-0204
A3A14	<b>LO Distribution Amplifier (LODA)</b> HP 8593E, HP 8594E, HP 8595E, and HP 8596E	0	5086-7744
A3A15	<b>Tracking Generator</b> HP 8593E, HP 8594E, HP 8595E, and HP 8596E	5	5086-7917
	<b>Tracking Generator Exchange</b> HP 8593E, HP 8594E, HP 8595E, and HP 8596E		3

**Table 12-5. Assembly-Level Replaceable Parts (continued)**

Reference Designator	Description	CD	HP Part Number
<b>A3A16</b>	<b>Output Attenuator</b> HP 8593E, HP 8594E, HP 8594Q, HP 8595E, and HP 8596E	0	0955-0679
<b>A3A17</b>	<b>Preamp Control</b> HP 8594Q (Option 190)		0955-1024
<b>A3A18</b>	<b>Coax Switch</b> HP 8594Q (Option 190)		33312-60006
<b>A4</b>	<b>First Converter</b> HP 8590L, HP 8591C, and HP 8591E	9	08590-60214
<b>A5</b>	<b>Second Converter</b> HP 8590L, HP 8591C, and HP 8591E	1	08590-60117
<b>A5A1</b>	<b>Tripler</b> HP 8590L, HP 8591C, and HP 8591E		08590-60155
<b>A6</b>	<b>Yig-Tuned Oscillator (YTO), 2-4 GHz</b> HP 8590L HP 8591C and HP 8591E		0955-0974 0955-0974
<b>A6A1</b>	<b>YIG Board</b> HP 8590L, HP 8591C, and HP 8591E	7	5062-4888
<b>A7</b>	<b>Analog Interface</b> HP 8590L and HP 8591E HP 8591C HP 8592L and HP 8593E HP 8594E, HP 8594L, and HP 8594Q HP 8595E and HP 8596E	7 8  1 2	08590-60197 08591-60072 08592-60108 08594-60030 08595-60022
<b>A7A1</b>	<b>Tracking Generator Control</b> HP 8590L, HP 8591C, and HP 8591E	6	08590-60196
<b>A8</b>	<b>Power Supply</b> All HP 8590 E-Series and L-Series spectrum analyzers, HP 8591C cable TV analyzers, and HP 8594Q QAM analyzers  <b>Power Supply Exchange</b> All HP 8590 E-Series and L-Series spectrum analyzers and HP 8591C cable TV analyzers	8	5062-8229  08590-69005

**Table 12-5. Assembly-Level Replaceable Parts (continued)**

<b>Reference Designator</b>	<b>Description</b>	<b>CD</b>	<b>HP Part Number</b>
<b>A9</b>	<b>Third Converter</b> HP 8590L and HP 8591E (50 $\Omega$ input)	9	08591-60081
	HP 8590L, HP 8591C, and HP 8591E (75 $\Omega$ input)	6	08590-60344
	All HP 8590 E-Series and HP 8592L spectrum analyzers, and HP 8594Q QAM analyzers	8	08593-60062
<b>A10</b>	<b>LO Distribution Amplifier (LODA) Control for Option 009</b> HP 8593E, HP 8594E, HP 8595E, and HP 8596E	3	5062-8232
	<b>Tracking Generator Control for Option 010</b> HP 8593E, HP 8594E, HP 8595E, and HP 8596E	5	5063-0635
<b>A11</b>	<b>Bandwidth Board</b> All HP 8590 E-Series and L-Series spectrum analyzers, HP 8591C cable TV analyzers, and HP 8594Q QAM analyzers		08590-60398
<b>A12</b>	<b>Amplitude Control Board</b> All HP 8590 E-Series and L-Series spectrum analyzers, HP 8591C cable TV analyzers, and HP 8594Q QAM analyzers	7	08590-60105
<b>A13</b>	<b>Bandwidth Board</b> All HP 8590 E-Series and L-Series spectrum analyzers, HP 8591C cable TV analyzers, and HP 8594Q QAM analyzers		08590-60398
<b>A14</b>	<b>Log Amplifier Board</b> All HP 8590 E-Series and L-Series spectrum analyzers, HP 8591C cable TV analyzers, and HP 8594Q QAM analyzers		08590-60386
<b>A15</b>	<b>Motherboard</b> HP 8590L, HP 8592L, and HP 8594L	3	08590-60218
	HP 8591C, HP 8591E, HP 8593E, HP 8594E, HP 8594Q, HP 8595E, and HP 8596E	6	08591-60062
<b>A16</b>	<b>Processor Board</b> All HP 8590 E-Series and L-Series spectrum analyzers and HP 8591C cable TV analyzers	4	08590-60365
	HP 8594Q		08594-60054
<b>A16A1</b>	<b>2X Memory Board</b> All HP 8590 E-Series and L-Series spectrum analyzers, HP 8591C cable TV analyzer, and HP 8594Q QAM analyzers		08590-60399
<b>A16A1BT1</b>	<b>Battery</b> All HP 8590 E-Series and L-Series spectrum analyzers, HP 8591C cable TV analyzer, and HP 8594Q QAM analyzers		1420-0394
<b>A17</b>	<b>Memory Card</b> All HP 8590 E-Series and L-Series spectrum analyzers, HP 8591C cable TV analyzers, and HP 8594Q QAM analyzers	9	08590-60396

**Table 12-5. Assembly-Level Replaceable Parts (continued)**

Reference Designator	Description	CD	HP Part Number
A22	<b>10 MHz Reference</b> All HP 8590 E-Series and L-Series spectrum analyzers, HP 8591C cable TV analyzers and HP 8594Q QAM analyzers equipped with Option 704	8	08591-60048
	<b>10 MHz Precision Frequency Reference</b> HP 8591E, HP 8593E, HP 8594E, HP 8594Q, HP 8595E and HP 8596E (Option 004), HP 8591C, and HP 8594Q	4	1813-0644
A24	<b>Tracking Generator RF</b> <i>(Includes A24A1 through A24FL1)</i> HP 8590L, HP 8591C, and HP 8591E		N/A
A24A1	<b>Tripler</b> HP 8590L, HP 8591C, and HP 8591E	6	5086-7807
A24A2	<b>Tracking Converter</b> HP 8590L, HP 8591C, and HP 8591E	6	08590-60146
A24A3	<b>Amplifier/Detector</b> HP 8590L, HP 8591C, and HP 8591E	7	5086-7808
A24A4	<b>Output Attenuator</b> HP 8591C and HP 8591E	2	0955-0453
A24FL1	<b>Low-Pass Filter</b> HP 8590L, HP 8591C, and HP 8591E	8	0955-0491
A25	<b>Counter Lock Board</b> HP 8590L, HP 8591C, HP 8591E, HP 8592L, HP 8593E, HP 8595E, and HP 8596E		08591-60098
	HP 8594E, HP 8594L and HP 8594Q		08594-60083
A25A1	<b>Sampler Assembly</b> HP 8590L, HP 8591C, HP 8591E, HP 8592L, HP 8593E, HP 8595E, and HP 8596E		5086-7806
	HP 8594E, HP 8594L, and HP 8594Q		5086-7956
A26	<b>Preamp Assembly</b> HP 8594Q		08594-60067
A40	<b>HP-IB and Parallel Interface Board</b> All HP 8590 E-Series and L-Series spectrum analyzers, HP 8591C cable TV analyzers and HP 8594Q QAM analyzers equipped with Option 041	0	08590-60366
A40A1	<b>HP-IB and Parallel Interface Connector</b> All HP 8590 E-Series and L-Series spectrum analyzers and HP 8591C cable TV analyzers and HP 8594Q QAM analyzers (Option 041)	0	08590-60368
A41	<b>RS-232 and Parallel Interface Board</b> All HP 8590 E-Series and L-Series spectrum analyzers and HP 8591C cable TV analyzers and HP 8594Q QAM analyzers (Option 043)		08590-60366

**Table 12-5. Assembly-Level Replaceable Parts (continued)**

Reference Designator	Description	CD	HP Part Number
A41A1	<b>RS-232 and Parallel Interface Connector</b> All HP 8590 E-Series and L-Series spectrum analyzers and HP 8591C cable TV analyzers and HP 8594Q QAM analyzers (Option 043)	1	08590-60369
A41/A43	<b>Dual I/O Board</b> HP 8591C, HP 8591E, HP 8593E, HP 8594E, HP 8594L, HP 8594Q, HP 8595E, and HP 8596E (Option 041 or Option 043)		08590-60366
A101	<b>Fast ADC Board</b> HP 8591C, or HP 8591E, HP 8593E, HP 8594E, HP 8595E, and HP 8596E (Option 101)	4	5062-7079
A102	<b>Demod/TV-Sync Board</b> HP 8591C, or HP 8591E, HP 8593E, HP 8594E, HP 8595E, and HP 8596E (Option 102)	6	5062-1982
A103	<b>Demod/QPD Board</b> HP 8591E, HP 8593E, HP 8594E, HP 8595E, and HP 8596E (Option 103)	7	5062-1983
A105	<b>Gated Video Board</b> HP 8591C, or HP 8591E, HP 8593E, HP 8594E, HP 8595E, and HP 8596E (Option 105)	2	5062-7754
A110	<b>CELLULAR DEMOD/TV</b> HP 8591E, HP 8593E, HP 8594E, HP 8595E, and HP 8596E (Option 110)	1	5063-0234
A111	<b>Event Control Board</b> HP 8593E (Options E02, E04)	7	5063-0214
A119	<b>Noise Card Board</b> HP 8591C, HP 8591E, HP 8593E, HP 8594E, HP 8595E, and HP 8596E (Option 119)	3	5062-8258
A130	<b>Narrow Bandwidth Board</b> HP 8591C, HP 8591E, HP 8593E, HP 8594E, HP 8595E, and HP 8596E (Option 130)	7	08590-60352
A151	<b>Down Converter Assembly</b> HP 8591E, HP 8593E, HP 8594E, HP 8595E, and HP 8596E (Option 151)		5062-8246
A160	<b>DSP Assembly</b> HP 8591E, HP 8593E, HP 8594E, HP 8595E, and HP 8596E (Option 160) without firmware HP 8591E, HP 8593E, HP 8594E, HP 8595E, and HP 8596E (Option 160) with firmware		5062-8245 08591-60101
A163	<b>DSP Assembly (GSM/DCS Formats)</b> HP 8591E, HP 8593E, HP 8594E, HP 8595E, and HP 8596E (Option 163) with firmware		5062-0577
A190A1	<b>Downconverter (RF) Assembly</b> HP 8594Q (Option 190)		08594-60052

**Table 12-5. Assembly-Level Replaceable Parts (continued)**

Reference Designator	Description	CD	HP Part Number
A190A2	<b>Demod Assembly</b> HP 8594Q (Option 190)		08594-60084
A190A3	<b>DSP</b> HP 8594Q (Option 190)		08594-60051
AT1	<b>Isolator (2 to 4 GHz)</b> HP 8591C only <b>10 dB Attenuator</b> HP 8592L, HP 8593E, HP 8594E, HP 8594L, HP 8594Q, HP 8595E, HP 8596E, and HP 8591C		0960-0084 0955-0122
AT2	<b>50 Ohm Termination</b> HP 8590L and HP 8591E HP 8593E, HP 8594E, HP 8595E, and HP 8596E	9 3	0960-0053 1250-2289
B1	<b>Fan (includes cable assembly)</b> All HP 8590 E-Series and L-Series spectrum analyzers, HP 8591C cable TV analyzers, and HP 8594Q QAM analyzers	2	5063-0243
F1	<b>Fuse 5.0 A 250 V F</b> All HP 8590 E-Series and L-Series spectrum analyzers, HP 8591C cable TV analyzers, and HP 8594Q QAM analyzers	3	2110-0709
FL1	<b>Low-Pass Filter 4.4 GHz</b> HP 8592L, HP 8593E, HP 8594E, HP 8594L, HP 8594Q, HP 8595E, and HP 8596E <b>Low-Pass Filter 4.9 GHz</b> HP 8590L, HP 8591C, and HP 8591E	1 2	0955-0519 9135-0048
J1	<b>Input 50 <math>\Omega</math></b> HP 8590L, HP 8591E, HP 8594E, HP 8594L, and HP 8594Q HP 8592L, HP 8593E, HP 8595E, and HP 8596E HP 8592L and HP 8593E Option 026 HP 8592L and HP 8593E Option 027 <b>Input 75 <math>\Omega</math> (MLA)</b> HP 8591C HP 8590L, and HP 8591E (Option 001)	6	1250-2191 1250-2180 08673-60040 5063-0230 0955-1005 0955-1005
J3	<b>RF OUT 50 <math>\Omega</math></b> HP 8590L and HP 8591E Option 010 HP 8593E, HP 8594E, HP 8594Q, HP 8595E, and HP 8596E Option 010 <b>TG-RF OUT 50 <math>\Omega</math></b> HP 8593E Option 026 <b>RF OUT 75 <math>\Omega</math> (MLA)</b> HP 8590L, HP 8591C, and HP 8591E Option 011		1250-2191 1250-2191 5061-5311 0955-1005

**Table 12-6. Replaceable Cables**

Reference Designator	Description	CD	HP Part Number
W1	<b>CABLE ASSY WITH LINE SWITCH, A1 TO A16J9</b>		
	All HP 8590 Series analyzers	2	5062-4809
W2	<b>CABLE ASSY, DISPLAY VIDEO, A2 TO A16J8</b>		
	All HP 8590 -Series analyzers	7	5063-0602
W3	<b>CABLE ASSY, INTENSITY, WITHOUT POTENTIOMETER, A1R1 TO A2</b>		
	All HP 8590 Series analyzers	4	08590-60037
W4	<b>CABLE ASSY, KEYBOARD, A1A1J1 TO A16J10</b>		
	All HP 8590 Series analyzers	6	08592-60037
W5	<b>CABLE ASSY, PROBE POWER, WITH FILTER, WITHOUT CONNECTOR, A1A1 TO A1</b>		
	All HP 8590 Series analyzers	3	8120-8152
W6	<b>JUMPER, 10 MHz REF OUTPUT TO EXT REF IN</b>		
	All HP 8590 Series analyzers	5	1250-1499
W7	<b>CABLE ASSY, CAL OUTPUT, A9J2 TO A1</b>		
	HP 8590L, HP 8591C, and HP 8591E (75 Ω)	3	08590-60028
	HP 8590L, HP 8592L, HP 8591E, HP 8593E, HP 8594E, HP 8594L, HP 8594Q, HP 8595E, and HP 8596E (50 Ω)	6	8120-5052
W8	<b>CABLE ASSY, 600 MHz DRVR, A9J5 TO A3A4J4</b>		
	HP 8592L, HP 8593E, HP 8594E, HP 8594Q, HP 8595E, and HP 8596E	8	8120-5020
	<b>CABLE ASSY, 600 MHz DRVR, A9J5 TO A5J5</b>		
	HP 8590L, HP 8591C, and HP 8591E	8	8120-5020
W9	<b>CABLE ASSY, 2ND IF, A5J2 TO A9J4</b>		
	HP 8590L, HP 8591C, and HP 8591E	1	8120-5023
	<b>CABLE ASSY, 2ND IF, A3A9J2 TO A9J4</b>		
	HP 8592L, HP 8593E, HP 8594E, HP 8594L, HP 8594Q, HP 8595E, and HP 8596E	1	8120-5106
W10	<b>CABLE ASSY, RF INPUT, J1 TO A3</b>		
	HP 8590L and HP 8591E	5	08590-20157
	HP 8590L and HP 8591E (75 Ω input)	6	08590-20182
	HP 8591C	6	08591-20058
	<b>CABLE ASSY, RF INPUT, J1 TO A3A5J1</b>		
	HP 8592L, HP 8593E, HP 8594E, HP 8594L, HP 8594Q, HP 8595E, and HP 8596E	5	08592-20056
	HP 8592L and HP 8593E (OPTION 027)	5	08593-20013
HP 8592L and HP 8593E (OPTION 026)	1	08593-20001	



**Table 12-6. Replaceable Cables (continued)**

Reference Designator	Description	CD	HP Part Number
W11	<b>CABLE ASSY, ATTENUATOR OUTPUT, A3 TO A4J1</b>		
	HP 8590L and HP 8591E		08590-20110
	HP 8591C	5	08591-20057
	<b>CABLE ASSY, ATTENUATOR OUTPUT, A3A5J2 TO A3A2J1</b>		
	HP 8592L and HP 8593E	7	08592-20066
	HP 8594E, HP 8594L, and HP 8594Q	3	08594-20002
	HP 8595E, and HP 8596E	4	08595-20002
W12	<b>CABLE ASSY, YTO DRIVER, A7J3 TO A3A7</b>		
	HP 8590L, HP 8591C, and HP 8591E	2	08590-60035
	<b>CABLE ASSY, YTO DRIVER, A7J3 TO A3A7</b>		
	HP 8592L, HP 8593E, HP 8594E, HP 8594L, HP 8594Q, HP 8595E, and HP 8596E	4	08592-60019
W13	<b>CABLE ASSY, POWER CONTROL, A7J2 TO A3/A5</b>		
	HP 8590L and HP 8591E	6	08590-60138
	HP 8591C	3	8120-6338
	<b>CABLE ASSY, POWER CONTROL, A7J2 TO A3A1/A3A2/A3A6</b>		
	HP 8592L and HP 8593E	2	8120-5561
	HP 8595E	7	5063-0206
	HP 8596E	2	5062-7787
W14	<b>CABLE ASSY, COUNTER LOCK/MEMORY CARD CONTROL, A16J2 TO A17J1/A25J4</b>		
	All HP 8590 Series analyzers except HP 8590L with Option 713	0	8120-5535
W15	<b>CABLE ASSY, PRECISION FREQUENCY REFERENCE POWER, A25J3 TO A22</b>		
	All HP 8590 E-Series and L-Series spectrum analyzers, and HP 8594Q QAM analyzers	5	5063-0204
	HP 8591C, HP 8594Q, or HP 8590 Series analyzers (Option 004)	6	5063-0205
W17	<b>CABLE ASSY, 10 MHz OUTPUT, A22J1 TO REAR PANEL</b>		
	HP 8590 E-Series and L-Series spectrum analyzers and HP 8591C	7	08591-60013
W18	<b>CABLE ASSY, EXT REF IN</b>		
	HP 8590 E-Series and L-Series spectrum analyzers and HP 8591C	3	08591-60009
W19	<b>CABLE ASSY, COUNT IF, A25J5 TO A15J8</b>		
	HP 8590 E-Series and L-Series spectrum analyzers, and HP 8594Q QAM analyzers	6	08591-60012
W20	<b>CABLE ASSY, SAMPLER LO DRIVE A3A10 TO AT1</b>		
	HP 8592L, HP 8593E, HP 8594E, HP 8594L, HP 8594Q, HP 8595E, and HP 8596E	5	8120-5068
W21	<b>CABLE ASSY, 300 MHz COUNT LOCK DRIVE, A9J3 TO A25J1</b>		
	HP 8590L, HP 8591C, HP 8591E, HP 8592L, HP 8593E, HP 8595E, and HP 8596E	4	08591-60010

**Table 12-6. Replaceable Cables (continued)**

Reference Designator	Description	CD	HP Part Number
W22	<b>CABLE ASSY, FIRST CONVERTER OUTPUT, A4J3 TO FL1</b> HP 8590L and HP 8591E	2	08590-20203
	HP 8591C	2	08590-20112
	<b>CABLE ASSY, FIRST MIXER HI BAND, A3A6J5 TO A3A4J3</b> HP 8592L, HP 8593E, HP 8595E, and HP 8596E	3	8120-5067
W23	<b>CABLE ASSY, LPF TO SECOND CONVERTER, FL1 TO A5J1</b> HP 8590L and HP 8591E	3	08590-20204
	<b>CABLE ASSY, AT1 TO SECOND CONVERTER, AT1 TO A5J1</b> HP 8591C		08590-20113
	<b>CABLE ASSY, 2ND CONV. 321.4 MHz OUT, A3A4J2 TO A3A9J1</b> HP 8592L, HP 8593E, HP 8594E, HP 8594L, HP 8594Q, HP 8595E, and HP 8596E	2	8120-5058
W24	<b>CABLE ASSY, YTO OUTPUT, A6 TO A4J2</b> HP 8590L, HP 8591C, and HP 8591E	1	08590-20111
	<b>CABLE ASSY, COMB GENERATOR OUTPUT, A3A1J1 TO A3A11</b> HP 8592L, HP 8593E, HP 8596E	1	08592-60058
W25	<b>CABLE ASSY, 707 MHz, A7A1J6 TO A24A1J1</b> HP 8590L and HP 8591E	9	08590-60131
	<b>CABLE ASSY, YTF INPUT, A3A2 TO A3A8J1</b> HP 8592L and HP 8593E	9	08592-20068
	HP 8592L and HP 8593E (Options 026 and 027)	0	08592-20069
W26	<b>CABLE ASSY, TG TRIPLER OUTPUT, A24A1J2 TO A24A2J1</b> HP 8590L, HP 8591C, and HP 8591E	4	08590-20180
	<b>CABLE ASSY, 2.9 GHZ LPF IN, A3A2 TO A3A3J1</b> HP 8592L and HP 8593E	8	08592-20067
	HP 8595E and HP 8596E	5	08595-20003
W27	<b>CABLE ASSY, TG LO INPUT, A4J5 TO A24A2J2</b> HP 8590L and HP 8591E (Option 010)	9	08590-20177
	<b>CABLE ASSY, 2.9 GHZ LPF OUT, A3A3J2 TO A3A6J</b> HP 8592L, HP 8593E, HP 8595E, and HP 8596E	5	08592-20048
	HP 8593E, HP 8595E, and HP 8596E (Option 010)	2	08593-20010
	HP 8594E, HP 8594L, and HP 8594Q	4	08594-20003

**Table 12-6. Replaceable Cables (continued)**

Reference Designator	Description	CD	HP Part Number
W28	<b>CABLE ASSY, CONVERTER OUTPUT, A24A2J3 TO FL1</b> HP 8590L AND HP 8591E (Option 010)	0	08590-20178
	<b>CABLE ASSY, YTF OUT, A3A8J2 TO A3A6J3</b> HP 8592L AND HP 8593E	5	1250-1788
	<b>CABLE ASSY, SYTF OUT, A3A2J2 TO A3A6J3</b> HP 8595E AND HP 8596E	5	1250-1788
W29	<b>CABLE ASSY, LPF/AMPLIFIER, A24FL1 TO A24A3J1</b> HP 8590L AND HP 8591E (Option 010)	0	08590-20186
	<b>CABLE ASSY, FIRST MIXER LOW BAND, A3A6J2 TO FL1J1</b> HP 8592L, HP 8593E, HP 8595E, and HP 8596E	3	08593-20011
	HP 8594E, HP 8594L, and HP 8594Q	4	08594-20011
W30	<b>CABLE ASSY, LPF OUTPUT, FL1J2 TO A3A4J1</b> HP 8592L, HP 8593E, HP 8594E, HP 8594L, HP 8594Q, HP 8595E, and HP 8596E	4	08593-20012
	<b>CABLE ASSY, AMP-DET/ATTN, A24A3 TO A24A4</b> HP 8591E Options 010 and 011	8	08590-20179
W31	<b>CABLE ASSY, ATTN/TG OUT, A24A4 TO J3</b> HP 8591E Options 010 and 011	7	5062-0761
	<b>CABLE ASSY, YTO OUTPUT, A3A7J2 TO A3A13J1</b> HP 8592L, HP 8593E, HP 8595E, and HP 8596E	2	08592-20053
	HP 8593E, HP 8594E, HP 8595E, and HP 8596E (Option 009, 010)	4	08593-20004
	<b>CABLE ASSY, YTO OUTPUT, A3A7J2 TO A3A13J1</b> HP 8594E, HP 8594L, and HP 8594Q	9	08594-20008
W32	<b>CABLE ASSY, ISOLATOR OUTPUT, A3A13J2 TO A3A10</b> HP 8592L	5	08592-20064
	HP 8593E, HP 8595E, and HP 8596E	1	08592-20052
	HP 8594E, HP 8594L, and HP 8594Q	0	08594-20009
	<b>CABLE ASSY, AMPLIFIER-DETECTOR OUTPUT, A24A3 to A7A1J2</b> HP 8590L, HP 8591E, Option 010 and Option 011		8120-5105
	HP 8591C, Option 011		8120-5105

**Table 12-6. Replaceable Cables (continued)**

Reference Designator	Description	CD	HP Part Number
W33	<b>CABLE ASSY, TRACKING GENERATOR POWER</b> HP 8590L, HP 8591C, AND HP 8591E	3	08590-60143
	<b>CABLE ASSY, DIR. CPLR. OUTPUT, A3A10 TO A3A6J4</b> HP 8593E, HP 8594E, HP 8594L, HP 8595E, and HP 8596E	6	08592-20065
	<b>CABLE ASSY, LODA TO DUAL MIXER, A3A14J2 TO A3A6J4</b> HP 8593E, HP 8595E, and HP 8596E (Options 009 and 010)	3	08593-20003
	HP 8594E and HP 8594Q	1	08592-20052
	<b>CABLE ASSY, LODA TO LOW BAND MIXER</b> HP 8594E (Options 009 and 010)	5	08594-20004
W34	<b>CABLE ASSY, YTF DRIVER, A7J301 TO A3A8</b> HP 8592L, HP 8593E, HP 8595E, and HP 8596E	3	08592-60018
W35	<b>CABLE ASSY, 2ND CONV DRIVER, A7J4 TO A3A4J5</b> HP 8592L, HP 8593E, HP 8594E, HP 8594L, HP 8594Q, HP 8595E, and HP 8596E	3	5062-6434
W36	<b>CABLE ASSY, ATTENUATOR DRIVER, A7J5 TO A3A5</b> HP 8592L, HP 8593E, HP 8594E, HP 8594L, HP 8594Q, HP 8595E, and HP 8596E	8	5062-4813
W37	<b>CABLE ASSY, COMB GENERATOR OUTPUT, A3A12 TO J2</b> HP 8592L, HP 8593E, AND HP 8596E	2	08592-20061
W38	<b>CABLE ASSY, LODA DRIVE, A10J2 TO A3A14</b> HP 8593E, HP 8594E, HP 8595E, and HP 8596E (Option 010)	9	08593-60009
W39	<b>CABLE ASSY, TRACKING GENERATOR CONTROL, A10J1 TO A3A15J</b> HP 8593E, HP 8594E, HP8595E, and HP 8596E (Option 010)	5	5062-7715
W40	<b>CABLE ASSY, 600 MHz TRACKING GENERATOR DRIVE, A3A15J8 TO A9J7</b> HP 8593E, HP 8594E, HP 8595E, and HP 8596E (Option 010)	8	8120-5020
W41	<b>CABLE ASSY, FIRST LO, A3A14J3 TO ASA15J4</b> HP 8593E, HP 8594E, HP 8595E, and HP 8596E (Option 010)	2	08593-20002
W42	<b>CABLE ASSY, FIRST LO OUTPUT, A3A15J3 TO REAR PANEL</b> HP 8593E, HP 8594E, HP 8595E, and HP 8596E (Options 009 and 010)	0	5062-7710
W43	<b>CABLE ASSY, TG OUT, A3A16 TO J3</b> HP 8593E, HP 8594E, HP 8595E, and HP 8596E (Option 010)		08593-20009
W47	<b>CABLE ASSY, EXT ALC INPUT, REAR PANEL TO A3A15J6</b> HP 8592L, HP 8593E, HP 8594E, HP 8595E, and HP 8596E (Option 010)	6	08560-60001
W48	<b>CABLE ASSY, SWEEP + TUNE OUTPUT, A7J6 TO REAR PANEL</b> HP 8592L, HP 8593E, HP 8594E, HP 8595E, and HP 8596E (Option 009)	6	8120-5401

**Table 12-6. Replaceable Cables (continued)**

<b>Reference Designator</b>	<b>Description</b>	<b>CD</b>	<b>HP Part Number</b>
<b>W49</b>	<b>CABLE ASSY, TRACKING GENERATOR OUTPUT, A3A15J2 TO A3A16</b> HP 8593E, HP 8594E, HP 8595E, and HP 8596E (Option 010)	8	08593-20008
<b>W50</b>	<b>CABLE ASSY, TG ATTENUATOR DRIVE, A10J3 TO A3A16</b> HP 8593E, HP 8594E, HP 8595E, and HP 8596E (Option 010)	5	8120-5530
<b>W101</b>	<b>CABLE ASSY, TV TRIGGER OUTPUT, A102J2 TO REAR PANEL</b> HP 8591E, HP 8593E, HP 8594E, HP 8595E, and HP 8596E (Option 101)	9	08591-60024
<b>W102</b>	<b>CABLE ASSY, VOLUME CONTROL, A1R1 TO A102</b> HP 8591C, or HP 8591E, HP 8593E, HP 8594E, HP 8595E, and HP 8596E (Option 102)	4	08590-60136
<b>W104</b>	<b>CABLE ASSY, HEADPHONE, A102 TO REAR PANEL</b> HP 8591C, HP 8591E, HP 8593E, HP 8594E, HP 8595E, and HP 8596E (Options 102 and 103)	3	08590-60135
<b>W130</b>	<b>CABLE ASSY, A130 TO A14</b> HP 8591C, HP 8591E, HP 8593E, HP 8594E, HP 8595E, and HP 8596E (Option 130)	8	8120-5020
<b>W131</b>	<b>CABLE ASSY, A130 TO A15J200</b> HP 8591C, HP 8591E, HP 8593E, HP 8594E, HP 8595E, and HP 8596E (Option 130)	0	8120-5030
<b>W132</b>	<b>CABLE ASSY, TV TRIGGER IN, A107J9 TO A102</b> Option 107	4	08591-60078
<b>W133</b>	<b>CABLE ASSY, AUDIO IN, A107P2 TO A26</b> Option 107	2	5062-3447
<b>W134</b>	<b>CABLE ASSY, TV MONITOR OUT, A107J8 TO REAR PANEL</b> Option 107	8	08591-60080
<b>W135</b>	<b>CABLE ASSY, TUNER CONTROL, A107 TO A26 AND A16 TO A107P11</b> Option 107	1	5062-3446
<b>W136</b>	<b>CABLE ASSY, TV IN, FRONT PANEL TO A26</b> HP 8591C (Option 107)	1	08591-60075
	<b>CABLE ASSY, TV IN, REAR PANEL TO A26</b> HP 8590 E-Series (Option 107)	0	5062-3445
<b>W137</b>	<b>CABLE ASSY, TV IF IN, A26 to A107J6</b> HP 8591C (Option 105)	5	08591-60079
<b>W138</b>	<b>CABLE ASSY, GATE TRIGGER IN, REAR PANEL TO A16J501</b> HP 8590 E-Series (Option 105) factory installed time-gated analyzers only	2	08591-60076
<b>W139</b>	<b>CABLE ASSY, GATE OUT, REAR PANEL TO A16J500</b> HP 8590 E-Series (Option 105) factory installed time-gated analyzers only	3	08591-60077

**Table 12-6. Replaceable Cables (continued)**

<b>Reference Designator</b>	<b>Description</b>	<b>CD</b>	<b>HP Part Number</b>
<b>W190</b>	<b>CABLE ASSY, GREY, A190A1 PORT A TO A190A2 PORT A</b> HP 8594Q (Option 190)		8120-6990
<b>W191</b>	<b>CABLE ASSY, RED, A190A1 PORT B TO A190A2 PORT B</b> HP 8594Q (Option 190)		8120-6990
<b>W192</b>	<b>CABLE ASSY, VIOLET, A190A1 PORT C TO A190A2 PORT C</b> HP 8594Q (Option 190)		8120-6990
<b>W193</b>	<b>CABLE ASSY, BROWN, A190A2 IN TO A3 RF ASSEMBLY</b> HP 8594Q (Option 190)		8120-6991
<b>W194</b>	<b>CABLE ASSY, GREEN, A190A2 OUT TO IF ASSEMBLY J4</b> HP 8594Q (Option 190)		8120-8334
<b>W195</b>	<b>CABLE ASSY, RIBBON, A190A2 TO A190A3</b> HP 8594Q (Option 190)		8120-6986
<b>W196</b>	<b>CABLE ASSY, YELLOW, A190A1 TO A16J2</b> HP 8594Q (Option 190)		8120-6990
<b>W197</b>	<b>CABLE ASSY, AUX CONTROL. TO A26J3</b> HP 8594Q (Option 190)		08594-60066
<b>W198</b>	<b>CABLE ASSY, + 5 V TO A26J2</b> HP 8594Q (Option 190)		08594-60082
<b>W199</b>	<b>CABLE ASSY, PREAMP CONTROL, A3A17 TO A26J1</b> HP 8594Q (Option 190)		08594-60065
<b>W200</b>	<b>CABLE ASSY, A3A18 PORT 2 TO A3A9</b> HP 8594Q (Option 190)		08594-20057
<b>W201</b>	<b>CABLE ASSY, A3A18 PORT 3 TO A3A5</b> HP 8594Q (Option 190)		08594-20056
<b>W202</b>	<b>CABLE ASSY, A3A18 PORT 4 TO A26 INPUT</b> HP 8594Q (Option 190)		08594-60065
<b>W203</b>	<b>CABLE ASSY, A3A18 PORT 1 TO A26 OUTPUT</b> HP 8594Q (Option 190)		08594-60065

---

## Component-Level Information Packets

Component-level information is available for selected instrument assemblies. The information for each repairable assembly is provided in the form of Component-Level Information Packets (CLIPs).

A CLIP packet consists of a parts list, component-location diagram, and schematic diagram relating to a unique instrument assembly. An HP part number is assigned to each CLIP packet. When an instrument assembly part number changes, a new CLIP is generated.

### Ordering CLIPs

For ordering convenience, current CLIPs for a specific instrument are combined into Component-Level Information binders. The current set of CLIPs contains information supporting the instrument assemblies manufactured at the time this manual was printed, plus a packet containing general CLIP information.

A complete set of CLIPs can be obtained by ordering the *HP 8590 Series Analyzers Component-Level Repair Service Guide*.

Updated or replacement CLIPs may be ordered through your local Hewlett-Packard Sales or Service office using the CLIP part number provided in Table 12-7.

---

**Note** CLIPs may not be available for recently introduced assemblies.

---

**Table 12-7.  
HP 8590 E-Series and L-Series Spectrum Analyzer  
Board Assembly, Serial Number, and CLIP Part Number Cross-Reference**

Assembly	Instrument Serial Prefix	Board Assembly Part Number	CLIP Part Number
A1A1 Keyboard	All serials	08590-60201*	08590-90204
A3A1A1 Comb Generator	All serials	08569-60026*	08590-90132
A5 Second Converter	All serials	08590-60117*	08590-90117
A5A1 Tripler	All serials	08590-60155*	08590-90117
A7 Analog Interface, RF			
8590L	Serial Prefix 3407A	08590-60197*	08590-90205
8591E	Serial Prefix 3205A	08590-60197*	08590-90205
8591C	Serial Prefix 3325A	08591-60072*	08591-90121
8592L	Serial Prefix 3407A	08592-60097*	08592-90080
8593E	Serial Prefix 3251A	08592-60097*	08592-90080
8593E	Serial Prefix 3205A	08592-60073	08592-90077
8594E/8594L	Serial Prefix 3251A	08594-60030*	08594-90035
8594E	Serial Prefix 3205A	08594-60008	08594-90027
8595E/8596E	Serial Prefix 3304A	08594-60022*	08595-90031
8595E/8596E	Serial Prefix 3205A	08594-60008	08595-90026
A7A1 Tracking Generator Control	All serials	08590-60196*	08590- 90157
*These CLIPs are included in the current component-level repair service guide.			



**Table 12-7.  
 HP 8590 E-Series and L-Series Spectrum Analyzer  
 Board Assembly, Serial Number, and CLIP Part Number Cross-Reference  
 (continued)**

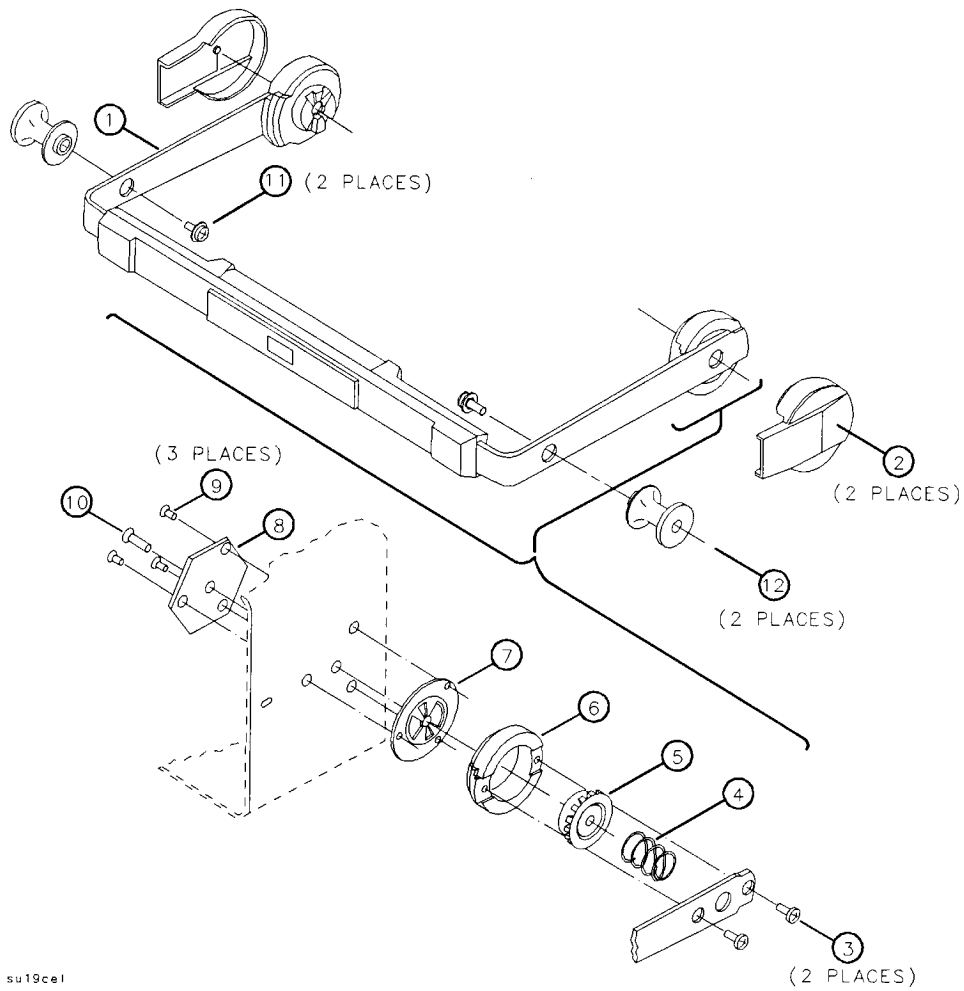
Assembly	Instrument Serial Prefix	Board Assembly Part Number	CLIP Part Number
A9 Third Converter			
Standard:			
8590L	Serial Prefix 3407A	08591-60081*	08591-90120
8591C	Serial Prefix 3325A	08590-60344*	08590-90223
8591E	Serial Prefix 3407A	08591-60081*	08591-90120
8591E	Serial Prefix 3346A	08593-60061	
8591E	Serial Prefix 3205A	08593-60021	08590-90146
8592L	Serial Prefix 3407A	08593-60062*	08593-90054
8593E, 8594E, 8594L, 8595E, and 8596E	Serial Prefix 3407A	08593-60062*	08593-90054
	Serial Prefix 3346A	08593-60061	
	Serial Prefix 3205A	08593-60021	08590-90146
Option 001:			
8590L	Serial Prefix 3407A	08590-60344*	08590-90223
8591E	Serial Prefix 3407A	08590-60344*	08590-90223
8591E	Serial Prefix 3205A	08590-60193	08590-90146
A10 Tracking Generator Control <i>(Options E02 and 010)</i>	All serials	5063-0635	5961-0480
A10 LODA Control <i>(Option 009)</i>	All serials	5062-8232*	08590-90266
*These CLIPs are included in the current component-level repair service guide.			

**Table 12-7.  
HP 8590 E-Series and L-Series Spectrum Analyzer  
Board Assembly, Serial Number, and CLIP Part Number Cross-Reference  
(continued)**

Assembly	Instrument Serial Prefix	Board Assembly Part Number	CLIP Part Number
A11/A13 Bandwidth Filter	All serials	08590-60363*	08590-90231
A12 Amplitude Control	All serials	08590-60105*	08590-90121
A14 Log Amp	Serial Prefix 3520A	08590-60373	5961-0483
A15 Motherboard			
8590L, 8592L, and 8594L	Serial Prefix 3308A	08590-60218*	08590-90217
	Serial Prefix 3205A	08590-60213	08590-90206
8591C, 8591E, 8593E, 8594E, 8595E, and 8596E	Serial Prefix 3308A	08591-60062*	08591-90103
	Serial Prefix 3205A	08591-60060	08591-90087
A16 Processor/Video			
	Serial Prefix 3523A	08590-60365*	08590-90256
	Serial Prefix 3501A	08590-60356	08590-90254
	Serial Prefix 3322A	08590-60342	08590-90224
	Serial Prefix 3303A	08590-60229	
	Serial Prefix 3205A	5062-8276	5961-0843
A16A1 Memory Assembly	Serial Prefix 3523A	08590-60367*	08590- 90265
A17 Memory Card Reader <i>(Option 003)</i>	All serials	08590-60107*	08590-90124
A20 HP-IB I/O <i>(Options 021 and EO2)</i>	All serials	08590-60108*	08590-90125
*These CLIPs are included in the current component-level repair service guide.			

**Table 12-7.  
HP 8590 E-Series and L-Series Spectrum Analyzer  
Board Assembly, Serial Number, and CLIP Part Number Cross-Reference  
(continued)**

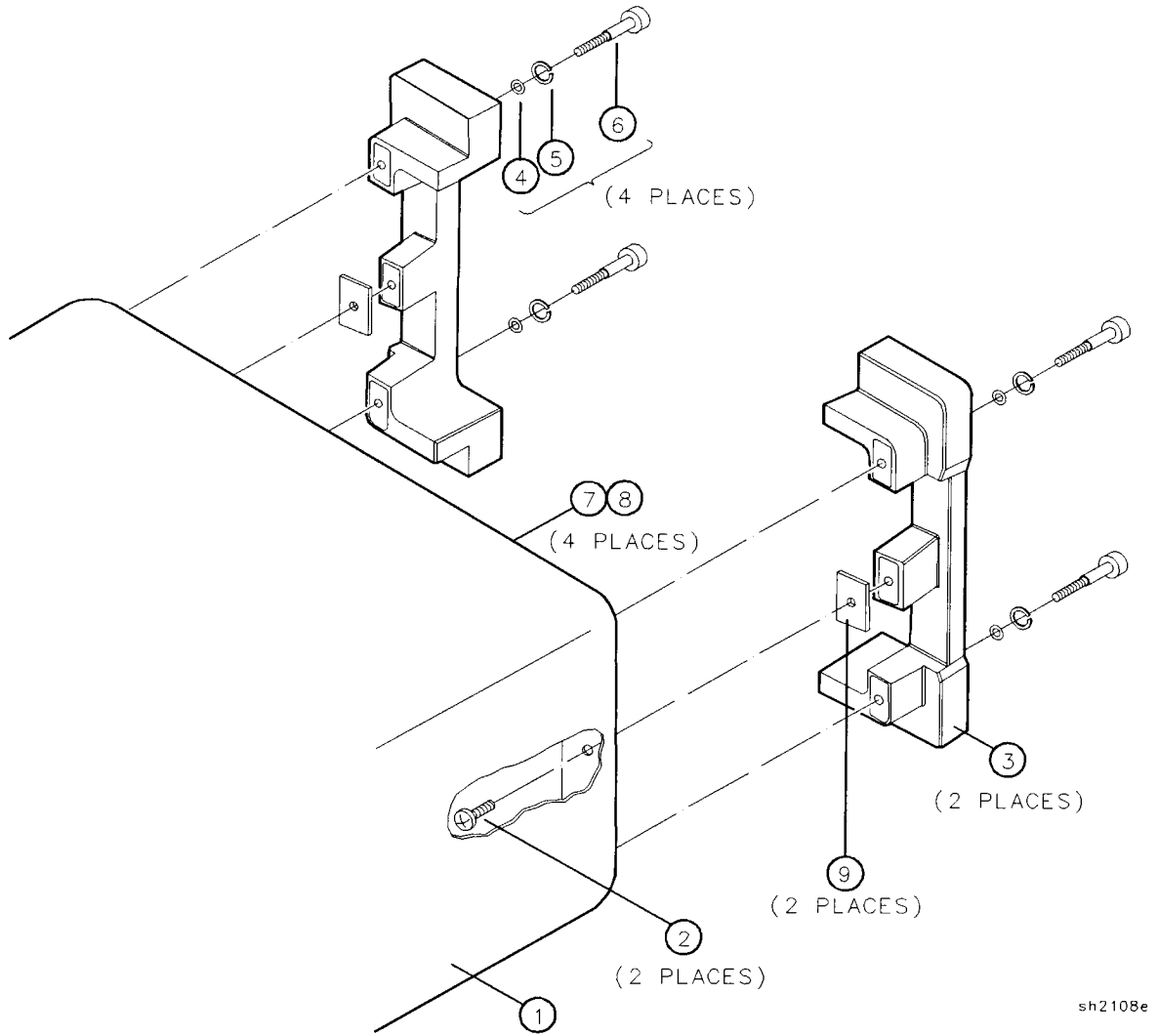
Assembly	Instrument Serial Prefix	Board Assembly Part Number	CLIP Part Number
A21 RS-232 I/O <i>(Option 023)</i>	All serials	08590-60109*	08590-90126
A22 10 MHz Reference	All serials	08591-60048*	08591-90086
A25 Counter Lock			
8590L and 8592L	Serial Prefix 3407A	08591-60073*	08591-90119
All others	Serial Prefix 3249A	08591-60073*	08591-90119
	Serial Prefix 3324A	08591-60061	
	Serial Prefix 3205A	08591-60053	08591-90085
A41/43 Dual I/O	Serial Prefix 3523A	08590-60366	08590- 90257
A101 Fast ADC <i>(Options 101 and 301)</i>	All serials	5062-7079*	5958-7174
A102 AM/FM TV Synch <i>(Options 102 and 301)</i>	All serials	5062-1982*	5958-7055
A103 Demodulator/Quasi Peak Det <i>(Option 103)</i>	All serials	5062-1983*	5960-2504
A105 Gate Card <i>(Option 105)</i>	All serials	5062-7754*	5960-2568
A110 CT2 Board <i>(Option 110)</i>	All serials	5063-0234*	5961-0481
A111 Event Counter <i>(Option 111)</i>	All serials	5063-0214*	5961-0487
*These CLIPs are included in the current component-level repair service guide.			



su19cel

Item	HP Part Number	CD	Description
1	5041-8992	8	HANDLE
2	5041-8912	2	TRIM CAP
3	0515-1114	2	SCREW-MACH M4×0.7 10MM-LG PAN-HD
4	1460-2164	8	SPRING-CPR
5	5021-6343	7	RING GEAR
6	5021-6344	8	SOCKET GEAR
7	5021-8667	2	HANDLE PLATE
8	5001-8728	4	BACKUP PLATE
9	0515-1367	0	SCREW-MACH M4×0.7 8MM-LG FLH-HD
10	0515-1133	5	SCREW-MACH M5×0.8 16MM-LG
11	0515-0382	4	SCREW-MACH M4 12MM-LG PAN-HD (HP 8591C)
12	5022-1122	2	HANDLE BUTTON (HP 8591C)

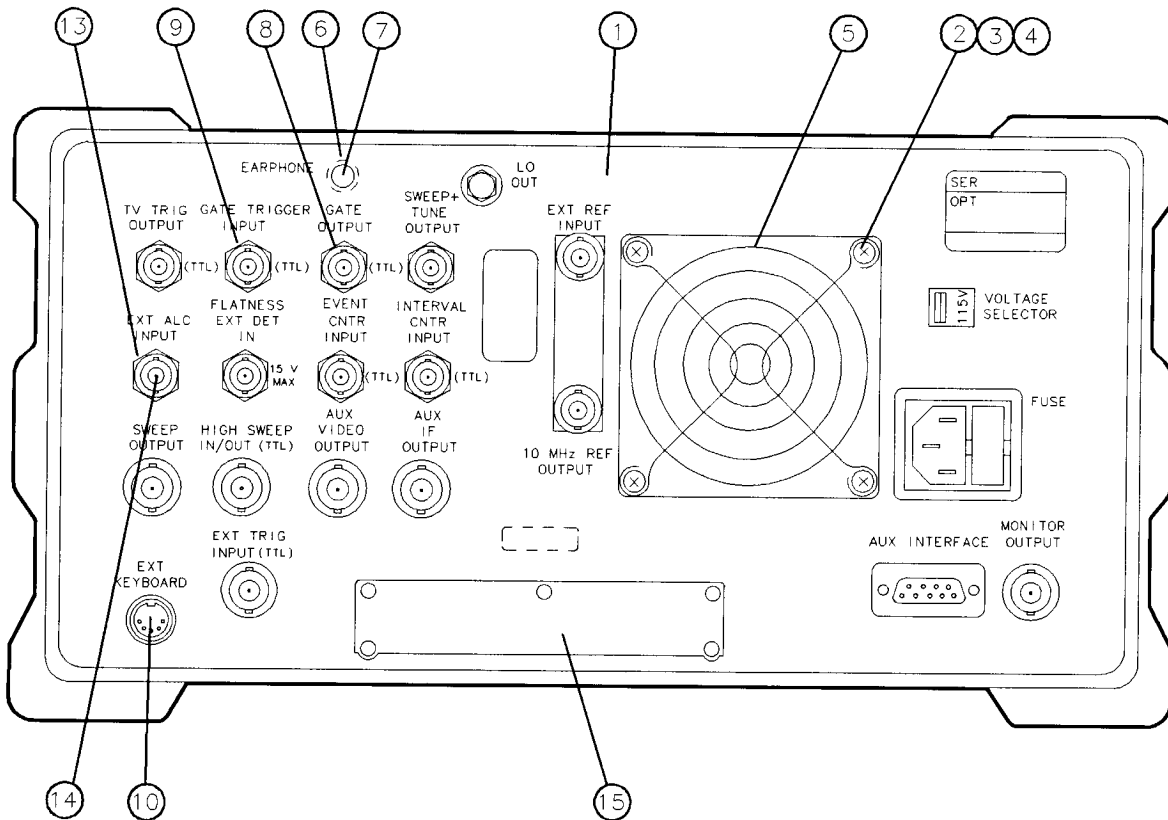
Figure 12-1. Handle Assembly Parts Identification



sh2108e

Item	HP Part Number	CD	Description
	08590-60378		COVER ASSEMBLY
1	08590-00070	3	COVER
2	0515-1114	2	SCREW-MACH M4×0.7 10MM-LG PAN-HD
3	5041-8907	5	REAR FOOT
4	0900-0024	8	O-RING .145-IN-ID .07-IN-XSECT-DIA SIL
5	2190-0587	3	WASHER-LK HLCL 5.0 MM 5.1-MM-ID
6	0515-1218	7	SCREW-SKT-HD-CAP M5.0×0.8 40 MM-LG
7	3050-0893	9	WASHER-FLAT
8	0515-1069	6	SCREW M4.0×10MM PAN-HD
9	08590-40005	2	REAR FOOT SPACER

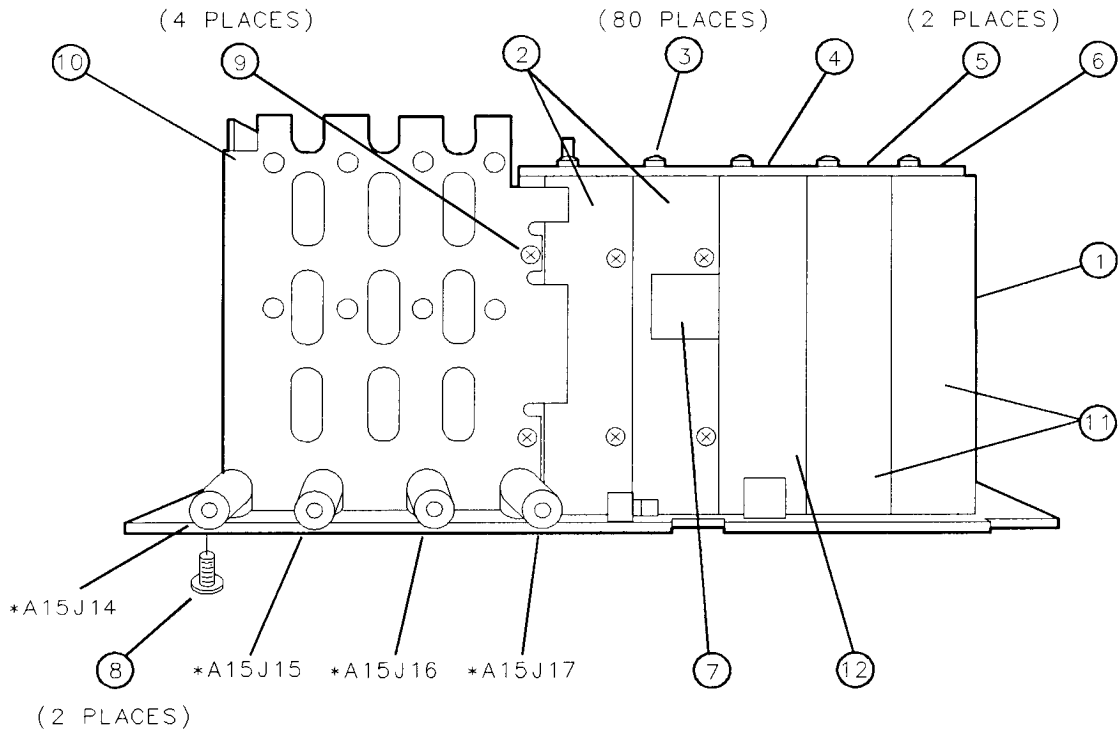
**Figure 12-2. Cover Assembly Parts Identification**



sq16cel

Item	HP Part Number	CD	Description
	08590-60379		REAR FRAME ASSEMBLY (E-Series, L-Series, and HP 8591C only)
1	08594-60058		REAR FRAME ASSEMBLY (HP 8594Q only)
	08590-00062	3	REAR FRAME, DUAL I/O
	5002-0690		REAR FRAME, SINGLE I/O
	08594-00013		REAR FRAME (HP 8594Q only)
2	0380-1900	7	SPACER-ROUND .688L.166ID
3	3050-0105	6	WASHER-FLAT .125ID
4	0515-1038	9	SCREW-MACHINE M3.0 SEMPND
5	3160-0309	5	FAN GRILL
6	6960-0076	2	HOLE PLUG .312D
7	08590-60135	3	MINI-JACK CONNECTOR AND NUT (OPTION 102)
8	0590-1251	6	HEX NUT 15/32-32
9	6960-0150	3	HOLE PLUG 12.7DMM
10	6960-0082	0	HOLE PLUG .922D (NOT ON OPTION 021 OR 023)
11	08590-80012	7	HOLE COVER (NOT ON OPTION 021 OR 023)
12	7120-1232	5	BATTERY LABEL
13	5040-0345	7	INSULATOR CONNECTOR
14	1250-0118	3	CONNECTOR RF FEMALE BNC
15	08590-00065		PLATE (BLANK)

**Figure 12-3. Rear Frame Assembly Parts Identification**

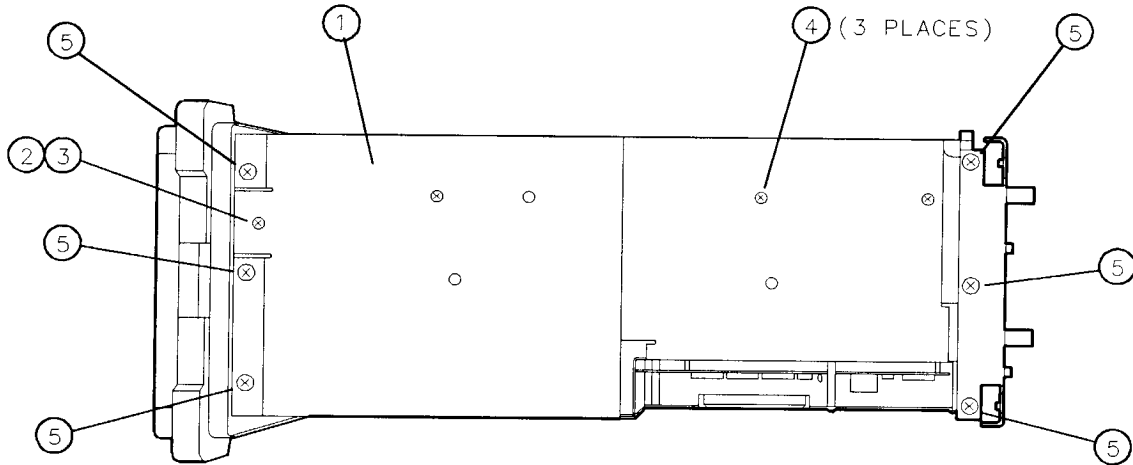


\* REFER TO A15 COMPONENT LEVEL INFORMATION

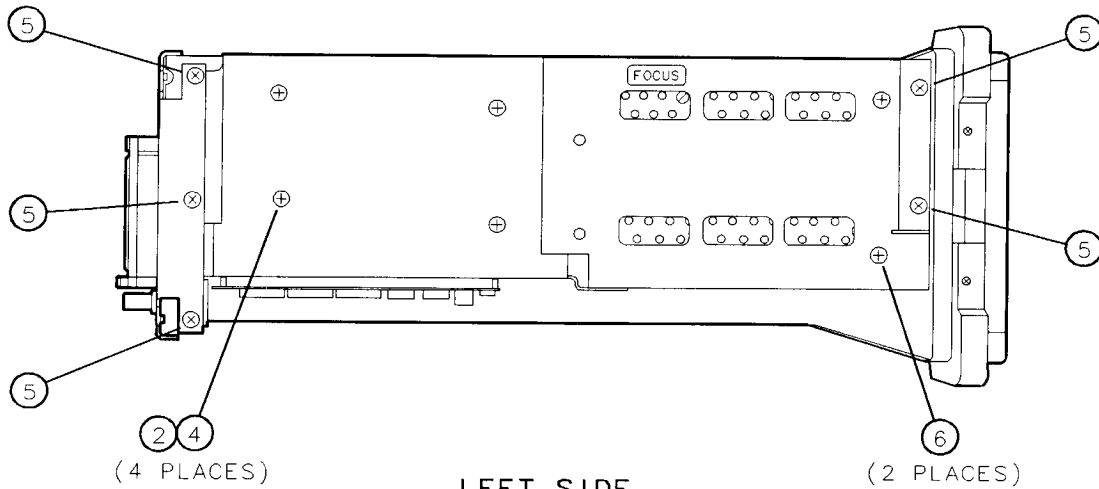
sh2109e

Item	HP Part Number	CD	Description
1	5021-9907	5	EXTRUSION, END PLATE ENCLOSURE
2	5021-9908	6	EXTRUSION, CIRCUIT ENCLOSURE, TAPPED
3	0515-0372	2	SCREW-MACH M3.0 X 8MM
4	5001-8782	0	COVER-AMPLITUDE CONTROL
5	5002-0671	2	COVER-BANDWIDTH FILTER
6	5001-8769	3	COVER-LOG AMPLIFIER
7	1400-0510	8	CABLE CLAMP
8	2360-0526	1	SCREW-MACH 440 .250 PNP
9	0515-0372	2	SCREW-MACH M3.0 X 8MM
10	5001-8767	1	CARD CAGE
11	5021-9395	5	EXTRUSION, CIRCUIT ENCLOSURE
12	5022-0931	9	EXTRUSION, CIRCUIT ENCLOSURE

**Figure 12-4. IF Assembly Parts Identification**



RIGHT SIDE



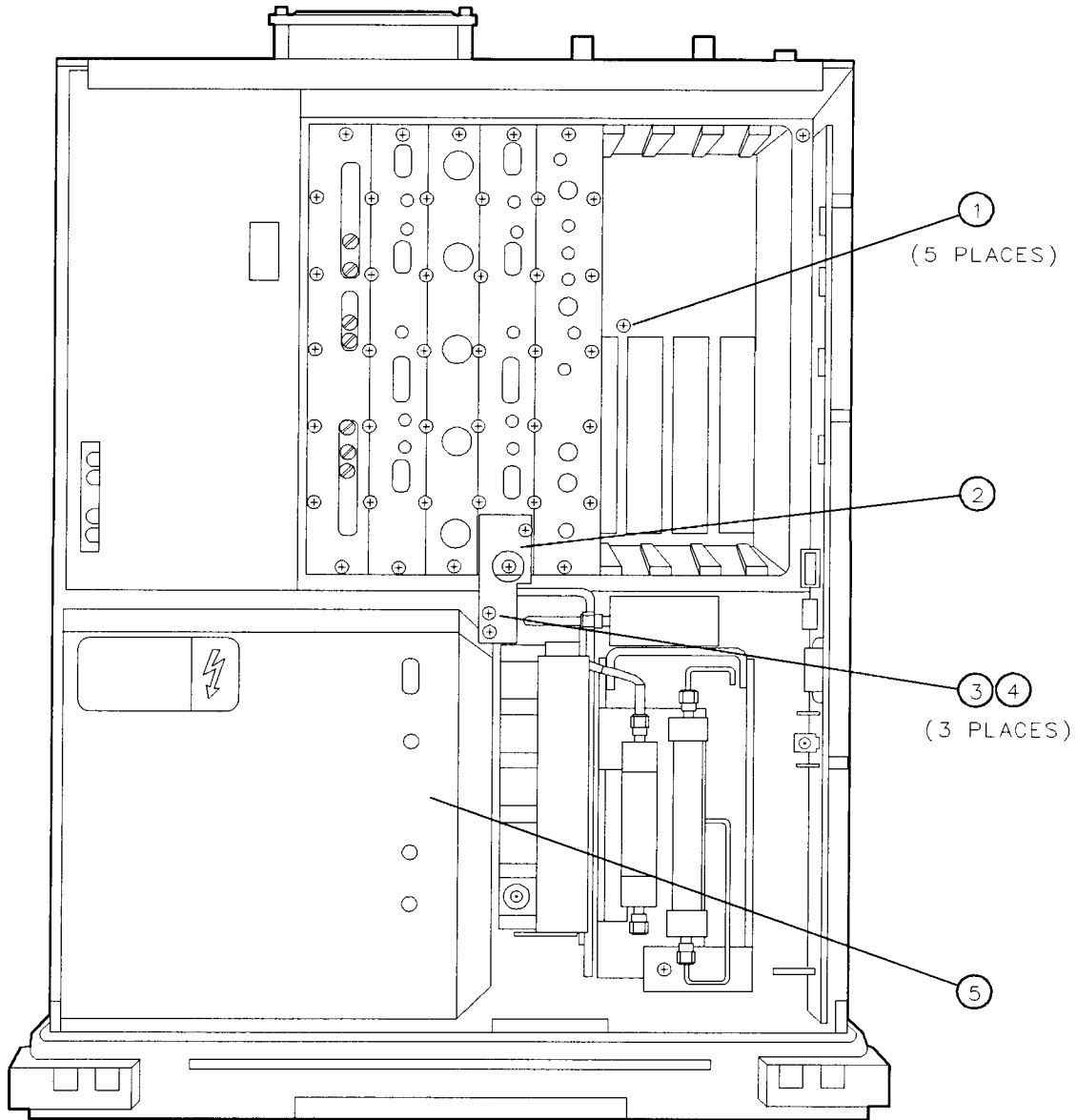
LEFT SIDE

sh2110e

Item	HP Part Number	CD	Description
1	08590-00068	0	CHASSIS
2	3050-0105	6	WASHER-FLAT .125ID
3	0515-1826	3	SCREW-MACH M3.0 x 40 SEMPNPD, HP 8592L, 93E, 94E, 95E, AND 96E
	0515-1468	9	SCREW-MACH M3.0 x 45 SEMPNPD, HP 8590L, HP 8591C, AND 8591E
4	0515-2087	0	SCREW-SQBU M3.0 x 6MM TORX-HD
5	0515-1367	7	SCREW-MACH M4.0 x 8 PCFLPDS
6	0515-0808	9	SCREW-ST M4.0 x 12 PNPD

Figure 12-5. Chassis Side Views Parts Identification

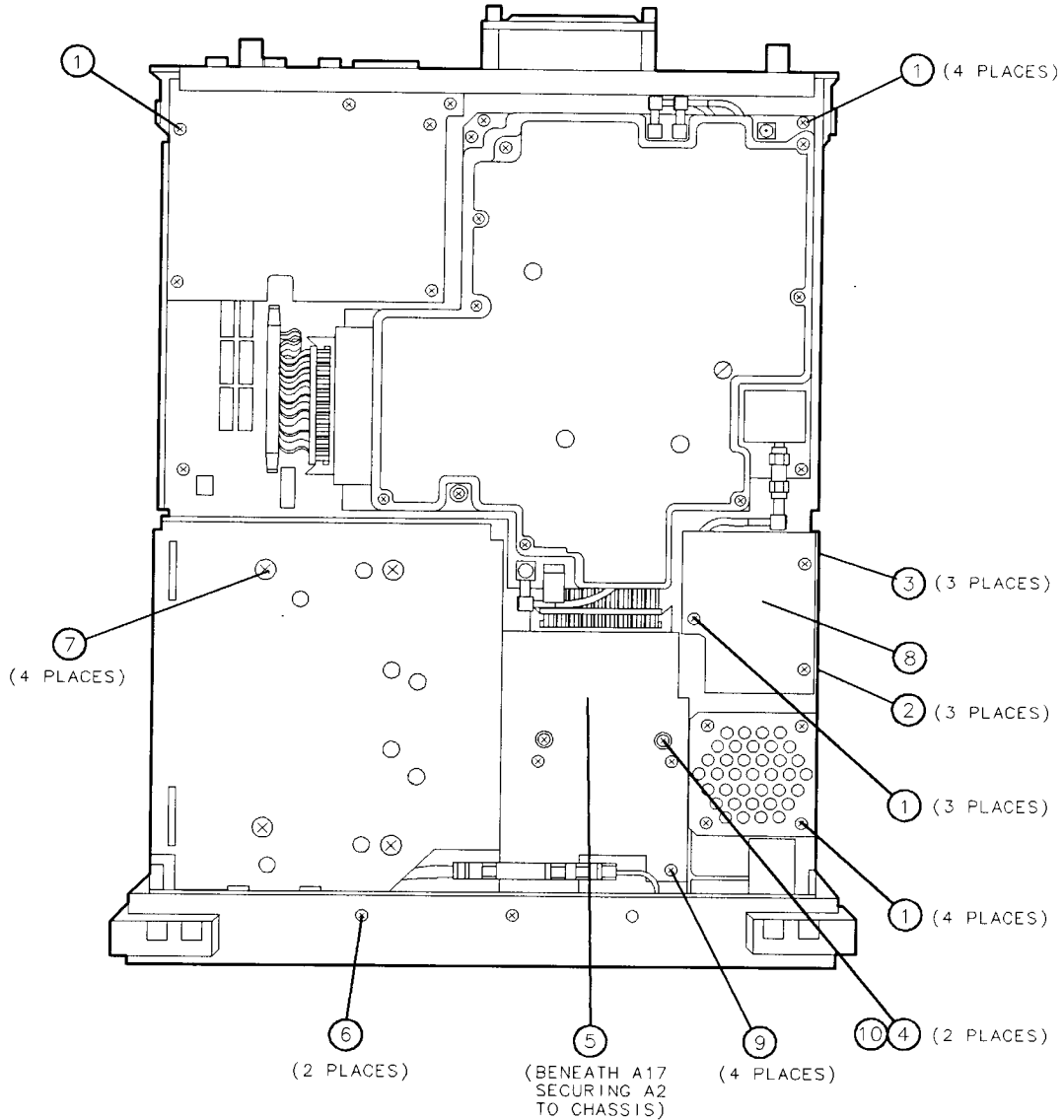




sh2111e

Item	HP Part Number	CD	Description
1	0515-0372	2	SCREW-MACH M3.0 8 CWPNPDS
2	5002-0672	3	FRONT END TO IF SUPPORT BRACKET
3	0515-0372	2	SCREW-MACH M3.0 8 CWPNPDS
4	3050-0893	9	WASHER-FLAT M4.0ID
5	08590-00066	1	DISPLAY SHIELD

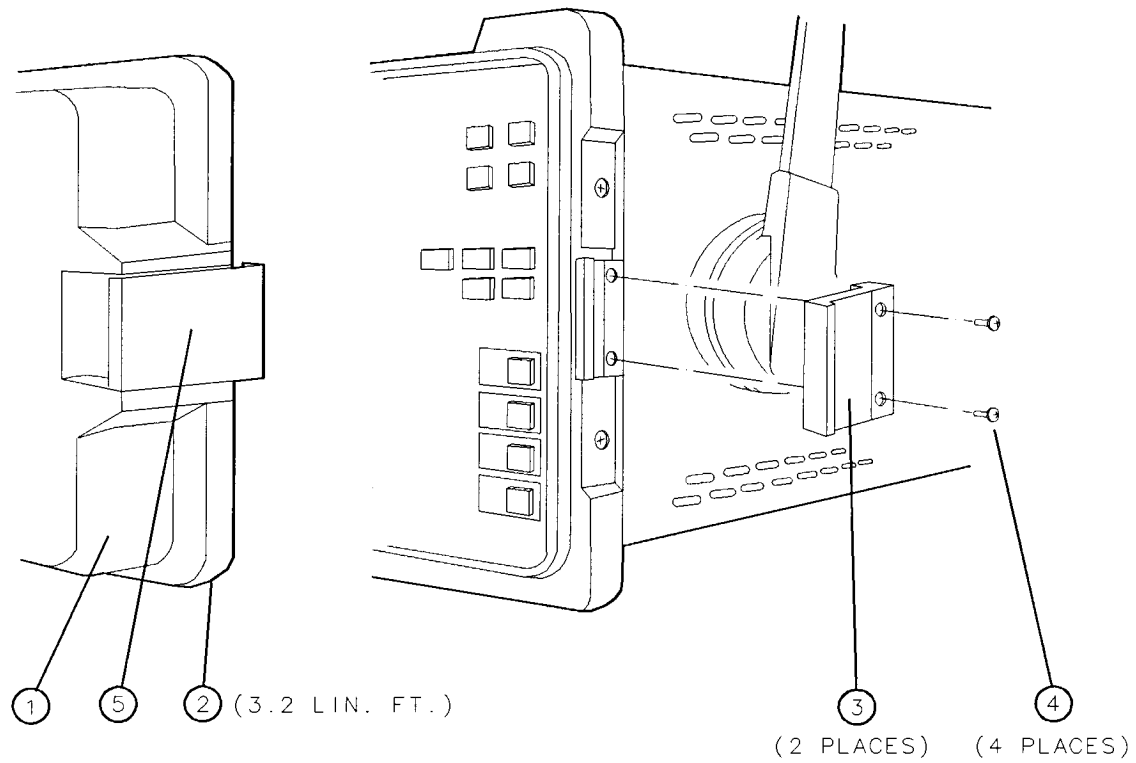
**Figure 12-6. Chassis Top View Parts Identification**



sh2112e

Item	HP Part Number	CD	Description
1	0515-0372	2	SCREW-MACH M3.0 8 CWPNPDS
2	0535-0031	2	NUT-MACH WLKWR M3.0 (STANDARD ONLY)
3	0380-1363	6	STANDOFF (STANDARD ONLY)
4	0515-1453	0	SCREW-MACH M3.0 12 SEMPNPD
5	0515-0808	9	SCREW-ST M4.0 12 PNP
6	0515-1110	8	SCREW-MACH M3.0 12 PCPNPDS
7	0515-0898	7	SCREW-MACH M4.0 6 PCPNPDS
8	5002-0635	8	OCXO MOUNTING BRACKET (OPTION 004 or HP 8591C)
9	0515-0372	2	SCREW-MACH M3.0 8 CWPNPDS
10			WASHER

Figure 12-7. Chassis Bottom View Parts Identification



sh2113e

Item	HP Part Number	CD	Description
1	5062-4805	8	IMPACT COVER ASSEMBLY
2	5041-7235	0	GASKET, 3.2 FT.
3	5021-5483	4	CATCH LATCH
4	0515-0894	3	SCREW-MACH M2.5 6MM-LG PAN-HD
5	5062-0730	0	DRAW CATCH ASSEMBLY

**Figure 12-8. Impact Cover Parts Identification**

**Foldout 12-1 Parts Identification**  
**HP 8592L, HP 8593E, HP 8593E, HP 8596E A3 Front-End Assembly**

Item	HP Part Number	CD	Description
1	0515-0372	2	SCREW-MACH 3.0 x 8MM PAN-HD
2	2360-0123	4	SCREW-MACH 6-23 x .625 PAN-HD
3	5022-0179	7	WASHER, EYO SHOULDER
4	0515-0382	4	SCREW-MACH 4.0 x 12MM TORX
5	1400-0024	9	CABLE CLAMP
6	0515-1462	3	SCREW-MACH 3.0 x 20MM PAN-HD
7	0520-0174	3	SCREW-MACH 2-56 x .25 PAN-HD
8	0515-1373	5	SCREW-MACH 2.5 x 16MM PAN-HD
9	0515-1946	8	SCREW-MACH 3.0 x 6MM PAN-HD
10	2190-0654	5	LOCK WASHER, 2.0MM
11	0535-0069	6	HEX NUT-MACH 2.0MM
12	0515-0973	9	SCREW-MACH 2.0 x 20MM PAN-HD
13	0535-0070	9	HEX NUT-MACH 2.5MM
14	5002-0700	8	RF BRACKET - 4 PIECES

**Foldout 12-2 Parts Identification**  
**HP 8594E and HP 8594L A3 Front-End Assembly**

Item	HP Part Number	CD	Description
1	0515-0372	2	SCREW-MACH 3.0 x 8MM PAN-HD
2	2360-0123	3	SCREW-MACH 6-23 x .625 PAN-HD
3	5022-0179	7	WASHER, EYO SHOULDER
4	0515-0382	4	SCREW-MACH 4.0 x 12MM TORX
5	1400-0024	9	CABLE CLAMP
6	0515-1462	3	SCREW-MACH 3.0 x 20MM PAN-HD
7	0520-0174	3	SCREW-MACH 2-56 x .25 PAN-HD
8	0515-1373	5	SCREW-MACH 2.5 x 16MM PAN-HD
9	0515-1946	8	SCREW-MACH 3.0 x 6MM PAN-HD
10	2190-0654	5	LOCK WASHER, 2.0MM
11	0535-0069	6	HEX NUT-MACH 2.0MM
12	0515-0973	9	SCREW-MACH 2.0 x 20MM PAN-HD
13	0535-0070	9	HEX NUT-MACH 2.5MM
14	5002-0700	8	RF BRACKET - 4 PIECES

**Foldout 12-3 Parts Identification  
HP 8590L, and HP 8591E RF Assembly**

<b>Item</b>	<b>HP Part Number</b>	<b>CD</b>	<b>Description</b>
1	08590-00051	6	RF BRACKET
2	0515-0372	2	SCREW-MACH 3.0 x 8MM PAN-HD
3	2360-0526	1	SCREW-MACH 4-40 x .312 PAN-HD
4	0520-0174	3	SCREW-MACH 2-56 x .25 PAN-HD
5	0515-0380	2	SCREW-MACH 3.0 x 10MM PAN-HD
6	1400-0650	7	CABLE CLAMP

**Foldout 12-4 Parts Identification  
HP 8590L, HP 8591C, and HP 8591E Tracking Generator Assembly**

<b>Item</b>	<b>HP Part Number</b>	<b>CD</b>	<b>Description</b>
1	08590-00037	8	TG BRACKET
2	5002-0621	2	TG ATTENUATOR BRACKET
3	0515-0433	6	SCREW-MACH 4.0 x 8MM TORX
4	0515-1227	8	SCREW-MACH 3.0 x 6MM TORX
5	0520-0174	3	SCREW-MACH 2-56 x .25 PAN-HD

**Foldout 12-5 Parts Identification  
HP 8590 C-Series, E-Series and L-Series Front Frame Assembly**

Item	HP Part Number	CD	Description
1	0515-1622	7	SCREW-SKT-HD-CAP M4×0.7 8 MM-LG
2	5041-8914	4	DISPLAY BEZEL ASSEMBLY
	5041-8962	2	DISPLAY BEZEL ASSEMBLY, (Option 103)
3	1000-0846	5	DISPLAY FILTER
	1000-0897	6	DISPLAY FILTER (OPTION 103)
4	0370-3069	2	RPG TUNING KNOB
5	0370-3079	4	INTENSITY KNOB, HP 8590 L-SERIES ONLY
6	0535-0082	3	NUT-HEX-3/8×32
7	2190-0016	3	WASHER-LK INTL T 3/8 IN .377-IN-ID
8	08590-00060		HP8590L FRONT PANEL-DRESS
	08590-00061		HP8590L FRONT PANEL-DRESS (OPTION 001)
	08591-00015	3	HP8591E FRONT PANEL-DRESS
	08591-00016	4	HP8591E FRONT PANEL-DRESS (OPTION 001)
	08591-00033	5	HP8591C FRONT PANEL-DRESS
	08592-00024		HP8592L FRONT PANEL-DRESS
	08592-00025		HP8592L FRONT PANEL-DRESS (OPTION 026, 027)
	08593-00010	0	HP8593E FRONT PANEL-DRESS
	08593-00009	7	HP8593E FRONT PANEL-DRESS (OPTION 026, 027)
	08594-00002	1	HP8594E FRONT PANEL-DRESS
	08594-60017	1	HP8594L FRONT PANEL-DRESS
	08594-60053		HP 8594Q FRONT PANEL-DRESS (OPTION 190)
	08595-00002	2	HP8595E FRONT PANEL-DRESS
	08596-00001	2	HP8596E FRONT PANEL-DRESS
9	5060-0467	6	PROBE POWER CONNECTOR (M)
10	0590-1251	6	NUT-SPCLY 15/32-32-THD (SECURES W7)
11	1250-1666	8	ADAPTER SMA F TO SMA F
12	0515-2145	1	SCREW-MACH M3.0 8MM-LG PAN-HD
13	5062-4806	9	BUMPER KIT (SET OF 4)
14	2190-0067	4	WASHER
15	2950-0216	7	NUT-HEX 1/4 × 36
16	5041-8917	7	MEMORY CARD BEZEL
16	5041-8936		MEMORY CARD BEZEL (SOLID)
17	5022-0200	5	FRONT FRAME CASTING
17	5022-1114		FRONT FRAME CASTING (8591C)
18	8160-0520	7	GASKET-EMI, 3 FT.
19	0535-0082	3	NUT-HEX 4.0MM
20	2190-0016	3	LOCK WASHER .377ID
21	2950-0043	8	HEX NUT 3/8 × 32
22	1250-2180	3	ADAPTER,(F) SMA TO (F) TYPE N (INPUT 50Ω)
	5063-0230	7	ADAPTER, (F) SMA TO (F) TYPE N (OPTION 027)
	08673-60040	9	ADAPTER, (M) APC 3.5 TO (F) APC 3.5 (OPTION 026)
23	0515-0430	3	SCREW M3.0×6MM TORX
	0515-2145	1	SCREW M3.0×8MM TORX (OPTION 026, 027)
24	5041-8989	3	HP 8590 L-SERIES RUBBER KEYPAD
	5041-8984	8	HP 8590 E-SERIES RUBBER KEYPAD

**Foldout 12-5 Parts Identification**  
**HP 8590 C-Series, E-Series and L-Series Front Frame Assembly**  
**(continued)**

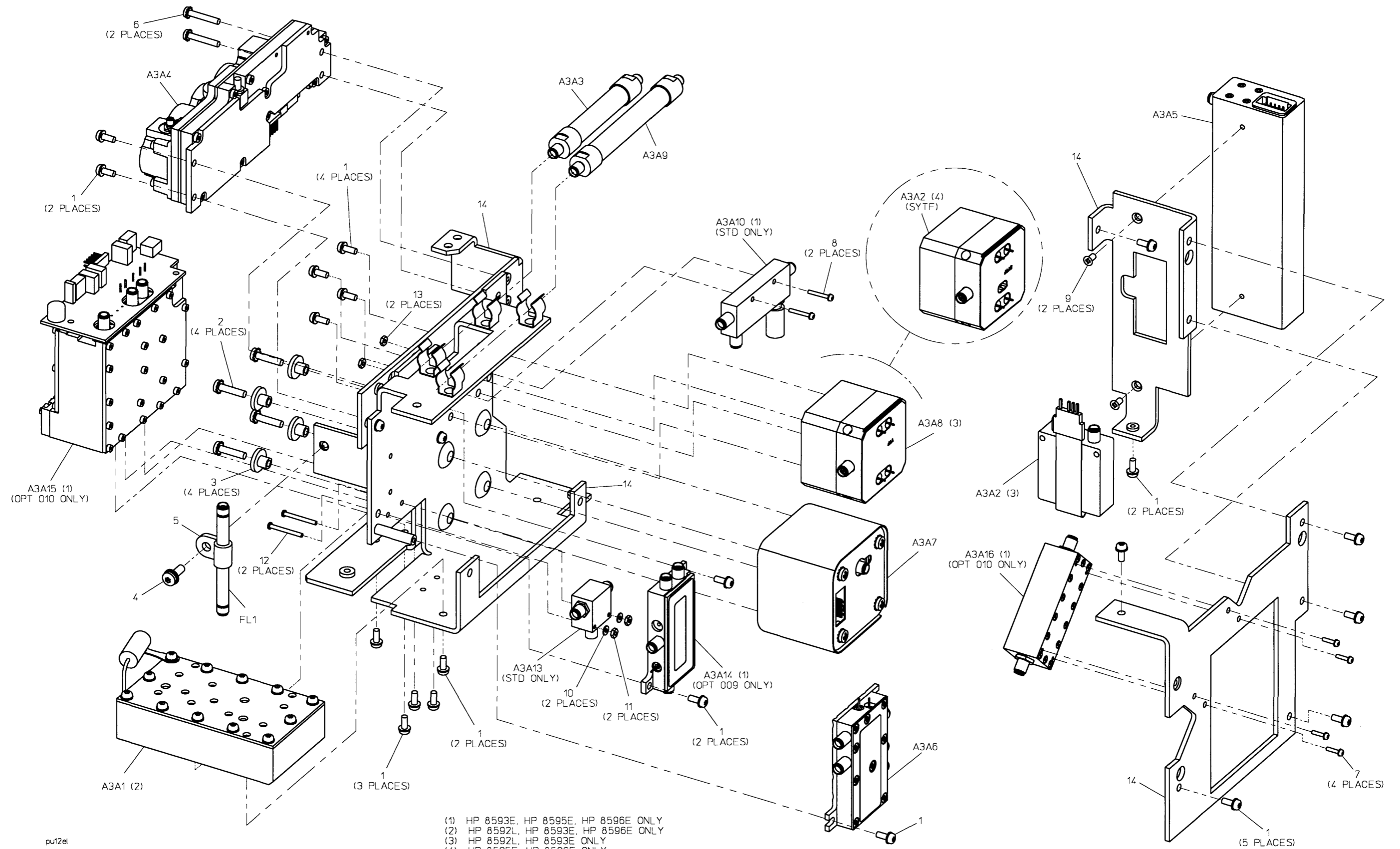
Item	HP Part Number	CD	Description
25	5041-8924	6	VOLUME KNOB, HP 8590 E-SERIES ONLY
26	5041-8925	7	INTENSITY KNOB, HP 8590 E-SERIES ONLY
27	0515-1934	4	SCREW M2.5x6MM TORX
28	08590-60133	1	HP 8590 E-SERIES VOLUME-INTENSITY DUAL-POT ASSEMBLY
	08590-60041	0	HP 8590 L-SERIES INTENSITY POT ASSEMBLY
29	3050-0103	4	WASHER-FLAT .250ID12
30	5021-9320	6	BRACKET - RF INPUT CONNECTOR (OPTION 026)
31	5041-1682		KEYCAP "LINE"

**Foldout 12-6 Parts Identification**  
**HP 8591C RF Assembly**

Item	HP Part Number	CD	Description
1	08590-00034		RF BRACKET
2	0515-0372	2	SCREW-MACH 3.0 x 8MM PAN-HD
3	2360-0526	1	SCREW-MACH 4-40 x .312 PAN-HD
4	2200-0521	8	SCREW-MACH 4-40 x .250 PAN-HD
5	0515-0380	2	SCREW-MACH 3.0 x 10MM PAN-HD
6	0515-0372	2	SCREW-MACH 3.0 x 8MM PAN-HD
7	0520-0174	3	SCREW-MACH 2-56 x .25 PAN-HD

**Foldout 12-7 Parts Identification**  
**HP 8594Q A3 Front-End Assembly**

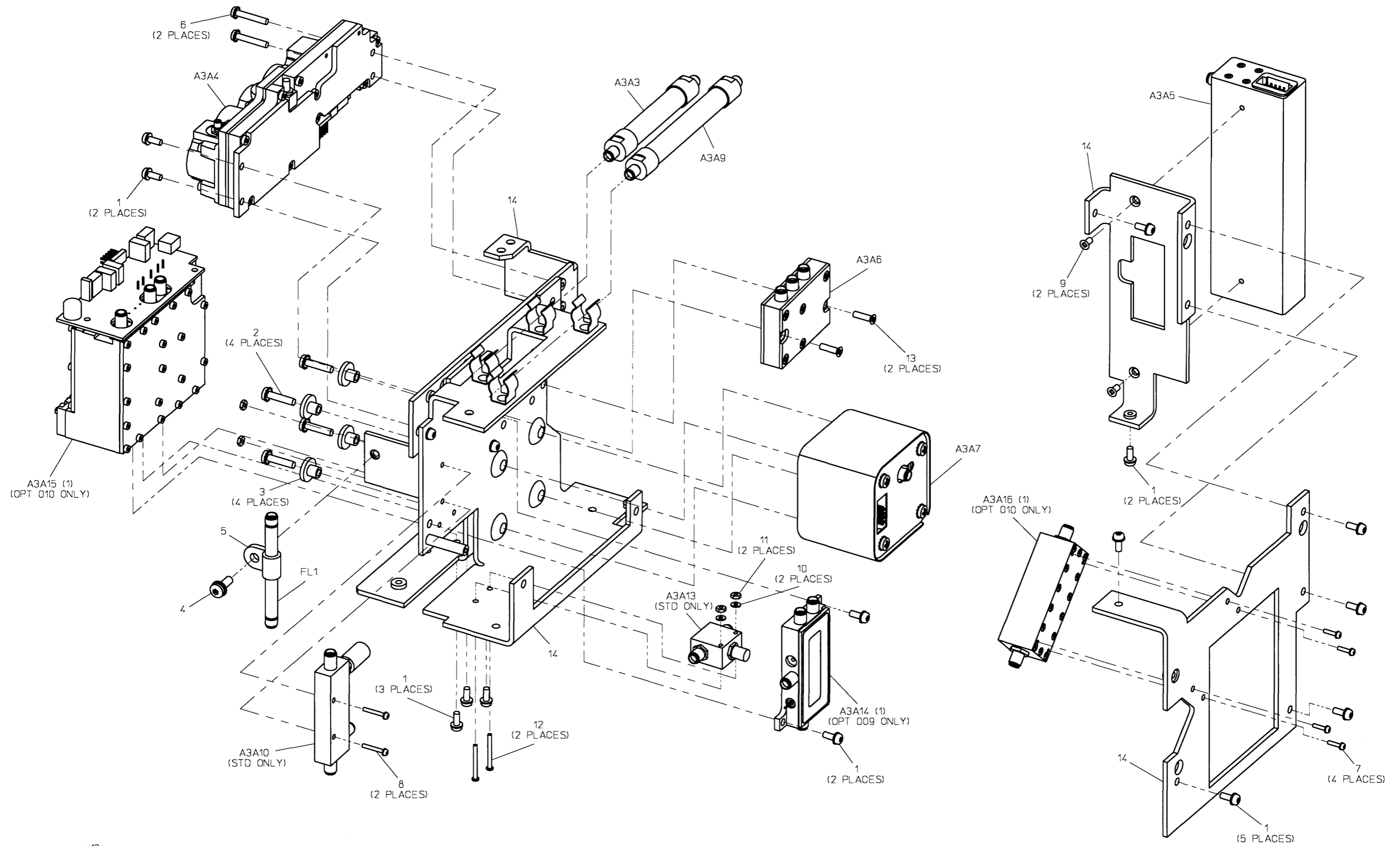
Item	HP Part Number	CD	Description
1	0515-0372	2	SCREW-MACH 3.0 x 8MM PAN-HD
2	2360-0123	3	SCREW-MACH 6-23 x .625 PAN-HD
3	5022-0179	7	WASHER, EYO SHOULDER
4	0515-0382	4	SCREW-MACH 4.0 x 12MM TORX
5	1400-0024	9	CABLE CLAMP
6	0515-1462	3	SCREW-MACH 3.0 x 20MM PAN-HD
8	0515-1373	5	SCREW-MACH 2.5 x 16MM PAN-HD
9	0515-1946	8	SCREW-MACH 3.0 x 6MM PAN-HD
10	2190-0654	5	LOCK WASHER, 2.0MM
11	0535-0069	6	HEX NUT-MACH 2.0MM
12	0515-0973	9	SCREW-MACH 2.0 x 20MM PAN-HD
13	0535-0070	9	HEX NUT-MACH 2.5MM
14	5002-0700	8	RF BRACKET - 4 PIECES



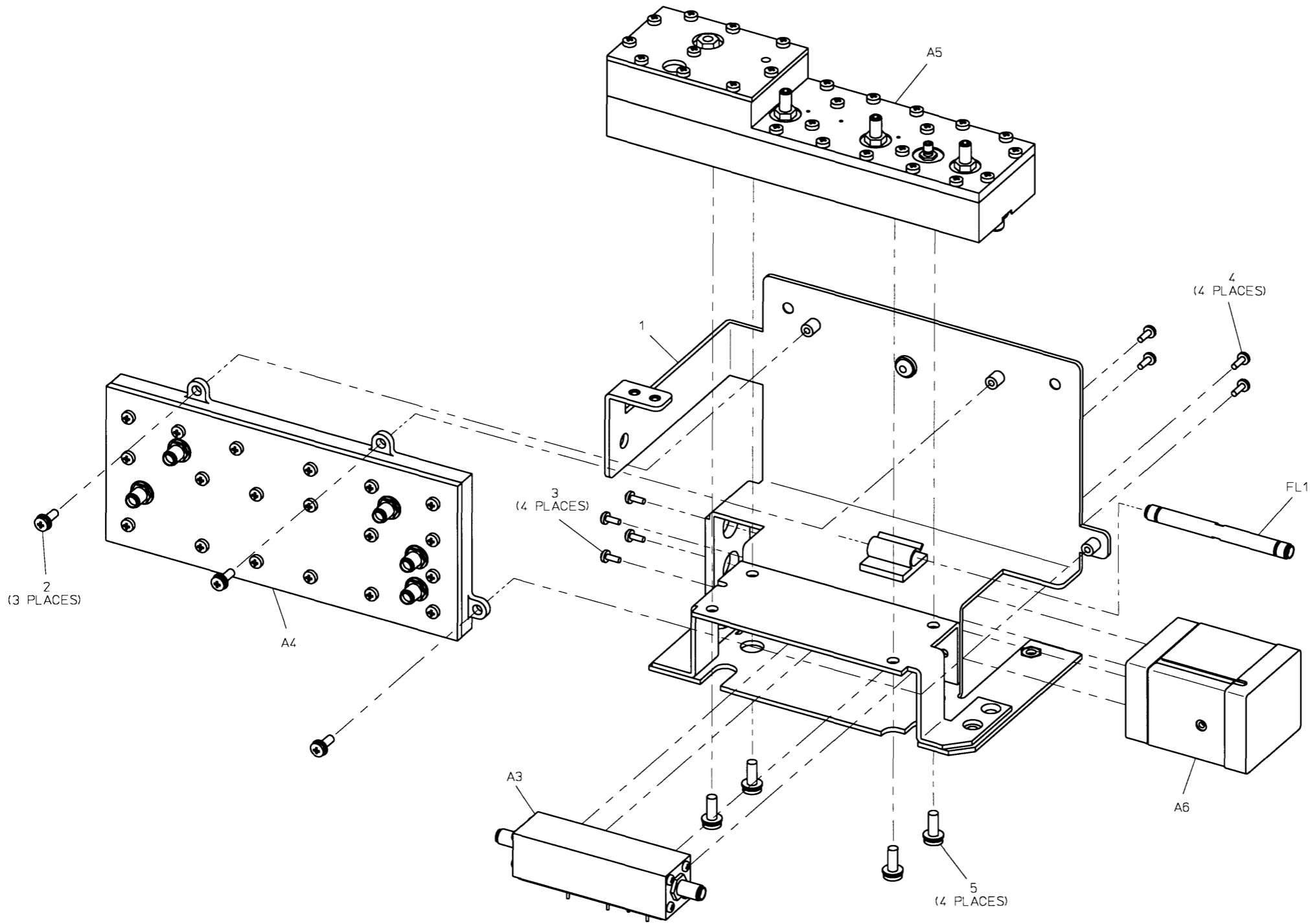
- (1) HP 8593E, HP 8595E, HP 8596E ONLY
- (2) HP 8592L, HP 8593E, HP 8596E ONLY
- (3) HP 8592L, HP 8593E ONLY
- (4) HP 8595E, HP 8596E ONLY

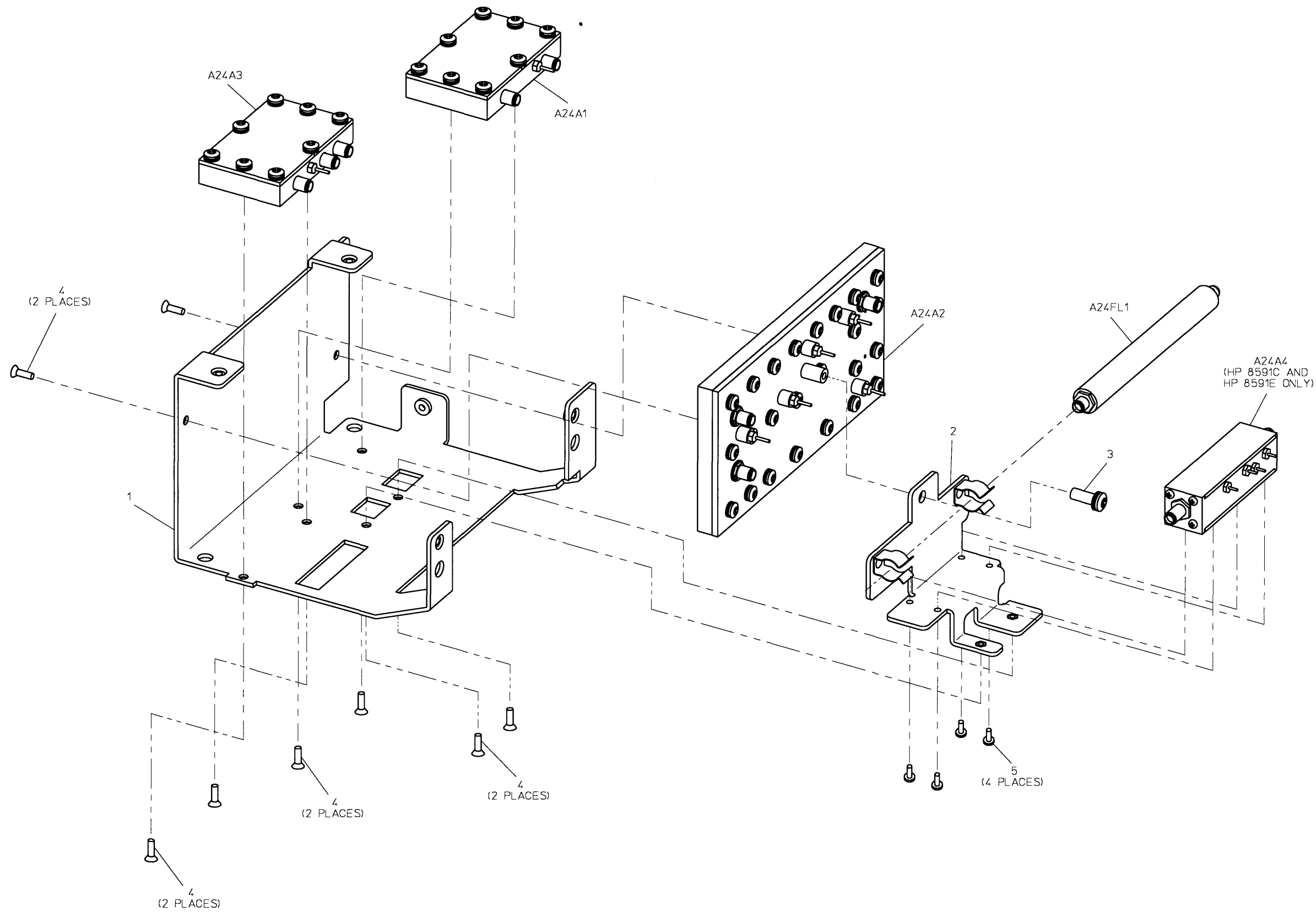
pu12el



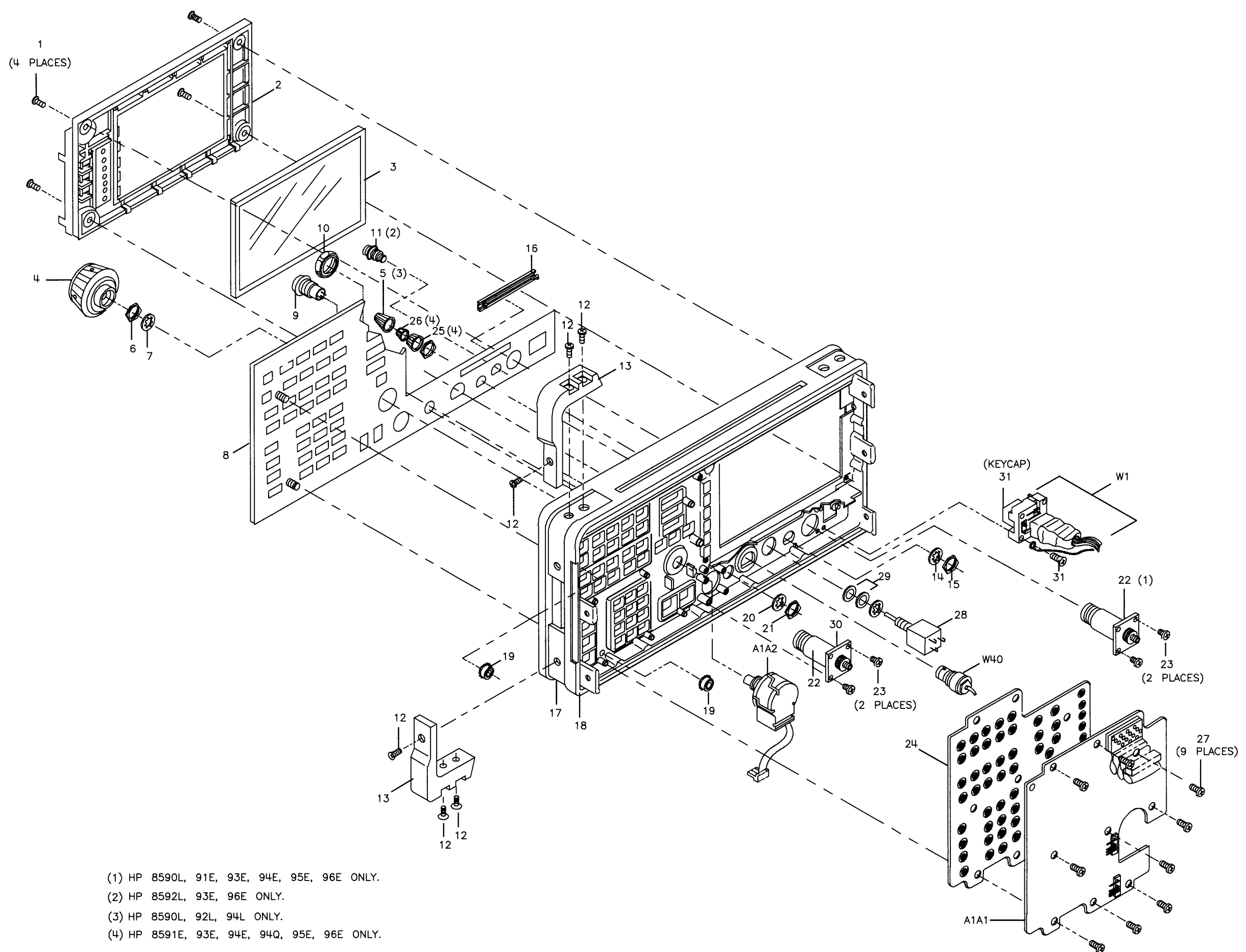


sq12e

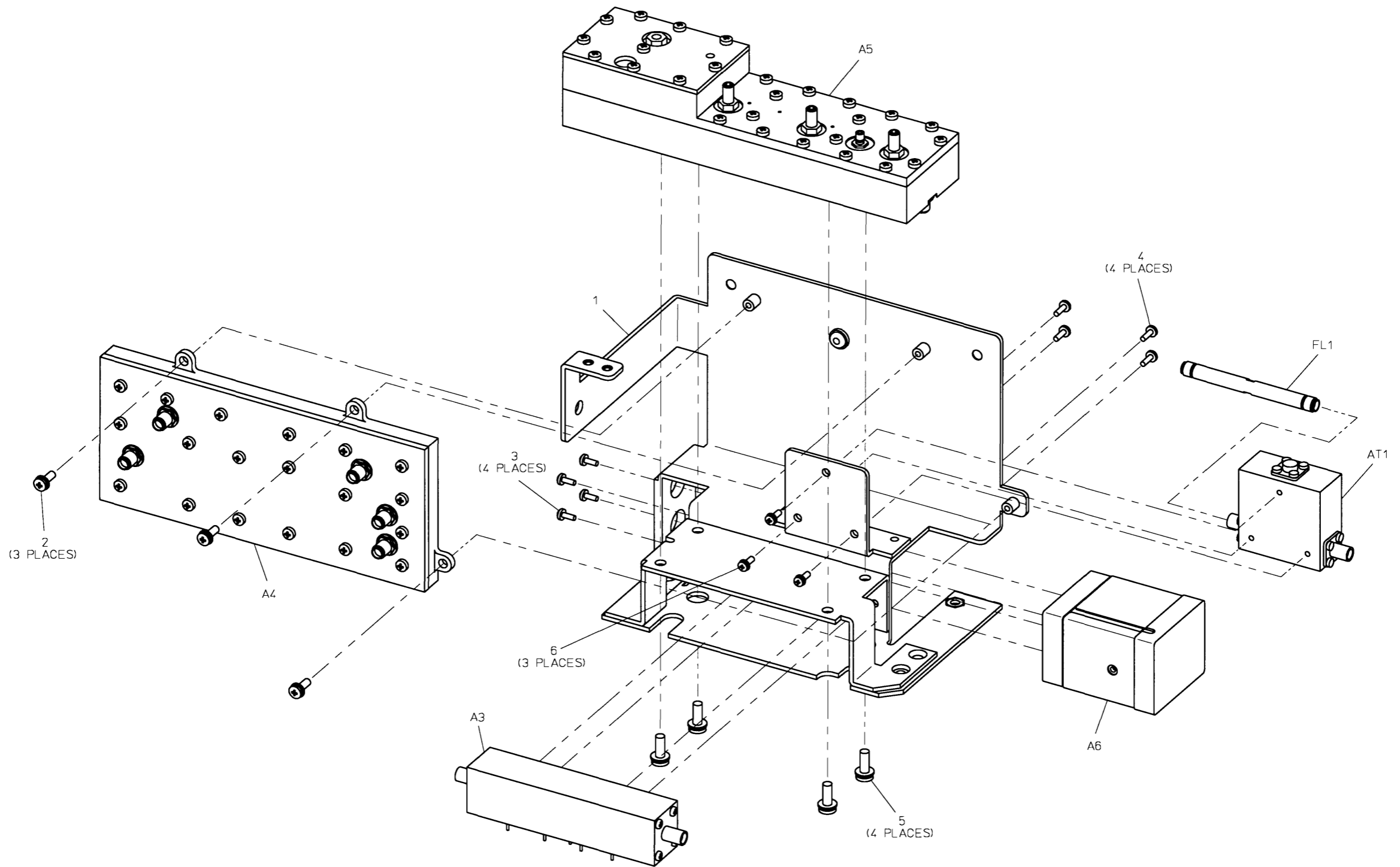




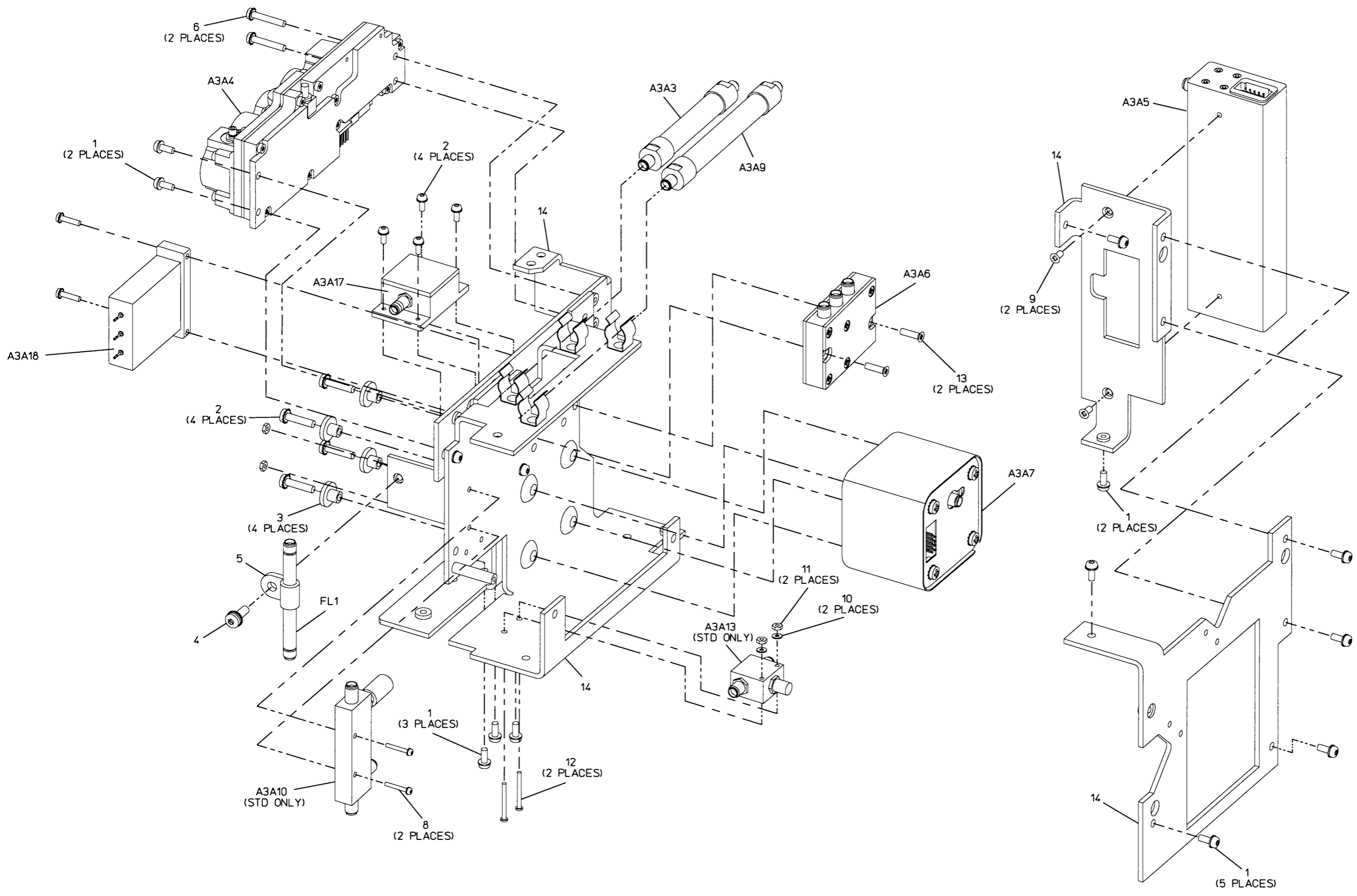
pu11ei



- (1) HP 8590L, 91E, 93E, 94E, 95E, 96E ONLY.
- (2) HP 8592L, 93E, 96E ONLY.
- (3) HP 8590L, 92L, 94L ONLY.
- (4) HP 8591E, 93E, 94E, 94Q, 95E, 96E ONLY.



sh299e



## Softkey Descriptions

---

Refer to this chapter for an explanation of the instrument passcodes, the two types of instrument correction data, and the service-related softkeys that are available after pressing **CAL**.

The calibration, service, and diagnostic softkey functions are listed alphabetically. A list of service-related softkeys follows each softkey description, when appropriate. Refer to the description of each related softkey to understand how the softkey functions interrelate.

---

### Calibration, Service, and Diagnostic Softkey Functions

The front-panel **CAL** key provides the softkey menus for the self-calibration routines, the confidence test, the service-calibration and service-diagnostic routines. Refer to Figure 13-1 and Figure 13-2 for the organization of the softkeys related to **CAL**.

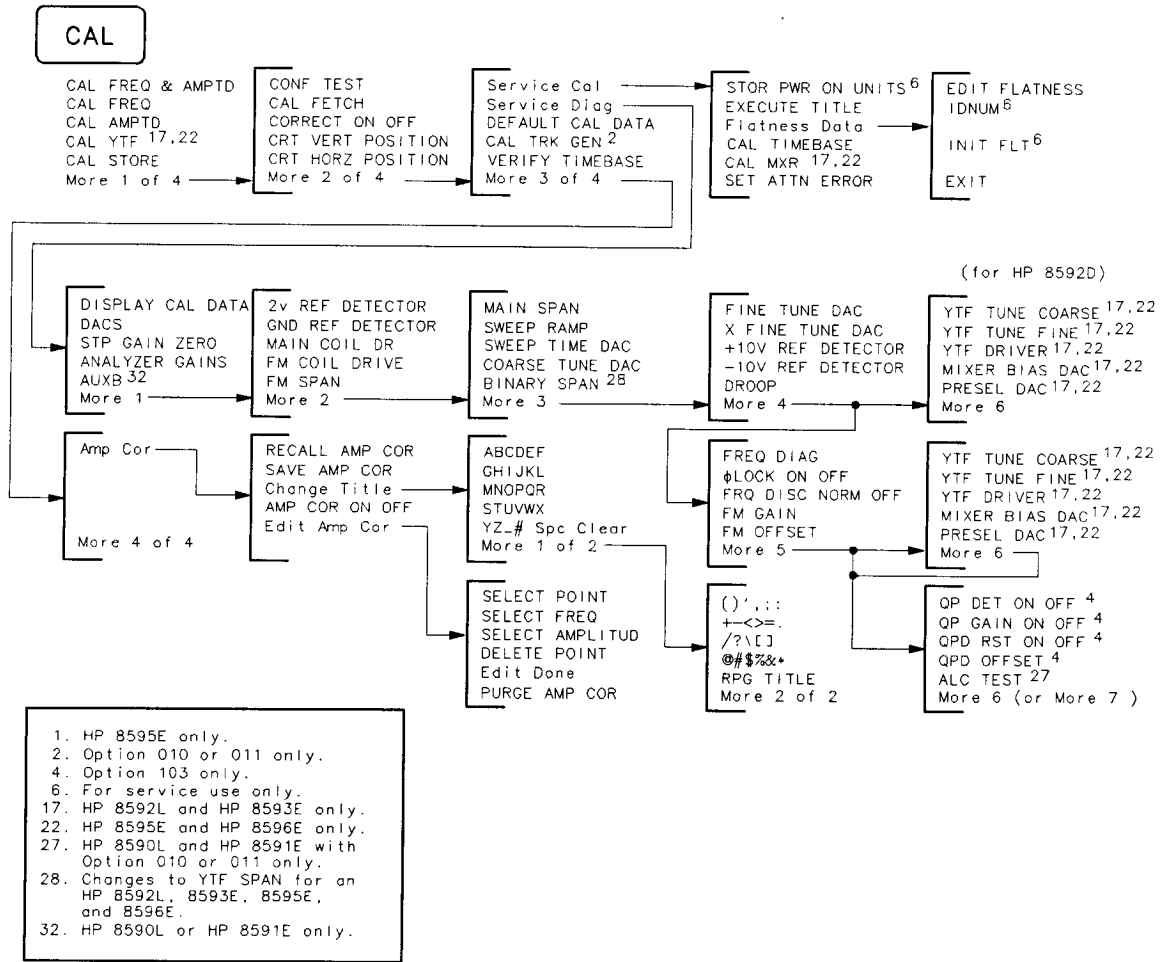
---

**Caution** Correction-constant data can be lost if the **SERVICE CAL** softkeys are used improperly. Refer to the appropriate softkey description for instructions on softkey usage.

---

#### **CAL** Softkey Organization

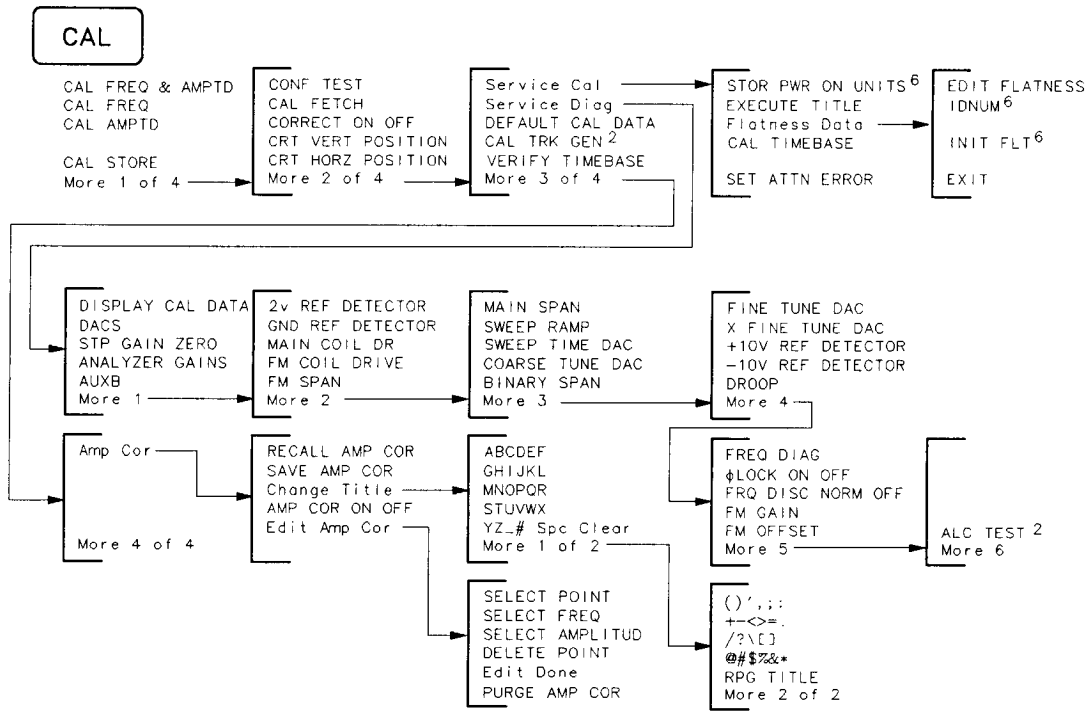
Figure 13-1 and Figure 13-2 provides the organization of all softkeys available after pressing **CAL**. Each block of softkeys represents the softkeys that are displayed at one time. The diagram flow indicates the actual key sequence used for each softkey. The footnotes identify softkeys that appear only when a passcode has been entered or a specific instrument option is installed in the analyzer.



PU14EL

**Figure 13-1.**  
**Calibration, Service, and Diagnostic Softkey Tree: HP 8590 E-Series and L-Series, and HP 8594Q QAM Analyzers**





2. Option 011 only.  
6. For service use only.

pu13c

**Figure 13-2. Calibration, Service, and Diagnostic Softkey Tree: HP 8591C**

---

## Understanding Analyzer Passcodes

Passcodes activate specific softkey functions and protect the correction data from accidental erasure or modification. The two passcodes, -37 Hz and -2001 Hz, are explained below.

### -37 Hz Passcode

Use the -37 Hz passcode to perform the following functions.

- Replace the current calibration-factors with the default calibration data provided by **DEFAULT CAL DATA**.
- Check the accuracy of the 10 MHz frequency reference using **VERIFY TIMEBASE**. Refer to the 10 MHz reference accuracy verification test in the calibration guide for your instrument.
- Bypass the CAL OUT set-up check within individual self-calibration routines.

### -2001 Hz Passcode

Use the -2001 Hz service passcode to perform the following functions.

- Set the start frequency, stop frequency, and step size of the flatness correction points using **INIT FLT**.
- Edit the flatness-correction constants using **EDIT FLATNESS**.
- Edit the A12 amplitude control step-attenuator correction constants using **SET ATTN ERROR**.
- Set the correction factor for the 10 MHz frequency reference (standard timebase).
- Modify the displayed power units that appear when the instrument is first turned on using **STOR PWR ON UNITS**.
- Bypass the CAL OUT signal check within individual self-calibration routines.

## Entering a Passcode

The passcode must be entered before pressing **CAL**. Press the following keys to enter a passcode.

**FREQUENCY**

-37 **HZ** or -2001 **HZ**

**CAL**

When SRVC appears in the lower-left corner of the display, the passcode has been accepted.

---

## Understanding Analyzer Correction Data

The firmware uses correction data to improve instrument performance by minimizing the effect of variations in hardware. There are two categories of correction data.

- Self-calibration correction factors.
- Service-calibration correction constants.

Most correction data can be displayed and modified with the softkey functions provided by **CAL**.

### Self-Calibration Correction Factors

Self-calibration correction factors enhance instrument accuracy by adjusting DACs on the A7 analog interface assembly and by adding offsets to trace information. The correction factor data is stored in nonvolatile memory on the A16 processor/video assembly after pressing **CAL STORE**.

The correction-factor data is produced by the **CAL AMPTD** and **CAL FREQ** self-calibration routines. The horizontal and vertical display positions, adjusted by **CRT VERT POSITION** and **CRT HORZ POSITION**, are also retained.

Refer to the softkey descriptions in this section for further information.

### Service-Calibration Correction Constants

The service-calibration correction constants enhance instrument performance by compensating for frequency-response variation and A12 amplitude control step-attenuation errors. The correction constants are unique for each instrument.

The correction constants for frequency response can be viewed, or modified, using **FLATNESS DATA**. Refer to the frequency response adjustment procedure in Chapter 2 for instructions on generating new correction constants.

The correction constants for step-attenuation errors on the A12 amplitude control assembly can be modified using **SET ATTN ERROR**. Refer to the cal attenuator adjustment procedure in Chapter 2 for instructions on generating new correction constants.

The frequency of the 10 MHz standard timebase, a room temperature crystal oscillator (RTXO), is controlled by a DAC located on the A25 counterlock assembly. Refer to the 10 MHz reference procedure in Chapter 2 to adjust the timebase DAC using **CAL TIMEBASE**.

Analyzers equipped with a A24 Tracking Generator (Options 010 and 011) use two correction constants to improve the performance of the external automatic level control (ALC). Refer to “Entering External ALC Correction Constants (Option 010 and 011)” and “Correcting for External ALC Error for Option 010 and 011” in Chapter 2 for details about the CALTGX slope and offset correction constants.

The initial service-calibration correction constants are stored by the factory in nonvolatile memory on the A16 assembly. After shipment, new correction constants must be manually generated whenever an adjustment or repair affects frequency response or A12 amplitude control step attenuation.

Refer to “After an Analyzer Repair” in Chapter 4 for the specific assemblies that affect frequency response. Whenever the A16 processor/video assembly is replaced, new correction constants must also be generated, unless valid correction constants were saved prior to the instrument failure.

Note that the manual generation of the new service-calibration correction constants is a lengthy procedure. Avoid having to generate new correction constants manually by periodically recording the current correction constants. Refer to Chapter 3 for information about backing up correction constants.

Refer to the softkey descriptions in this section for specific information about the use and modification of the correction-constant data.

---

### **$\phi$ Lock ON OFF Phase Lock On/Off**

**DESCRIPTION** Disables locking of the first LO to allow faster response of the keypad and the sweep when the analyzer has a poor frequency calibration.

Before a normal sweep, the analyzer uses the frequency calibration to set the first LO close to the desired value. It then counts the frequency of the first LO and adjusts it until the correct frequency is achieved within the count resolution. Next, it closes the discriminator if the span is less than 10 MHz, then begins the sweep.

Note that if the frequency calibration is poor, this procedure of locking the LO requires a long time, often many seconds or even minutes. During this time the analyzer does not respond quickly to the keypad. This key disables locking until a frequency calibration can be successfully completed.

When the analyzer determines that the frequency calibration is poor, it automatically disables the first LO lock and the message VLock OFF will appear on screen.

---

### **+10 V REF DETECTOR + 10 V Reference Detector**

**DESCRIPTION** Displays the output of the +10 V reference from the A7 analog interface assembly as a horizontal line along the top graticule.

Refer to Chapter 4 for additional troubleshooting information.

**RELATED SOFTKEYS** **-10 V REF DETECTOR**

---

## **-10 V REF DETECTOR -10 V Reference Detector**

DESCRIPTION	Displays the output of the -10 V reference from the A7 analog interface assembly as horizontal line at the bottom graticule.  Refer to Chapter 4 for additional troubleshooting information.
RELATED SOFTKEYS	<b>+10 V REF DETECTOR</b>

---

## **2v REF DETECTOR 2 V Reference Detector**

DESCRIPTION	Displays the output of the 2 V reference produced on the A16 processor/video assembly as a horizontal line at the top graticule. If the line is at the top graticule, the main ADC is adjusted correctly.  This routine uses the 2 V reference at the input MUX on the A16 assembly. Refer to Foldout 6-2, IF/Control Overall Block Diagram, for the location of the input MUX.  Note that during the preset routine, the analog-ground and 2 V reference are used to calibrate the main ADC. The analog ground and 2 V reference at the input MUX are used during calibration. If either signal is out of range, the ADC-GND FAIL or ADC-2V FAIL error message is displayed.
RELATED SOFTKEYS	<b>CAL AMPTD</b>

---

## **ALC TEST Automatic Level Control TEST**

DESCRIPTION	Note that this function is available for analyzers equipped with Option 010, 50 $\Omega$ Output Tracking Generator, and Option 011, 75 $\Omega$ Output Tracking Generator, only.  <b>ALC TEST</b> breaks the leveling loop for the automatic level control in the tracking generator.  Refer to the modular offset and gain adjustment procedures in Chapter 2 for information on the use of <b>ALC TEST</b> .
-------------	--

---

## Amp Cor Amplitude Correction

**DESCRIPTION**           Accesses the menus for controlling the current amplitude-correction factors. Refer to the *HP 8590 E-Series and L-Series Spectrum Analyzers User's Guide*, for more information about amplitude correction.

---

## ANALYZER GAINS Analyzer Gains

**DESCRIPTION**           Displays the gains of the various sections of the analyzer block diagram for the current settings.

Display Label	Description	Location	Value
RF Atten	RF Attenuator	RF Assembly	0 to -70 dB in 10 dB steps
3rd Conv DAC	Variable Gain	Third Converter	0 to 255 (8 bit DAC)
21.4 Gain	Step Gain	Amplitude Control	0 to 50 dB in 10 dB steps
Cal Atten	Calibration Attenuator	Amplitude Control	0 to -31 dB in 1 dB steps
Lin Gain	Linear Gain	Log Amplifier	0 to 40 dB in 10 dB steps
Nbw S Gain*	Nbw Step Gain	Narrow Bandwidths	0 to 40 dB in 10 dB steps
* Only displayed for Option 130 narrow bandwidths			

---

## AUXB Auxiliary B

**DESCRIPTION**           Note that this function is available for HP 8591C cable TV analyzers and HP 8591E spectrum analyzers only.

Displays the voltage level at an unused input to the Test Point MUX circuitry located on the A7 analog interface assembly. The AUX B input to the A16 processor/video assembly floats to a high positive voltage. When **AUX B** is selected, a horizontal line above the top graticule line, is displayed.

---

## BINARY SPAN Binary Span

DESCRIPTION	<p>Note that this function is available for HP 8590L and HP 8591E spectrum analyzers and HP 8591C cable TV analyzers only.</p> <p>Displays the output of the Span DAC on the A7 analog interface assembly. A ramp is displayed from the upper-left corner to the lower right corner of the display.</p> <p>The instrument span must be set manually before enabling <b>BINARY SPAN</b>.</p> <p>The slope of the ramp increases within each of the following span ranges.</p> <ul style="list-style-type: none"><li>■ 0 Hz to 170 kHz</li><li>■ &gt;170 kHz to 1.7 MHz</li><li>■ &gt;1.7 MHz to 10 MHz</li><li>■ &gt;10 MHz to 170 MHz</li><li>■ &gt;170 MHz to 1.8 GHz</li></ul> <p>Refer to Chapter 6 for further troubleshooting information.</p>
RELATED SOFTKEYS	<b>MAIN SPAN</b> <b>FM SPAN</b>

---

## **CAL** Calibration Key

DESCRIPTION	<p><b>CAL</b> provides access to the softkeys for the self-calibration, service-diagnostics, and service-calibration functions. A passcode is required for access to specific softkeys.</p>
RELATED SOFTKEYS	Refer to Figure 13-1 and Figure 13-2 at the beginning of this chapter for the softkeys that are available after pressing <b>CAL</b> .

---

## **CAL AMPTD** Calibrate Amplitude

DESCRIPTION	<p>Note that if both <b>CAL FREQ</b> and <b>CAL AMPTD</b> self-calibration routines are required, perform the <b>CAL FREQ</b> routine first.</p> <p>The <b>CAL AMPTD</b> softkey initiates an amplitude self-calibration routine. Connect <b>CAL OUT</b> to the analyzer input before pressing <b>CAL AMPTD</b>.</p> <p>During the <b>CAL AMPTD</b> self-calibration routine, messages are sequentially displayed, indicating a specific calibration activity. Each calibration performed by <b>CAL AMPTD</b> is described below.</p>
-------------	---

- While CAL: AMPTD is displayed, the following calibrations are performed:
  - The amplitude error of each resolution bandwidth is corrected using the 3 kHz resolution bandwidth as the amplitude reference. Each amplitude error is then stored as a calibration factor.
  - The center frequency error of each bandwidth is corrected.
  - The top-screen reference level is calibrated using the amplitude of the CAL OUT signal as a reference.
    1. The amplitude of the detected 21.4 MHz IF signal is measured on the A16 processor/video assembly.
    2. The Reference-Level-Calibration DAC on the A7 analog interface assembly adjusts the gain of the IF Calibration Amplifier on the A9 Third Converter assembly to correct the amplitude measured on the A16 assembly.
    3. After the A7 DAC adjusts the A9 output, fine amplitude corrections are made with a digital offset of the video signal on the A16 assembly.
    4. The A7 DAC value and video offset are stored as correction factors on the A16 assembly.
- While CAL: 3dB BW is displayed, the following calibrations are performed:
  - The 3 dB and 6 dB EMI resolution bandwidths are measured.
  - DACs on the A7 analog interface assembly adjust the bandwidth of the LC and crystal filters on the A11 and A13 Bandwidth Filter assemblies.
  - The DAC bandwidth correction factors are stored on the A16 processor/video assembly.
- While CAL: ATTEN is displayed, the following calibrations are performed:
  - The amplitude error of the 10 dB step gains on the A12 amplitude control assembly and the 10 dB linear gains on the A14 Log Amplifier/Detector assembly are corrected.
    - The 10 dB step gain on the A12 assembly is the amplitude reference.
    - Step-gain and linear-gain errors are corrected with digital offsets of the video signal on the A16 assembly.
    - The video offsets are stored as correction factors.
  - Amplitude errors for the A3 Input Attenuator are corrected.
    - The 10 dB step attenuator is the amplitude reference.
    - Input attenuator errors are corrected with digital offsets of the video signal on the A16 assembly.
    - The attenuator offsets are stored as correction factors.



- While CAL: LOG AMP is displayed, the following calibrations are performed:
  - The log fidelity is measured in 1 dB steps.
  - Errors are corrected with digital offsets of the video signal on the A16 assembly.
  - The video offsets are stored as correction factors.

If a failure occurs during this calibration routine, an error message is displayed. Refer to Chapter 14 for the description of displayed error messages.

Be sure to press CAL STORE after running the CAL AMPTD routine.

RELATED SOFTKEYS    DISPLAY CAL DATA

                          CAL FREQ

                          CAL FREQ & AMPTD

                          CAL FETCH

                          CAL STORE

                          CORRECT ON OFF

---

## CAL FETCH Calibration Fetch

DESCRIPTION        CAL FETCH retrieves the self-calibration correction factors from the area of memory that retains data when the analyzer is turned off and places it in working (volatile) RAM memory.

---

**Caution**        Pressing CAL FETCH clears the correction-data-error flag and can permit erroneous data to be stored. Use CAL FETCH only for troubleshooting.

---

RELATED SOFTKEYS    CAL AMPTD

                          CAL FREQ

                          CAL FREQ & AMPTD

                          CAL STORE

---

## CAL FREQ Calibrate Frequency

### DESCRIPTION

**CAL FREQ** initiates the frequency self-calibration routine. Connect CAL OUT to the analyzer input before initiating **CAL FREQ**.

Note that it is normal for the **FREQ UNCAL** error message to appear briefly during **CAL FREQ**.

During the **CAL FREQ** self-calibration routine, messages are sequentially displayed, indicating a specific calibration activity. Each function performed by **CAL FREQ** is described below.

- Before the calibration routine starts, an instrument setup check is performed.

The CAL OUT signal must be within 300 MHz  $\pm$ 50 MHz and greater than or equal to -45 dBm to pass the setup check. If the CAL OUT signal is not present, the routine stops.

If the **DEFAULT CAL DATA** correction factors are in use, a frequency offset may occur that prevents the CAL OUT signal from being found. If desired, the instrument setup check can be bypassed. Enter the -37 Hz passcode before pressing **CAL** and **CAL FREQ**.

Refer to the **CAL SIGNAL NOT FOUND** error message description in Chapter 14 for more information.

- While **CAL: SWEEP** is displayed:
  - The sweep ramp is calibrated.
  - The values are stored as correction factors.
- While **CAL: FREQ** is displayed:
  - Harmonics of the CAL OUT signal are used to adjust the start and stop end-points for the A6 YTO.
  - The end-point values are stored as correction factors.
- While **CAL: SPAN** is displayed:
  - The main-coil sweep sensitivity and span attenuator are adjusted for LO spans greater than 10 MHz.
  - The adjustment routine checks for three displayed signals: 0 Hz, 300 MHz, and 600 MHz. The test passes if all three signals are found within a 750 MHz span.
- **FM DAC Error Check**:
  - The analyzer changes the center frequency setting to move the displayed signal four divisions.
  - If the signal moves within  $\pm 1.25$  divisions of the expected display position, the FM coil drive is within tolerance.

- Instruments equipped with Option 102, AM/FM Speaker and TV Sync Trigger, display the message CAL: FM GAIN + OFFSET. While CAL: FM GAIN + OFFSET is displayed:
  - The FM offset DAC is adjusted to position the signal at center-screen. This calibrates the center screen-position so that it represents an unmodulated signal.
  - The top to bottom screen deviation of a demodulated FM signal, referenced to center screen, is calibrated for a specific frequency deviation.
    - A demodulated signal with a 100 kHz frequency deviation is simulated using the CAL OUT signal and a center frequency step of 100 kHz.
    - The center frequency is stepped up and the FM gain is adjusted to position the signal at top screen.
    - The center frequency is stepped down and the FM gain is adjusted to position the signal at bottom-screen.

If a failure occurs during this calibration routine, an error message is displayed. Refer to Chapter 14 for descriptions of displayed error messages.

Be sure to press **CAL STORE** after running the **CAL FREQ** routine.

RELATED SOFTKEYS

**CAL AMPTD**

**CAL FREQ & AMPTD**

**CAL FETCH**

**CAL STORE**

**DISPLAY CAL DATA**

**FM GAIN**

**FM OFFSET**

---

## CAL FREQ & AMPTD Calibrate Frequency and Amplitude

DESCRIPTION	<p>CAL FREQ &amp; AMPTD initiates both the frequency and amplitude self-calibration routines. Connect CAL OUT to the analyzer input before initiating CAL FREQ &amp; AMPTD .</p> <p>Be sure to press CAL STORE after running the CAL FREQ &amp; AMPTD routine.</p>
RELATED SOFTKEYS	<p>CAL AMPTD</p> <p>CAL FREQ</p> <p>CAL FETCH</p> <p>CAL STORE</p>

---

## CAL MXR Calibrate Mixer

DESCRIPTION	<p>Note that this function is available for HP 8592L, HP 8593E, HP 8595E, and HP 8596E spectrum analyzers only.</p> <p>Be sure to use CAL MXR in the order of adjustment and test routines provided in “After an Analyzer Repair” in Chapter 4 of this service guide.</p> <p>The high-band mixer in the A3A6 Dual-Band Mixer receives a mixer-bias current from a DAC on the A7 analog interface assembly. The mixer-bias current must be adjusted for each frequency band to minimize conversion loss in the A3A6 Dual-Band Mixer.</p> <p>Be sure to use the YTF CAL cable when performing the CAL MXR routine. Refer to the calibration guide for your instrument for the cable part number.</p> <p>The CAL MXR routine adjusts the bias-current DAC setting for the optimum displayed-signal amplitude, using the 100 MHz COMB OUT signal. The routine adjusts the bias current at several frequencies in each band; an optimum bias setting for that band is then determined. During the routine, TRACE A displays the frequency spectrum, while TRACE B displays the signal amplitude versus mixer-bias DAC setting.</p> <p>The -2001 passcode must be entered to activate the CAL MXR calibration routine. Enter the passcode before pressing the <b>CAL</b> key.</p>
-------------	---

Note that the CAL YTF routine must be performed before running the CAL MXR routine. New frequency response correction constants must also be generated whenever the CAL MXR routine is used. Refer to the CAL MXR adjustment routine in Chapter 2 for instructions on the use of the CAL YTF and CAL MXR routines.

Once the CAL MXR routine is finished, the optimum bias-current value for each frequency band is displayed. The displayed values are the mixer bias DAC setting multiplied by 16. The DAC values are automatically stored as correction constants in nonvolatile memory on the A16 processor/video assembly.

RELATED SOFTKEYS    CAL YTF  
                          EDIT FLATNESS

---

## CAL STORE Calibration Store

DESCRIPTION        CAL STORE copies the correction factors from working RAM to the area of memory on the A16 processor/video assembly that retains data after the analyzer is turned off.

---

**Caution**        If the correction factors are not stored, they will be lost when the analyzer is turned off.

---

RELATED SOFTKEYS    CAL AMPTD  
                          CAL FREQ  
                          CAL FREQ & AMPTD  
                          CAL FETCH  
                          CAL TIMEBASE  
                          CRT VERT POSITION  
                          CRT HORZ POSITION  
                          CAL TRK GEN

---

## CAL TIMEBASE Calibrate Timebase

### DESCRIPTION

Note that this function is available for HP 8591 E-Series spectrum analyzers and HP 8591C cable TV analyzers only. Analyzers equipped with Precision Frequency Reference, do not use this softkey function.

Use this softkey to change the setting of the 10 MHz reference (standard timebase) DAC.

The -2001 Hz passcode must be entered to activate this function.

The DAC controls the frequency of the internal 10 MHz oscillator over a frequency range of approximately 65 ppm. At a 10 MHz nominal frequency, one DAC count provides a resolution of less than 0.5 ppm. The DAC has an adjustment range of 0 to 255.

Refer to the 10 MHz frequency reference adjustment procedure in Chapter 2 for further information on the use of CAL TIMEBASE.

Be sure to press CAL STORE to store the time base DAC setting.

### RELATED SOFTKEYS

CAL STORE

DEFAULT CAL DATA

VERIFY TIMEBASE

DISPLAY CAL DATA

---

## CAL TRK GEN Calibrate Tracking Generator

**DESCRIPTION** Note that this function is available for instruments equipped with Option 010, 50 $\Omega$  Output Tracking Generator, and Option 011, 75 $\Omega$  Output Tracking Generator, only.

**CAL TRK GEN** initiates the tracking generator self-calibration routine.

Be sure to perform the **CAL AMPTD** and **CAL FREQ** self-calibration routines before using **CAL TRK GEN**.

Connect the RF OUT from the tracking generator to the RF INPUT using the CAL cable. Refer to Table 1-4 for the part number of the 50 $\Omega$  CAL cable or 75 $\Omega$  CAL cable.

When the **CAL TRK GEN** routine is complete, press **CAL STORE** to store the tracking generator correction factors in nonvolatile memory. The correction factors cannot be viewed.

---

**Caution** If the correction factors are not stored, they will be lost when the analyzer is turned off.

---

**RELATED SOFTKEYS** **CAL AMPTD**

**CAL FREQ**

**CAL STORE**

---

## CAL YTF Calibrate YTF

**DESCRIPTION** This function is available for HP 8592L, HP 8593E, HP 8595E, and HP 8596E spectrum analyzers only.

Note that the user should perform the **CAL YTF** routine if there has been a large change in ambient temperature. Since YTF tracking varies with temperature, the **CAL YTF** routine is required to meet the unpeaked frequency response specification. Refer to the calibration guide for your instrument.

In bands 1 through 4, amplitude accuracy, particularly frequency response, is a function of how well the A3A8 YTF bandpass filter tracks the tuned frequency of the analyzer. YTF tuning is controlled by DACs located on the A7 analog interface assembly. **CAL YTF** minimizes amplitude uncertainty due to YTF tracking by determining the optimum YTF DAC settings for each band.

Be sure to use the YTF CAL cable when performing the **CAL YTF** routine. Refer to the calibration guide for the cable part number.

The **CAL YTF** routine, using the 100 MHz COMB GEN OUT signal (except for the HP 8595E that uses the CAL OUT signal), tunes the analyzer to two frequencies in band 1, and one frequency each in band 2 through band 4. The routine minimizes tracking error by adjusting the YTF coarse- and fine-tune DAC settings for an optimum displayed-signal amplitude in each band. **TRACE A** displays the typical frequency spectrum and **TRACE B** displays the amplitude versus YTF DAC setting.

The routine then sets the analyzer to sweep over the frequency range of each band. The YTF Span DAC is adjusted for the maximum swept-amplitude response in each band. During this part of the routine, **TRACE A** displays the frequency spectrum, and **TRACE B** displays the amplitude versus YTF span DAC setting.

Be sure to press **CAL**, **CAL STORE** after running the **CAL YTF** routine.

**RELATED SOFTKEYS**    **CAL STORE**

**CAL MXR**



---

## COARSE TUNE DAC Coarse Tune DAC

**DESCRIPTION** Displays the analog output of the YTO coarse-tune DAC located on the A7 analog interface assembly. The mnemonic for the control voltage is C\_TUNE.

When **COARSE TUNE DAC** is selected, a horizontal line is displayed in the lower four divisions of the screen. The line represents the 0 V to -10 V DAC output voltage. When the YTO DAC voltage becomes more negative, the YTO frequency is increased, and the displayed line moves lower on screen.

Refer to Chapter 6 for additional LO troubleshooting information.

**RELATED SOFTKEYS** **FINE TUNE DAC**

---

## CONF TEST Confidence Test

**DESCRIPTION** This test automates an informal, visual test that quickly checks the basic operation of six IF and video functions. Each test checks for a simple change in signal position when the analyzer settings for the function under test are changed. Instrument specifications are not used as test limits.

If a test failure occurs, the error message **CONF TEST FAIL** is displayed along with error messages for the failed test. Each check and its corresponding error message are described below.

1. **Positive-Peak Detector Check** and error message **POS-PK FAIL**.

The test checks switching for the positive-peak detector. The noise-floor level should increase when switching from the sample detector to the positive-peak detector.

The test detects the noise-floor increase by statistically comparing the level of the noise floor for the positive-peak detector to the level for the sample detector.

If the error message **POS-PK FAIL** is displayed, the mean of the data from the positive-peak detector is less than the mean from the sample detector data.

2. **Sample-Detector Check** and error message **SAMPLE FAIL**.

The test checks switching for the sample detector. The peak-to-peak amplitude of the noise floor for the sample detector should be wider than the noise floor for the positive-peak detector.

The test detects the wider noise floor by statistically comparing the peak-to-peak amplitude of the noise floor for the sample detector to the noise floor for the positive-peak detector.

If the error message **SAMPLE FAIL** is displayed, the standard deviation of the data from the sample detector is less than the standard deviation of the data from the positive-peak detector.

3. Video-Bandwidth Check and error message VID-BW FAIL.

The test checks video-bandwidth switching by stepping the analyzer from the widest video bandwidth setting to the narrowest. The test detects switching activity by comparing the peak-to-peak amplitude of the noise floor for each video bandwidth.

If the error message VID-BW FAIL is displayed, the peak-to-peak amplitude did not decrease when a narrower video bandwidth was switched on.

4. Resolution-Bandwidth Noise Check and error message RES-BW NOISE FAIL.

The test makes a relative comparison of noise-floor amplitude for each resolution bandwidth.

The test compares the noise-floor amplitude of each resolution bandwidth to that of the next, narrower resolution bandwidth.

If the error message RES-BW NOISE FAIL is displayed, a decrease in the noise floor amplitude did not occur when the test switched to the narrower bandwidth. The test displays the narrower bandwidth as the test failure and displays all bandwidths that fail.

5. A12 Step-Gain Check and error message STEP GAIN/ATTEN FAIL.

The test checks the switching of the step gains on the A12 amplitude control assembly. The test does not check step-gain accuracy. The test steps the reference level from  $-60$  dBm to  $+30$  dBm, in 10 dB increments, with the input attenuator set to 60 dB.

The test detects step-gain switching activity by comparing the noise-floor level for each 10 dB step gain.

If the error message STEP GAIN/ATTEN FAIL is displayed, the displayed noise level did not decrease when the reference level was changed.

6. 3 dB Resolution-Bandwidth Check and error message RES-BW SHAPE FAIL.

The test checks the 3 dB resolution bandwidth of the 10 kHz, 30 kHz, 100 kHz, 300 kHz, 1 MHz, and 3 MHz bandwidth filters.

If the error message RES-BW SHAPE FAIL is displayed, the bandwidths that are displayed with the error message are not within  $\pm 20\%$ .

Resolution bandwidth accuracy is a characteristic, not a specification.

Check the failed bandwidths manually using the **3 dB POINTS** softkey.

---

## **CORRECT ON OFF Correction On/Off**

### **DESCRIPTION**

The analyzer corrects for variations in hardware performance in two ways.

- Digital offsets of the video signal on the A16 processor/video assembly.
- Adjustment of the DAC control voltages provided by the A7 analog interface assembly.

The **CORRECT ON OFF** function affects only the digital offsets of the video signal.

The uncorrected performance of individual assemblies can be checked by disabling the correction data. The following corrections are disabled when **CORRECT OFF** is selected.

- Step-gain-error correction factors. New correction factors are produced by the **CAL AMPTD** self-calibration routine.
- Bandwidth-amplitude correction factors. New correction factors are produced by the **CAL AMPTD** self-calibration routine.
- Log-scale-fidelity correction factors. New correction factors are produced by the **CAL AMPTD** self-calibration routine.
- Input-attenuator correction factors. New correction factors are produced by the **CAL AMPTD** self-calibration routine.
- Bandwidth-centering correction factors. New correction factors are produced by the **CAL AMPTD** self-calibration routine.
- Flatness-correction constants. The original constants are placed in the analyzer memory at the factory. New constants must be generated manually using the frequency response adjustment procedure in Chapter 2.
- A12 amplitude control step-attenuator-correction constants. The original constants are placed in the analyzer memory at the factory. New constants must be generated manually using the cal attenuator error correction procedure in Chapter 2.

The **CORRECT ON OFF** function does not affect the following DAC adjustments.

- Resolution bandwidth corrections.
- Reference level amplitude correction.
- YTO frequency and span corrections.
- 10 MHz reference (standard timebase) DAC correction.

Refer to the **CAL AMPTD** description in this chapter and Chapter 4 when the displayed signal exhibits symptoms of either low or high gain.

RELATED SOFTKEYS    **CAL AMPTD**  
  
                          **CAL FREQ**  
  
                          **CAL STORE**  
  
                          **DEFAULT CAL DATA**

---

## **CRT HORZ POSITION CRT Horizontal Position**

DESCRIPTION        The softkey provides an adjustment for the horizontal display position.

- Press **CRT HORZ POSITION** and use the A1A2 knob on the front panel to adjust the display.

If the A1A2 knob is turned too far clockwise, the display will become distorted. This is a normal response; simply readjust the knob counterclockwise.

- If desired, press **CAL STORE** to retain the new display position.

RELATED SOFTKEYS    **CRT VERT POSITION**  
  
                          **CAL STORE**  
  
                          **DEFAULT CAL DATA**

---

## **CRT VERT POSITION CRT Vertical Position**

DESCRIPTION        The softkey provides the following adjustment for the vertical display position.

- Press **CRT VERT POSITION** and use the A1A2 knob on the front panel to adjust the display.
- If desired, press **CAL STORE** to retain the new display position.

RELATED SOFTKEYS    **CRT HORZ POSITION**  
  
                          **CAL STORE**  
  
                          **DEFAULT CAL DATA**

## DACS DACs

### DESCRIPTION

Use **DACS** to change the DAC numbers of the span, YTO coarse-tune, YTO fine-tune, and YTO FM tune DACs located on the A7 analog interface assembly. The following terminator keys are used to select the desired DAC.

YTO Adjustment DAC Selection	Terminator Key
Span DAC	<b>GHz</b>
YTO coarse-tune DAC	<b>MHz</b>
YTO fine-tune DAC	<b>kHz</b>
YTO FM tune DAC	<b>Hz</b>

Press the following keys to select a YTO adjustment DAC.

**SGL SWP**  
**CAL**  
**MORE 1 of 3**  
**MORE 2 of 3**  
**SERVICE DIAG**  
**DACS**

Press the terminator key for the desired DAC.

Each DAC may be set to any integer between 0 and 4095 using the A1A2 knob on the front panel. Use the **↑** and **↓** keys to make large changes in the DAC settings.

- The **↑** key increments the DAC setting in an even binary progression of 0, 2, 4, 8, 16, . . . , 4096.
- The **↓** key decrements the DAC setting in an odd binary progression of 4095, 2047, 1023, 511, . . . , 1.

Refer to Chapter 6 for additional LO troubleshooting information.

### RELATED SOFTKEYS

**COARSE TUNE DAC**  
**FINE TUNE DAC**  
**X FINE TUNE DAC**  
**FM SPAN**  
**MAIN SPAN**

## DEFAULT CAL DATA Default Calibration Data

### DESCRIPTION

The current correction-factor data is replaced in nonvolatile memory by the factory-loaded default calibration data when **DEFAULT CAL DATA** is used. The default data can be used only if a passcode, either -37 Hz or -2001 Hz, has been entered.

There are two types of correction factors that are changed when the default data is used.

- Video offsets. They are used on the A16 processor/video assembly.
- DAC settings. They are used on A7 analog interface assembly.

After entering the passcode and pressing **DEFAULT CAL DATA**, the default data can be viewed using **DISPLAY CAL DATA**. Figure 13-3 through Figure 13-4 provides the screen display of the default-calibration data. Figure 13-5 provides additional information for analyzers equipped with Option 130.

Note that the default calibration data provided below is for an HP 8593E. The default calibration data for your analyzer may be slightly different.

BANDWIDTH		AMPLITUDE						NEXT PAGE
6dB	BWAMP LC XTL	RFATH	SGAIN	LOG	LIN	NBW	DACS	
200H	0.00 0 91	0.00	0dB	0.00				
9K	0.80 128 128	0.00	10dB	0.00	0.00	0.00		
120K	0.00 32 255	0.00	20dB	0.00	0.00	0.00		
		0.00	30dB	0.00	0.00	0.00	STP GAIN ZERO	
3dB	BWAMP LC XTL	0.00	40dB	0.00	0.00	0.00		
10H	1.52 128 128	0.00	50dB	0.00				
30H	1.28 128 128	0.00	60dB					
100H	0.80 128 128	0.00	70dB	MCDLY		10	ANALYZER GAINS	
300H	1.00 128 128							
1K	0.00 0 214	CA	ATT	ERR	BND	GAIN	ERR	
3K	0.00 0 158	1	-0.08		0	130	0.00	
10K	0.00 0 91	2	0.05		1	130	0.00	
30K	0.00 0 34	4	0.12		2	130	0.00	
100K	0.00 42 255	8	0.06		3	130	0.00	
300K	0.00 36 255	16	0.00		4	130	0.00	
1M	0.00 165 255						More 1	
3M	0.00 218 255	HRM	1	2	3	4		
~5M	0.00 240 255	MXRB	1395	40	1549	570	RT	

Figure 13-3. Default Calibration Data: Page 1

```

                                TUNING
                                NEXT
                                PAGE
CAL      300000000  Sweepsens <10M 0.000200000
ZERO    140000000  Sweepsens Wide 0.000001010      DACS
FAST    519000000  Main Coil Sens 0.059500001
MED     1032000000 FM Coilsens Er 1.599999905
SLOW    207250000  Wide Disc Err  4.500000000
PKofst  0          Wdsc sweepsens 0.000500000  STP GAIN
TCXO    -128      EYO a slope   5E-10      ZERO
Last Cal Freq DEFAULTS
Last Cal Amp DEFAULTS
TRACKING GEN  FM DEMODULATION      ANALYZER
                                GAINS
AOFST    0      ZERO 0
XOFST    3095   SLOPE 17500
OCORR    -32640 Narrow BW 2048
ASLOP    1.075999975 Wide BW 2048
FSLOP    0.000000120
XSLOP    0.307900012
                                More 1
                                R

```

Figure 13-4. Default Calibration Data: Page 2

```

                                Narrow Bandwidth
                                DISPLAY
                                CAL DATA
VCXO tune 95      Gain Corr      Width Corr      DACS
Det offset 128   200 Hz  00      Q1  Q2
Log offset 128   10 Hz  152   200 Hz 128 128
Pole CF tune     30 Hz 128   10 Hz 128 128
P0 128          100 Hz 88    30 Hz 128 128  STP GAIN
P1 128          300 Hz 100  100 Hz 128 128  ZERO
P2 128          $G error
P3 128          0 dB  0      ANALYZER
                                GAINS
                                10 dB  0
                                20 dB  0
                                30 dB  0
                                40 dB  0
                                More 1
                                RL

```

Figure 13-5. Default Calibration Data: Page 3 (Option 130 only)

RELATED SOFTKEYS

DISPLAY CAL DATA

CAL FREQ

CAL AMPTD

CAL TIMEBASE

CORRECT ON OFF

# DISPLAY CAL DATA Display Calibration Data

## DESCRIPTION

Displays the current correction-factor data generated by the CAL FREQ and CAL AMPTD self-calibration routines. Refer to Figure 13-6 through Figure 13-8 for an example of typical calibration data displayed when using DISPLAY CAL DATA . Press **PRESET** to exit the data display.

Note that the calibration data provided below is for an HP 8593E. The calibration data for your analyzer may be slightly different.

BANDWIDTH		AMPLITUDE							NEXT PAGE
6dB	BWAMP LC XTL	RFATN	SGAIN	LOG	LIN	NBW		DACS	
200H	-0.03 0 132	0.01	0dB	0.02					
9K	0.69 128 123	0.00	10dB	0.00	-0.13	0.00			
120K	-0.68 50 255	0.08	20dB	0.13	-0.40	0.00			
		0.11	30dB	0.09	-0.34	0.00			
3dB	BWAMP LC XTL	0.21	40dB	0.09	-0.47	0.00	STP GAIN		
10H	1.52 128 128	0.25	50dB	0.03			ZERO		
30H	0.76 68 68	0.26	60dB						
100H	0.72 128 128	0.74	70dB	MCDLY		100	ANALYZER		
300H	0.74 128 128						GAINS		
1K	-0.06 0 223	CA ATT ERR	BND GAIN ERR						
3K	-0.06 0 167	1	-0.08	0	195	-0.19			
10K	0.00 0 102	2	0.05	1	195	-0.19			
30K	-0.22 0 37	4	0.12	2	195	-0.19			
100K	-0.50 61 255	8	0.06	3	195	-0.19			
300K	0.09 111 255	16	0.00	4	195	-0.19			
1M	0.25 170 255						More 1		
3M	0.29 229 255	HRM	1	2	3	4			
~5M	0.27 240 255	MXRB	1396	40	1549	570		L	

Figure 13-6. Typical Calibration Data: Page 1

TUNING		NEXT PAGE
CAL	300000000	Sweepsens <10M 0.000180161
ZERO	134090240	Sweepsens Wide 0.000001007
FRST	54534344	Main Coil Sens 0.059369102
MED	1076153336	FM Coilsens Er 1.555047274
SLOW	21484809	Wide Disc Err 4.346552849
PKofst	-13	Wdsc sweepsens 0.000505156
TCXD	-128	EYO a slope 3.02E7
Last Cal Freq	01:41:37 SEP 08, 1992	
Last Cal Amp	01:49:17 SEP 08, 1992	
TRACKING GEN	FM DEMODULATION	ANALYZER GAINS
ROFST	0	ZERO 0
XOFST	3095	SLOPE 16981
OCORR	-32640	Narrow BW 1831
ASLOP	1.075999975	Wide BW 1808
FSLOP	0.000000120	
XSLOP	0.307900012	
		More 1
		L

Figure 13-7. Typical Calibration Data: Page 2



Narrow Bandwidth				DISPLAY CAL DATA	
VCO tune	121	Gain Corr		Width Corr	
Det offset	91	200 Hz	69	01	02
Log offset	116	10 Hz	152	200 Hz	128 123
Pole CF tune		30 Hz	76	10 Hz	128 128
P0	143	100 Hz	72	30 Hz	68 68
P1	125	300 Hz	74	100 Hz	128 128
P2	130	SG error		300 Hz	128 128
P3	142	0 dB	19		
		10 dB	5		
		20 dB	0		
		30 dB	-18		
		40 dB	3		
					STP GAIN ZERO
					ANALYZER GAINS
					More 1
					L

**Figure 13-8. Typical Calibration Data: Page 3 (Option 130 only)**

The following text describes each column of correction data illustrated in Figure 13-6, Figure 13-7, and Figure 13-8. The sections of Figure 13-6, Figure 13-7, and Figure 13-8 that contain numbers retain data that is the same for all analyzers; the data is stored in memory at the factory and cannot be changed.

- **TUNING.** These miscellaneous frequency correction values correct for variations in instrument hardware performance.
- **BW-AMP.** The bandwidth amplitude corrections are mathematical offsets of the digitized video signal on the A16 processor/video assembly. Refer to the **CAL AMPTD** softkey description for more information.
- **LC-XTAL.** The A7 analog interface assembly uses these DAC values to adjust the bandwidths of the 21.4 MHz crystal and LC bandwidth filters on the A11 and A13 Bandwidth Filter assemblies. The **CAL AMPTD** self-calibration routine produces DAC values that adjust each bandwidth to within  $\pm 20\%$ .

The 9 kHz and 120 kHz entries are for the 6 dB EMI resolution bandwidths. All other entries are for the 3 dB resolution bandwidths.

Refer to the **CAL AMPTD** softkey description for more information.

- **RFATN.** The input attenuator corrections are mathematical offsets of the digitized video signal on the A16 processor/video assembly.

The 10 dB attenuator step is the amplitude reference used by the **CAL AMPTD** self-calibration routine while calibrating the input attenuator. Refer to the **CAL AMPTD** softkey description for more information about the calibration of the input attenuators.

Refer to “To check control of the A3 input attenuator” in Chapter 6 to identify the attenuators that are in use for a given input attenuation setting.

- **SGAIN.** The step-gain and linear-gain corrections are mathematical offsets of the digitized video signal on the A16 processor/video assembly. The first six entries in the “SGAIN” column are for the 10 dB step gains on the A12 amplitude control assembly. The CAL AMPTD self-calibration routine uses the 10 dB step gain as an amplitude reference while calibrating the step gains.

The last four entries in the “SGAIN” column are for the 10 dB linear gains on the A14 Log Amplifier assembly.

Refer to the CAL AMPTD softkey description for more information about the calibration of the step-gain and linear-gain stages. Refer to “To check IF section gain control” in Chapter 5 to identify the gain stages that are in use for a given reference-level setting.

- **GAIN.** The reference-level-vernier error corrections are DAC values that calibrate the reference level at top-screen during the CAL AMPTD self-calibration routine.

The first five entries are fixed constants. The second five entries provide a coarse gain-adjustment of the A9 Third Converter assembly. Only one DAC value is produced by the calibration routine and is duplicated for all five entries. The A7 analog interface assembly uses the DAC value to adjust the gain of the A9 assembly. The DAC adjustment range is from 0 to 255. The higher the DAC value, the greater the gain on the A9 assembly. Refer to the CAL AMPTD softkey description for more information.

- **ERR.** The ERR column, next to GAIN, is the video offset “fine tuning” of the reference level calibration.
- **CAL ATT ERR.** These error corrections are mathematical offsets of the digitized video signal on the A16 processor/video assembly.

The first five entries in the “CA ATT ERR” column are correction constants that correct amplitude errors for the calibration attenuators on the A12 amplitude control assembly. Currently, the entry for the 16 dB attenuator is not used.

The calibration attenuators on the A12 amplitude control assembly are the amplitude reference for the CAL AMPTD self-calibration routine. The five constants are stored in nonvolatile memory initially at the factory. The constants can be retrieved from, and restored to, nonvolatile memory using the procedures for backing up analyzer correction constants in Chapter 3. When required, new constants are produced using the Cal Attenuator adjustment procedures in Chapter 2.

Refer to the **SET ATTN** softkey description for more information about the calibration attenuators on the A12 assembly.

The second five entries in the “ERR” column are one correction factor that provides a fine adjustment of the reference-level during the **CAL AMPTD** self-calibration routine. The calibration routine produces one video offset and stores it for all five entries.

The video offset is used to make a fine reference-level adjustment after a coarse reference-level adjustment is done using the DAC correction values from “RL-VENR”.

RELATED SOFTKEYS

**CAL FREQ**

**CAL AMPTD**

**DEFAULT CAL DATA**

**CAL STORE**

**CAL FETCH**

**SET ATTN ERROR**

**CAL TIMEBASE**

---

## **DROOP Droop**

DESCRIPTION

Droop disables the reset of the peak detector on the A16 processor/video assembly after each analog-to digital conversion. When an impulse signal is applied, the decrease, or droop, in the peak-detector output is visible. The peak detector will charge up to the peak value of the input signal and then its amplitude will decrease over time.

Refer to Chapter 4 for additional troubleshooting information about the peak detector.

RELATED SOFTKEYS

**CONF TEST**

---

## EDIT FLATNESS Edit Flatness

### DESCRIPTION

---

**Caution** To safeguard the current flatness-correction constants, refer to Chapter 3 for information about backing up analyzer correction constants before using this function.

---

The flatness-correction constants can be viewed or modified using **EDIT FLATNESS**.

- To view the flatness-correction constants, do not enter the passcode before proceeding to **EDIT FLATNESS**.
- To edit the flatness data, enter the –2001 Hz passcode, press **(CAL)** and proceed to **EDIT FLATNESS**.
  1. After pressing **EDIT FLATNESS**, the **STORE FLATNESS** softkey appears, and the flatness data is ready for editing.
  2. Use the A1A2 knob, the **(↑)** key, or the **(↓)** key to move along the frequency range of the analyzer.
  3. Enter the amplitude offset for the desired frequency point and terminate the entry with **(-dBm)** or **(+dBm)**.

---

**Caution** Avoid pressing the **INIT FLT** softkey when pressing the **STORE FLATNESS** softkey. All the flatness-correction constants will be lost if **INIT FLT** is pressed accidentally.

---

4. Store the flatness constants by pressing **STORE FLATNESS**; the new correction constants are stored and an instrument preset is performed.
- Exit the routine at any time by pressing **EXIT**: no changes are made to the existing correction constants and an instrument preset is performed.

Refer to the frequency response adjustment procedures in Chapter 2 for complete instructions related to the flatness-correction constants.

RELATED SOFTKEYS

- INIT FLT**
- STORE FLATNESS**
- FLATNESS DATA**
- EXIT**

---

## **EXECUTE TITLE Execute Title**

**DESCRIPTION** Use **EXECUTE TITLE** to execute remote programming commands that have been entered from the front-panel using **CHANGE TITLE**. Refer to the user's guide, for your instrument, for more information about **CHANGE TITLE**.

**RELATED SOFTKEYS** **CHANGE TITLE**

---

## **EXIT Exit**

**DESCRIPTION** Use **EXIT** to withdraw from a softkey function. No changes are made within the function and an instrument preset is performed.

**RELATED SOFTKEYS** **EDIT FLATNESS**

---

## **FINE TUNE DAC Fine Tune DAC**

**DESCRIPTION** Displays the output of the YTO fine-tune DAC produced on the A7 analog interface assembly.

When **FINE TUNE DAC** is selected, a horizontal line is displayed in the lower four divisions of the screen. The line represents the 0 V to -10 V DAC output voltage. When the YTO DAC voltage becomes more negative, the YTO frequency is increased, and the displayed line moves lower on-screen.

Refer to Chapter 6 for additional LO troubleshooting information.

**RELATED SOFTKEYS** **COARSE TUNE DAC**

---

## FLATNESS DATA Flatness Data

**DESCRIPTION** Provides access to the softkeys used for viewing or editing the flatness correction constants. The -2001 Hz passcode is required when editing the correction data.

---

**Caution** Avoid pressing the **INIT FLT** softkey when pressing the **STORE FLATNESS** softkey. All the flatness-correction constants will be lost if **INIT FLT** is pressed accidentally.

---

**RELATED SOFTKEYS** **EDIT FLATNESS**  
**STORE FLATNESS**  
**INIT FLT**

---

## FM COIL DRIVE FM Coil Drive

**DESCRIPTION** Displays the output of the FM Coil Driver produced on the A7 analog interface assembly. Perform the following steps to observe the output of the FM coil driver For the FM spans (LO spans less than or equal to 10 MHz).

1. Activate **SPAN** before pressing **CAL** to select the **FM COIL DRIVE** function.
2. Press **FM COIL DRIVE** to display a positive-going ramp.
3. Adjust the span setting while observing the displayed ramp. The slope of the ramp increases as the span is increased.

Due to quantization errors, the display appears flat for LO spans less than 500 kHz. For the main-coil spans (LO spans greater than 10 MHz) the display is a flat line.

Refer to Chapter 6 for additional LO troubleshooting information.

**RELATED SOFTKEYS** **FM SPAN**  
**FINE TUNE DAC**  
**X FINE TUNE DAC**

## FM GAIN FM Gain

### DESCRIPTION

Note that this function is available for HP 8593E, HP 8594E, HP 8594Q, HP 8595E, and HP 8596E spectrum analyzers equipped with Option 102, AM/FM Speaker and TV Sync Trigger, only.

This softkey duplicates the functions of the **FM GAIN** key that is accessed using **AUX CTRL**. **FM GAIN** adjusts the top-to-bottom screen deviation range of a demodulated FM signal, referenced to center-screen. The **CAL FREQ** self-calibration routine calibrates the FM screen deviation and modulation offset.

Use **FM GAIN** to do a functional check of the demodulation circuitry. The **CAL OUT** signal can be used in place of a FM modulated signal source.

1. Connect the **CAL OUT** signal to the analyzer input and make the following instrument settings.

**PRESET**  
**FREQUENCY** ..... 300 MHz  
**CF STEP AUTO MAN (MAN)** ..... 500 kHz  
**SPAN** ..... 0 Hz  
**BW** ..... 5 **MHz**  
**AMPLITUDE** ..... -20 dBm

2. Press the following keys.

**AUX CTRL**  
**DEMOD**  
**DEMOD ON OFF (ON)**  
**DEMOD AM FM (FM)**  
**FM GAIN**

When **FM GAIN** is first enabled, it has a 100 kHz deviation from center-screen.


3. Set the maximum deviation from center screen by entering 500 kHz using the data keys, the A1A2 knob, or the **↑** and **↓** keys.

4. Simulate a 500 kHz modulated signal by pressing the following keys.

**FREQUENCY**



If **FM GAIN** is functioning correctly, the displayed signal is deflected from center screen to bottom screen as the center frequency is stepped up 500 kHz from the original center frequency setting.

5. Press the  key twice. The displayed signal moves from bottom-screen to top-screen as the center frequency is stepped down 500 kHz from the original center frequency.

RELATED SOFTKEYS

**DEMOD**

**DEMOD AM FM**

**FM OFFSET**



## FM OFFSET FM Offset

### DESCRIPTION

Note that this function is available for HP 8593E, HP 8594E, HP 8594Q, HP 8595E, and HP 8596E spectrum analyzers equipped with Option 102, AM/FM Speaker and TV Sync Trigger, only.

Use **FM OFFSET** to adjust the horizontal trace for center-screen with no modulation on the carrier. This function is useful for adjusting the carrier offset when **FM GAIN** is set for a modulated signal with a small frequency deviation. The **CAL FREQ** self-calibration routine calibrates an initial center-screen offset.

Use **FM OFFSET** to do a functional check of the demodulation circuitry. The **CAL OUT** signal can be used in place of an unmodulated carrier signal.

1. Connect the **CAL OUT** signal to the analyzer input and make the following instrument settings.

**PRESET**  
**FREQUENCY** ..... 300 MHz  
**SPAN** ..... 0 Hz  
**BW** ..... 5 **MHz**  
**AMPLITUDE** ..... -20 dBm

2. Press the following keys.

**AUX CTRL**  
**DEM0D**  
**DEM0D ON OFF (ON)**  
**DEM0D AM FM (FM)**  
**CAL**  
**MORE 1 of 3**  
**MORE 2 of 3**  
**SERVICE DIAG**  
**MORE 1**  
**MORE 2**  
**MORE 3**  
**MORE 4**  
**FM OFFSET**

3. Adjust the position of the horizontal trace to center-screen using the A1A2 knob.
4. To calculate the actual frequency offset in kHz, multiply the displayed value by 300.

RELATED SOFTKEYS

DEM<sup>OD</sup>

DEM<sup>OD</sup> AM FM

FM GAIN

---

## FM SPAN FM Span

DESCRIPTION

Displays the FM\_SPAN signal from the Span Dividers on the A7 analog interface assembly.

Perform the following steps to observe the FM-SPAN signal for FM spans (LO spans less than or equal to 10 MHz).

1. Activate **SPAN** before pressing **CAL** to select the **FM SPAN** function.
2. Press **FM SPAN** to display a negative-going ramp.
3. Adjust the span setting while observing the displayed ramp. The slope of the ramp increases as the span is increased.

Due to quantization errors, the display appears flat for LO spans less than 500 kHz.

For the main-coil spans (LO spans greater than 10 MHz) the display is a flat line.

Refer to Chapter 6 additional LO troubleshooting information.

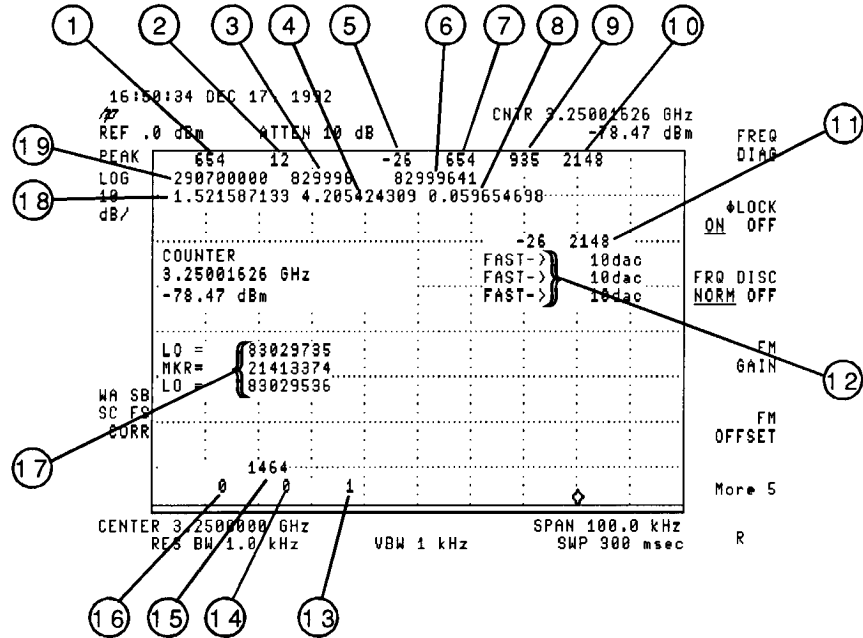
RELATED SOFTKEYS

MAIN SPAN

# FREQ DIAG Frequency Diagnostics

**DESCRIPTION**

Displays, in real-time, frequency diagnostic information for the LO section. Refer to Figure 13-9 for the location of each block of frequency data.



**Figure 13-9. LO Frequency Diagnostic Data Display**

1	Calculated coarse-tune DAC (0-4095)
2	Sampler harmonic number
3	Calculated sampler IF in Hz
4	Wide-band discriminator sensitivity factor
5	Actual frequency error in Hz on last count
6	Actual measured sampler IF in Hz
7	Actual coarse tune DAC number (0-4095)
8	Main coil sensitivity in number of bits per Hz
9	Actual fine tune DAC number (0-4095) Spans >10 MHz, changes from sweep to sweep Spans ≤10 MHz, relatively stable from sweep to sweep
10	Actual extra-fine tune DAC number (0-4095)
11	Indicates which DAC is being adjusted in the iteration process; coarse, fine, or extra-fine.
12	Last iterations of the extra-fine tune DAC. Spans >10 MHz, readout is in frequency Spans ≤10 MHz, readout is DAC number
13	Extra-fine tune DAC iterations to get to correct frequency (not present for spans ≤10 MHz)
14	Fine-tune DAC iterations to get to correct frequency
15	Counter timebase
16	Coarse-tune DAC iterations to get to correct frequency
17	Drift calculation of marker count, a large difference between the two LO counts indicates drift (only present when MKR count is enabled)
18	Discriminator sensitivity factor
19	Sampling oscillator frequency in Hz

Refer to Chapter 6 for additional LO troubleshooting information.

RELATED SOFTKEYS DISPLAY CAL DATA

---

## FRQ DISC NORM OFF Frequency Discriminator Normal/Off

- DESCRIPTION Indicates the status of the frequency discriminator as a function of LO span.
- In LO spans less than or equal to 10 MHz, NORM should be underlined, indicating the discriminator is in use.
  - In LO spans greater than 10 MHz, OFF should be underlined, indicating the discriminator is not in use.

---

## GND REF DETECTOR Ground-Reference Detector

- DESCRIPTION Displays the output of the analog-ground reference produced on the A16 processor/video assembly. A horizontal line at the bottom graticule line indicates that the ADC is adjusted correctly. The ground reference is produced on the A16 processor/video assembly.
- The CAL AMPTD self-calibration routine uses the analog-ground reference to calibrate the bottom-screen level of the main ADC on the A16 processor/video assembly.
- Note that during **PRESET** the analog-ground and +2 V signal are used to calibrate the main ADC. The analog ground and 2 V reference at the input MUX are used during calibration. If the signals are out of range, the ADC-GND FAIL or ADC-2V FAIL error messages are displayed.

RELATED SOFTKEYS CAL AMPTD

---

## IDNUM Identification Number

- DESCRIPTION Note that this function applies only to the HP 8595E and HP 8596E spectrum analyzers. All other analyzers are identified through hardware during analyzer initialization or other means. Refer to Chapter 3 for additional information about analyzer recovery and initialization after a A16 Memory Loss.
- Selects the identity of the analyzer. There is one firmware set for the HP 8590 E-Series and L-Series spectrum analyzers, HP 8591C cable TV analyzers, and HP 8594Q QAM analyzers. By selecting the appropriate identification number (IDNUM), the firmware configures the analyzer to the proper frequency range and analyzer functions.

The following table shows the relationship between the IDNUM and the analyzer model number.

IDNUM	Analyzer
5	HP 8595E
6	HP 8596E

RELATED SOFTKEYS    **INIT FLT 22 GHz**

---

## **INIT FLT Initialize Flatness**

---

**Caution**    To safeguard the current flatness-correction constants, refer to Chapter 3 for more information about backing up analyzer correction constants before using this function.

---

**DESCRIPTION**    Note that this function is available for HP 8590L, HP 8591C, HP 8591E, HP 8594E, HP 8594Q, HP 8595E, and HP 8596E spectrum analyzers only.

Prepares the analyzer memory for the entry of new flatness correction constants. The -2001 Hz passcode is required and must be entered before pressing **CAL**.

**INIT FLT** performs the following functions.

- Sets up the start frequency, stop frequency, and step size of the frequency-response-correction points.
- Initializes A16 memory by entering a default value of 0 dB into memory for all frequency points.

---

**Caution**    The current flatness-correction constants are lost when **INIT FLT** is pressed.

---

RELATED SOFTKEYS    **EDIT FLATNESS**

**STORE FLATNESS**

---

## INIT FLT 22 GHz Initialize Flatness 22 GHz

**DESCRIPTION** Note that this function is available for HP 8592L and HP 8593E spectrum analyzers only.

Prepares the analyzer memory for the entry of new flatness correction constants. The –2001 Hz passcode is required and must be entered before pressing **CAL**.

**INIT FLT 22 GHz** performs the following functions.

- Sets up the start frequency, stop frequency, and step size of the frequency-response-correction points up to 22 GHz.
- Initializes A16 memory by entering a default value of 0 dB into memory for all frequency points.

---

**Caution** The current flatness-correction constants are lost when **INIT FLT** , **INIT FLT 22 GHz** , or **INIT FLT 26.5 GHz** is pressed.

---

**RELATED SOFTKEYS**    **EDIT FLATNESS**

**INIT FLT 26.5 GHz**

**STORE FLATNESS**

---

## INIT FLT 26.5 GHz Initialize Flatness 26.5 GHz

**DESCRIPTION** Be sure to use **INIT FLT 26.5 GHz** for instruments with Option 026, 26.5 GHz extended-frequency range, only.

Prepares the analyzer memory for the entry of new flatness correction constants. The –2001 Hz passcode is required and must be entered before pressing **CAL**.

**INIT FLT 26.5 GHz** performs the following functions.

- Sets up the start frequency, stop frequency, and step size of the frequency-response-correction points up to 26.5 GHz.
- Initializes A16 memory by entering a default value of 0 dB into memory for all frequency points.

---

**Caution** The current flatness-correction constants are lost when **INIT FLT 22 GHz** or **INIT FLT 26.5 GHz** is pressed.

---

RELATED SOFTKEYS

EDIT FLATNESS

INIT FLT 22 GHz

STORE FLATNESS

---

## MAIN COIL DR Main-Coil Drive

DESCRIPTION

Displays the output of the main-coil driver produced on the A7 analog interface assembly. Perform the following steps to observe the output of the main-coil driver.

1. Activate either **SPAN** or **CENTER FREQ**, as needed.
2. Press **CAL** to select the **MAIN COIL DR** function.
3. Change either the span or center-frequency setting and observe the displayed signal.

- When the span setting is increased (For LO spans greater than 10 MHz), the positive slope of the displayed ramp increases.

Due to quantization errors, the display appears flat for LO spans less than 500 MHz.

- When the center frequency setting is increased within a band, the vertical position of the ramp moves up the screen. The vertical position of the ramp is a function of the YTO tune frequency.

The combination of the ramp slope and vertical position represents a voltage that is proportional to the current in the A6 YTO main coil.

Refer to Chapter 6 for additional LO troubleshooting information.

RELATED SOFTKEYS

FM COIL DRIVE



---

## MAIN SPAN Main Span

DESCRIPTION	<p>Displays the main-coil-span signal, MC_SPAN, from the span dividers on the A7 analog interface assembly.</p> <p>Perform the following steps to observe MC_SPAN for the main-coil spans (LO spans greater than 10 MHz).</p> <ol style="list-style-type: none"><li>1. Press <b>SPAN</b> before pressing <b>CAL</b>.</li><li>2. Press <b>MAIN SPAN</b> to display a negative-going ramp.</li><li>3. Adjust the span setting while observing the displayed ramp. The slope of the ramp increases as the span increases.</li></ol> <p>Due to quantization errors, the display appears flat for LO spans less than 100 MHz.</p> <p>For FM coil spans (LO spans less than or equal to 10 MHz), the display is a flat line.</p> <p>Refer to Chapter 6 for additional LO troubleshooting information.</p>
RELATED SOFTKEYS	<b>FM SPAN</b>

---

## MIXER BIAS DAC Mixer-Bias DAC

DESCRIPTION	<p>Note that this function is available for HP 8592L, HP 8593E, HP 8595E, and HP 8596E spectrum analyzers only.</p> <p>Displays the output of the mixer-bias DAC from the first-converter driver on the A7 analog interface assembly. This DAC provides a bias current for the high-band mixer in the A3A6 Dual-Band Mixer. The instrument must be in a single-band sweep for the display to be valid.</p> <p>The top four display divisions represent the DAC range of 0 V to +10 V. A horizontal line, representing the DAC output voltage, is displayed within the top four divisions. The DAC voltage should not change within a frequency band.</p> <p>Refer to Chapter 6 for additional troubleshooting information.</p>
RELATED SOFTKEYS	<b>CAL MXR</b>

---

## PRESEL DAC Preselector DAC

**DESCRIPTION** Note that this function is available for HP 8592L, HP 8593E, HP 8595E, and HP 8596E spectrum analyzers only.

Peaks the YTF preselector by manually adjusting the YTF fine-tune DAC. The front-panel entry range for the DAC is from 1 to 3840.

The analyzer firmware adds the entered value to an 8-bit value (0 to 255), yielding a result between 1 and 4095. This result then drives the 12-bit YTF fine-tune DAC.

Be sure to use either **PRESET** or **PRESEL DEFAULT** to set the **PRESEL DAC** to an initial value of 2048.

**RELATED SOFTKEYS** **CAL YTF**

**PRESEL DEFAULT**

---

## QP DET ON OFF Quasi-Peak Detector On/Off

**DESCRIPTION** Note that this function is available for HP 8590 E-Series spectrum analyzers, HP 8591C cable TV analyzers, and HP 8594Q QAM analyzers only.

**QP DET ON OFF** turns the quasi-peak detector on or off.

**RELATED SOFTKEYS** **QP GAIN ON OFF**

**QP RST ON OFF**

**QPD OFFSET**

---

## QP GAIN ON OFF Quasi-Peak GAIN On/Off

**DESCRIPTION** Note that this function is available for HP 8590 E-Series spectrum analyzers, HP 8591C cable TV analyzers, and HP 8594Q QAM analyzers only.

**QP GAIN ON OFF** amplifies the video signal ten times (20 dB).

Note that the reference level offset is not changed. The marker readout and reference level readout must be divided by 10 to obtain the correct amplitude readout.

**RELATED SOFTKEYS** **QP DET ON OFF**

**QP RST ON OFF**

**QPD OFFSET**

---

## **QPD OFFSET Quasi-Peak Detector Offset**

DESCRIPTION	Sets the offset of the quasi-peak detector.  Note that this function is available for HP 8590 E-Series spectrum analyzers, HP 8591C cable TV analyzers, and HP 8594Q QAM analyzers only.  For accurate quasi-peak measurements, <b>QPD OFFSET</b> should be set to a value of 29. The quasi-peak detector offset is set to a value of 29 by pressing <b>PRESET</b> .
RELATED SOFTKEYS	<b>QP DET ON OFF</b>  <b>QP GAIN ON OFF</b>  <b>QPD RST ON OFF</b>

---

## **QPD RST ON OFF Quasi-Peak Detector Reset On/Off**

DESCRIPTION	Note that this function is available for HP 8590 E-Series spectrum analyzers, HP 8591C cable TV analyzers, and HP 8594Q QAM analyzers only.  <b>QPD RST ON OFF</b> discharges and resets the quasi-peak detector.
RELATED SOFTKEYS	<b>QP DET ON OFF</b>  <b>QP GAIN ON OFF</b>  <b>QPD OFFSET</b>

---

## **SERVICE CAL Service Calibration**

DESCRIPTION	Provides access to the service-softkey functions.
RELATED SOFTKEYS	Refer to Figure 13-1 and Figure 13-2.

---

## **SERVICE DIAG Service Diagnostics**

DESCRIPTION	Provides access to the service-diagnostic softkey functions. For selected service softkeys, an abbreviation for the active service function appears in the detector display block. The display block is located in the upper left-hand corner of the display.
RELATED SOFTKEYS	Refer to Figure 13-1 and Figure 13-2.

---

## SET ATTN ERROR Set Attenuator Error

### DESCRIPTION

Note that to avoid losing correction-constant data, make a backup copy of all correction data before servicing the analyzer.

Refer to **DISPLAY CAL DATA** and **EDIT FLATNESS** for the location of the correction data.

The step attenuators on the A12 amplitude control assembly are the relative amplitude reference for the **CAL AMPTD** routine. Four of the five step attenuators (the 1 dB, 2 dB, 4 dB, and 8 dB steps) are used. Currently, the 16 dB attenuator step is not used.

If the factory-loaded attenuator-correction constants are no longer valid, new attenuator-correction constants must be developed for the following circumstances.

- A new A12 amplitude control assembly is installed.
- A new A16 processor/video assembly is installed.
- The battery-backed nonvolatile memory contains errors caused by any one of the following.
  - A dead BT101 battery.
  - Correction data accidentally altered by the user after he has entered the passcode and gained access to the **SERVICE CAL** softkeys.
  - Defective hardware on the A16 assembly.

Refer to “6. Cal Attenuator Error” in Chapter 2 to characterize the four attenuator steps and produce new attenuator correction constants.

Enter the new correction constants into A16 RAM with the following procedure.

1. Press the following keys.

**PRESET**

**FREQUENCY** -2001 **Hz**

**SET ATTN ERROR**

2. The data-entry instruction for the 1 dB step, **ENTER CAL ATTEN ERROR 1**, is displayed in the active-function block, just below the active entry for the reference-level-offset value, **REF LVL OFFSET**.
3. Enter the characterization data for the 1 dB, 2 dB, 4 dB, and 8 dB steps, with a 0.01 dB resolution for each entry.
4. Terminate each entry with either the **+dBm** or **-dBm** key.

5. Enter the original factory value, or a default value of 0 dBm, for the 16 dB step.

After each entry the characterized value is displayed, with 0.1 dB resolution, to the left of the graticule, followed by the offset-reference-level indicator, OFFSET.

If desired, use **DISPLAY CAL DATA** to review the new attenuator-characterization data with 0.01 dB resolution. Refer to **DISPLAY CAL DATA** for an explanation of the displayed calibration data.

RELATED SOFTKEYS

**CAL AMPTD**

**DISPLAY CAL DATA**

---

## **STOR PWR ON UNITS Store Power-On Units**

DESCRIPTION

Allows the user to change the amplitude display units that appear at instrument power-on or when **PRESET** is pressed. The following amplitude display units can be selected: dBm, dBmV, dB $\mu$ V, Volts, and Watts. For example, pressing the following keys sets the analyzer power-on units to read out in dBmV in log mode, volts in linear mode, and input impedance to 50 or 75 ohms.

**PRESET**

**FREQUENCY** -2001 **Hz**

**AMPLITUDE** MORE 1 of 2 **INPUT Z (50) or (75)**

**AMPLITUDE** SCALE LOG LIN (LOG) MORE 1 of 2 **AMPTD UNITS dBmV**

**AMPLITUDE** SCALE LOG LIN (LIN) MORE 1 of 2 **AMPTD UNITS Volts**

**CAL** MORE 1 of 3 MORE 2 of 3 **SERVICE CAL STOR PWR ON UNITS**

Note that selecting **INPUT Z (50)** ensures that the analyzer will make amplitude calculations based on a 50 $\Omega$  system. Select **INPUT Z (75)** for instruments equipped with 75 $\Omega$  input. Changing **INPUT Z** does not affect the input impedance of the analyzer.

To return the analyzer to the standard power-on settings, use the procedures in "Analyzer Initialization" in Chapter 3 of this service guide.

---

## STORE FLATNESS Store Flatness

**DESCRIPTION** Note that the **STORE FLATNESS** softkey is accessible only after entering the –2001 Hz passcode prior to pressing the **CAL** and **EDIT FLATNESS** softkeys.

After entering new flatness-correction constants, use **STORE FLATNESS** to store them in nonvolatile memory.

---

**Caution** Avoid pressing the **INIT FLT** softkey when pressing the **STORE FLATNESS** softkey. All the flatness-correction constants will be lost if **INIT FLT** is pressed accidentally.

---

**RELATED SOFTKEYS** **EDIT FLATNESS**

---

## STP GAIN ZERO Step-Gain Zero

**DESCRIPTION** Disables the two 20-dB step-gain amplifiers on the A12 amplitude control assembly. While disabled, the A12 assembly provides the same gain for all reference-level settings of –10 dBm and below.

The two amplifiers are disabled as part of the A14 Log Amplifier adjustment procedure in Chapter 2. Use **PRESET** to reset the step-gain amplifiers.

---

## SWEEP RAMP Sweep Ramp

**DESCRIPTION** Displays the **RAMP** signal from the Sweep-Ramp Generator on the A7 analog interface assembly. The **RAMP** signal has a range of –10 V to +10 V. A positive-going ramp extending from the lower-left corner of the screen to the upper-right corner represents a normal **RAMP** signal.

Refer to Chapter 6 for additional LO troubleshooting information.

---

## **SWEEP TIME DAC Sweep-Time DAC**

**DESCRIPTION** Displays the output of the sweep-time DAC, SWP\_DAC, from the sweep-ramp generator on the A7 analog interface assembly. The top graticule represents +10 V and the bottom represents –10 V.

The sweep times are grouped into three ranges.

- 20 milliseconds to less than 300 milliseconds.
- 300 milliseconds to less than 6 seconds.
- 6 seconds to 100 seconds.

Within each range, a negative voltage is displayed and becomes more negative as the sweep time is decreased.

Refer to Chapter 4 for additional troubleshooting information.

**RELATED SOFTKEYS** **SWEEP RAMP**

---

## **VERIFY TIMEBASE Verify Timebase**

**DESCRIPTION** Note that instruments equipped with Precision Frequency Reference do not use this softkey function.

Allows the DAC value for the 10 MHz timebase to be changed temporarily. Either the –37 Hz or the –2001 Hz passcode must be entered to activate this function.

This function is used to verify the settability specification for the timebase. Refer to the 10 MHz reference accuracy verification test in the calibration guide for your instrument.

**RELATED SOFTKEYS** **CAL TIMEBASE**

---

## X FINE TUNE DAC Extra-Fine Tune DAC

**DESCRIPTION** Displays the output of the YTO extra-fine-tune DAC, FM\_TUNE, on the A7 analog interface assembly.

The lower four divisions of the screen represent a 0 to –10 V output range. Midscreen represents 0 V and bottom-screen represents –10 V. The DAC voltage level is displayed as a horizontal line within the four divisions.

Refer to Chapter 6 for additional LO troubleshooting information.

**RELATED SOFTKEYS**    **COARSE TUNE DAC**  
**FINE TUNE DAC**  
**DACS**

---

## YTF DRIVER YTF Driver

**DESCRIPTION** Note that this function is available for HP 8592L, HP 8593E, HP 8595E, and HP 8596E spectrum analyzers only.

Displays the output of the sample-and-hold circuit in the YTF span divider and driver on the A7 analog interface assembly. This signal is then converted to a current to drive the YTF.

The instrument must be in a single-band sweep for the display to be valid.

The lower four divisions of the screen represent a 0 to –10 V output range. Midscreen represents 0 V and bottom-screen represents –10 V.

A ramp is displayed for all spans except zero span. In zero span, a horizontal line is displayed.

The displayed voltage is the sum of the YTF fine-tune DAC, YTF coarse-tune DAC, and YTF span voltages. The voltage becomes more negative as the tuned frequency increases.

Refer to Chapter 6 for further troubleshooting information.

**RELATED SOFTKEYS**    **YTF TUNE COARSE**  
**YTF TUNE FINE**  
**YTF SPAN**



---

## YTF TUNE COARSE YTF Tune Coarse

DESCRIPTION	<p>Note that this function is available for HP 8592L, HP 8593E, HP 8595E, and HP 8596E spectrum analyzers only.</p> <p>Displays the output of the YTF coarse-tune DAC produced on the A7 analog interface assembly.</p> <p>The instrument must be in a single-band sweep for the display to be valid.</p> <p>The lower four divisions of the screen represent a 0 to –10 V output range. Midscreen represents 0 V and bottom-screen represents –10 V.</p> <p>The DAC voltage level is displayed as a horizontal line within the four lower divisions. The voltage becomes more negative as the center frequency is increased. Refer to Chapter 6 for further troubleshooting information.</p>
RELATED SOFTKEYS	<p>YTF TUNE FINE</p> <p>YTF DRIVER</p> <p>YTF SPAN</p>

---

## YTF TUNE FINE YTF Tune Fine

DESCRIPTION	<p>Note that this function is available for HP 8592L, HP 8593E, HP 8595E, and HP 8596E spectrum analyzers only.</p> <p>Displays the output of the YTF fine-tune DAC on the Analog Interface assembly. This DAC voltage provides only fine adjustment of the YTF tuning; there is no direct correlation between the DAC voltage and the center-frequency setting.</p> <p>The instrument must be in a single-band sweep for the display to be valid.</p> <p>The lower four divisions of the screen represent a 0 to –10 V output range. Midscreen represents 0 V and bottom-screen represents –10 V.</p> <p>The DAC voltage level is displayed as a horizontal line within the four lower divisions.</p> <p>Refer Chapter 6 for further troubleshooting information.</p>
RELATED SOFTKEYS	<p>YTF TUNE COARSE</p> <p>PRESEL DAC</p> <p>PRESEL DEFAULT</p>

---

## YTF SPAN YTF Span

### DESCRIPTION

Note that this function is available for HP 8592L, HP 8593E, HP 8595E, and HP 8596E spectrum analyzers only.

Displays the output of the YTF span divider, YTF\_SPAN, on the A7 analog interface assembly.

The analyzer must be in a single-band sweep for the display to be valid. The swept range of the A3A8 YTF cannot exceed 7 GHz.

Perform the following steps to observe YTF\_SPAN.

1. Press **SPAN** before pressing **CAL**.
2. Press **YTF SPAN** to display a negative-going ramp, centered about the center horizontal graticule.
3. Adjust the span setting while observing the displayed ramp. The slope of the ramp increases as the span is increased.
4. Press **YTF SPAN** after each change in span setting.

For spans of less than 200 MHz, the display appears flat, due to quantization errors.

Refer to Chapter 6 for further troubleshooting information.

### RELATED SOFTKEYS

**YTF TUNE COARSE**

**YTF TUNE FINE**

**YTF DRIVER**

## Analyzer Messages

---

Refer to this chapter for information about hardware-error, user-error, and informational messages that are displayed when a problem with the operation of the analyzer occurs.

---

### Interpreting Analyzer Messages

The analyzer firmware displays error messages and informational prompts to warn the user of instrument failure or improper use.

There are three types of messages: hardware-error messages (H), informational messages (M), and user-created error messages (U).

- Hardware-error messages indicate that the firmware has detected a fault in the analyzer hardware.
- Informational messages provide prompts or messages to inform the user of the analyzer status during a specific routine.
- User-created error messages indicate the analyzer is being used incorrectly. They are usually generated during remote operation.

---

### What's in This Chapter

Each analyzer message is listed in alphabetical order. The following information is provided, where applicable:

- The message type, identified by an H, M, or U.
- An operational definition for each analyzer message.
- The related analyzer assembly, or assemblies, that is the likely cause of the problem defined by the hardware-error message.
- Relevant troubleshooting hints.

## $\phi$ LOCK OFF (U) (H)

Indicates slow YTO tuning. This message may appear if the analyzer is using default correction factors.  $\phi$  LOCK OFF appears briefly during the CAL FREQ routine, during instrument preset, or when the frequency value is changed; this is normal and does not indicate a problem.

### Related Assemblies

A6 YTO, A9 third converter, A25 counter lock.

### Troubleshooting Hints

If this message appears constantly, perform the CAL FREQ routine to try to eliminate this message.

## ADC-GND FAIL (H)

During an instrument preset, the analog-to-digital converter reading for ground on the A16 processor/video assembly is outside the test limit. An instrument preset routine is also performed during the self-calibration routines.

### Related Assemblies

A7 analog interface, A8 power supply, A15 motherboard, A16 processor/video assembly, assemblies installed in the card cage.

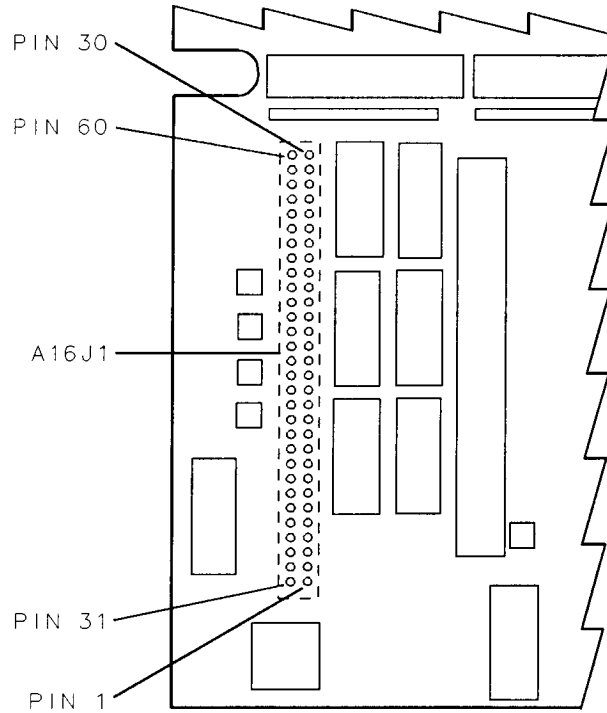
### Troubleshooting Hints

The +15 V and –15 V supplies from the A8 power supply can cause this error message. If the power-supply LEDs for both power supplies are on, check that the supplies are within tolerance using the test points on the A16 processor/video assembly.

A voltage greater than +10 Vdc on pins 1, 3, 5, 7, or 31 of A16J1 can cause this error message. Refer to Figure 14-1 for the numbering order of the A16J1 connector pins that are accessible from the component side of the A16 assembly. If a voltage greater than +10 V is present on any one of the A16J1 pins indicated, use Table 14-1 to locate the source of the error message.

**Table 14-1. Possible Cause of the Error Message ADC-GND FAIL**

<b>A16J1 Pin Number</b>	<b>Possible Error-Message Source</b>
1	A14 log amplifier assembly An assembly installed in the card cage
3	An assembly installed in the card cage
5	An assembly installed in the card cage
7	A16 processor/video assembly An assembly installed in the card cage Signal incorrectly applied to the AUX VIDEO output
31	A7 analog interface



sh238e

**Figure 14-1. A16J1 Connector-Pin Orientation**

Before removing the A16 processor/video assembly, check all assemblies that are identified in Table 14-1.

1. Turn the instrument power off and remove each assembly, one at a time.
2. Turn the instrument on.
  - If the ADC ground fault remains, the instrument preset at power-up displays the error message.
  - If the error message goes away, the last assembly removed is the cause of the problem.
  - If the error message remains after the removal of all related assemblies, suspect the A16 processor/video assembly.

An ADC ground failure can also be checked manually, using the service diagnostic. Press **CAL**, More 1 of 4, More 2 of 4, Service Diag, More 1, GND REF DETECTOR.

## ADC-TIME FAIL (H)

During an instrument preset, the time between analog-to-digital conversion readings is greater than the test limit. An instrument preset routine is also performed during the self-calibration routines.

### Related Assemblies

A16 processor/video assembly.

### Troubleshooting Hints

If the instrument does not sweep, and all other instrument functions are normal, the probable cause of the error message is a defective A16 processor/video assembly.

## ADC-2V FAIL (H)

During an instrument preset, the analog-to-digital converter reading for the +2 V reference on the A16 processor/video assembly is outside the test limit. An instrument preset routine is also performed during the self-calibration routines.

### Related Assemblies

A8 power supply, A15 motherboard, A16 processor/video assembly, assemblies installed in the card cage.

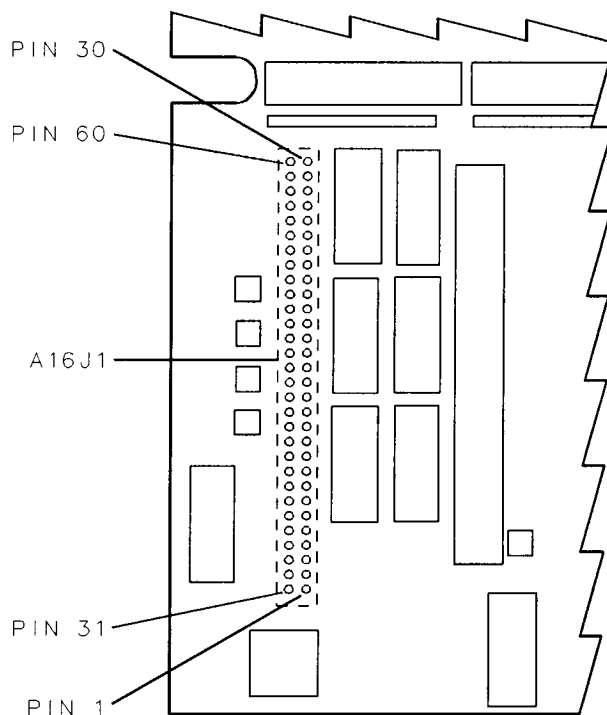
### Troubleshooting Hints

The +15 V and –15 V supplies from the A8 power supply can cause this problem. If the power-supply LEDs for both supplies are on, check that the supplies are within tolerance using the test points on the A16 processor/video assembly.

A voltage greater than +10 Vdc on pins 1, 3, 5, 7, or 31 of A16J1 can cause this error message. Refer to Figure 14-2 for the numbering order of the A16J1 connector pins that are accessible from the component side of the A16 assembly. If a voltage greater than +10 V is present on any one of the A16J1 pins indicated, use Table 14-2 to locate the source of the error message.

**Table 14-2. Possible Cause of the Error Message ADC-2V FAIL**

<b>A16J1 Pin Number</b>	<b>Possible Error-Message Source</b>
1	A14 log amplifier assembly An assembly installed in the card cage
3	An assembly installed in the card cage
5	An assembly installed in the card cage
7	A16 processor/video assembly An assembly installed in the card cage Signal incorrectly applied to the AUX VIDEO output
31	A7 analog interface assembly



sh238e

**Figure 14-2. A16J1 Connector-Pin Orientation**

Before removing the A16 processor/video assembly, check all assemblies that are identified in Table 14-2.

1. Turn the instrument power off and remove each assembly, one at a time.
2. Turn the instrument on.
  - If the ADC 2 V fault remains, the instrument preset at power-up displays the error message.
  - If the error message goes away, the last assembly removed is the cause of the problem.
  - If the error message remains after the removal of all related assemblies, suspect the A16 processor/video assembly.

Check the ADC 2 V reference voltage on the A16 processor/video assembly. Refer to *HP 8590 Series Analyzers Component-Level Repair Service Guide* for the location of the 2 V reference circuit in the analog-to-digital function block.

A 2 V reference failure can also be checked manually, using the service diagnostics. Press **CAL**, **More 1 of 4**, **More 2 of 4**, **Service Diag**, **More 1**, **2v REF DETECTOR**.

### **CAL: \_ \_ \_ (M)**

During the self-calibration routine, messages may appear on the display to indicate how the calibration routines are progressing. For example, sweep, freq, span, MC delay, FM coil, and atten can appear on the analyzer display.

Please note that it is normal for the  $\phi$  LOCK OFF and REF UNLOCK error messages to appear briefly during CAL FREQ.

#### **Troubleshooting Hints**

If the firmware detects a problem during the self-calibration routine, the routine will stop and display an error message (H). Refer to the appropriate error-message description in this section.

### **CAL: \_ \_ \_ : done Press CAL STORE to save (M)**

Indicates that the self-calibration routine is finished and that you should press CAL STORE.

### **CAL: cannot execute CALAMP enter: 0 dB PREAMP GAIN (U)(H)**

The preamplifier gain is not set to 0 dB. The preamplifier gain must be set to 0 dB for the CAL AMPTD routine to be performed.

#### **Troubleshooting Hints**

Reset the preamplifier gain to 0 dB using the following routines.

1. Press **AMPLITUDE**, **More 1 of 3**, **EXTERNAL PREAMPG** and set the preamplifier gain to 0 dB.
2. Perform the CAL AMPTD routine.
3. Press CAL STORE to store the new calibration factors and the preamplifier setting of 0 dB.

Please note that pressing **PRESET** does not initialize the preamp-gain setting to 0 dB.

If this message is still displayed after resetting the preamp gain, it is likely there is a failure in RAM on the A16 processor/video assembly.



## **CAL: DATA NOT STORED CAL AMP NEEDED (U)(H)**

The current correction-factor data is the default calibration data. The instrument firmware prevents the default data from being stored. While the default data is in use, a flag is set. If **CAL STORE** is pressed, the error message is displayed and **CAL STORE** is disabled. Successful completion of the **CAL AMPTD** routine clears the flag.

### **Related Assemblies**

A16 processor/video assembly

### **Troubleshooting Hints**

Perform the **CAL FREQ** and **CAL AMPTD**. For HP 8592L, 8593E, 8595E, and 8596E spectrum analyzers, also perform the **CAL YTF** routine. If the error message reappears after pressing **CAL STORE**, the **CAL AMPTD** routine was not successfully completed.

Pressing **CAL FETCH** also clears the correction-data error flag and can permit erroneous data to be stored. Use **CAL FETCH** only for troubleshooting.

## **CAL: FM SPAN SENS FAIL (H)**

During the **CAL FREQ** self-calibration routine, the analyzer cannot set the span sensitivity of the FM coil. The output of the fine-tune DAC, located on the A7 analog interface assembly, is changed to move the displayed signal four divisions. If the signal does not move to within  $\pm 1.25$  divisions of the expected display position, the error message is displayed.

### **Related Assemblies**

HP 8590L and HP 8591E spectrum analyzers only:  
A6 YTO, A7 analog interface.

All other HP 8590 E-Series and L-Series spectrum analyzers:  
A3A7 YTO, A7 analog interface.

### **Troubleshooting Hints**

Perform the **CAL FREQ** routine again.

## **CAL: GAIN FAIL (H)**

During the CAL AMPTD routine, the amplitude of the video signal at the ADC on the A16 processor/video assembly is too low. The error message appears when the reference-level-calibration DAC, located on the A7 analog interface assembly, has been adjusted to its maximum of 255, and the amplitude of the video signal remains below tolerance.

### **Related Assemblies**

HP 8590L and HP 8591E spectrum analyzers only:

A3 input attenuator, A4 first converter, A5 second converter, A6 YTO, A7 analog interface, A9 third converter, A11 bandwidth filter, A12 amplitude control, A13 bandwidth filter, A14 log amplifier.

All other HP 8590 E-Series and L-Series spectrum analyzers:

A3 front end, A7 analog interface, A9 third converter, A11 bandwidth filter, A12 amplitude control, A13 bandwidth filter, A14 log amplifier.

### **Troubleshooting Hints**

The CAL AMPTD routine checks the amplitude of the video signal as it adjusts the A7 reference-level-calibration DAC. Normally, the video-signal amplitude should move within tolerance as the A7 DAC changes the gain of the IF calibration amplifier on the A9 third converter assembly. Refer to Foldout 9-1, IF/Control Overall Block Diagram, and Foldout 9-2, 9-3, or 9-4, RF Section Overall Block Diagram for your analyzer, for more information.

Check the signal amplitude along the signal path from the RF input, through the IF section, to the output of the A14 log amplifier. Refer to "Isolating an RF, LO, IF, or Video Problem" in Chapter 4 for further troubleshooting information.

## **Cal harmonic > = 5.7 GHz NOT found (U)(H)**

Indicates that the CAL YTF routine for an HP 8595E cannot find a harmonic of the 300 MHz calibration signal.

### **Related Assemblies**

A9 third converter.

### **Troubleshooting Hints**

Ensure that the CAL OUT connector is connected to the analyzer input, perform the CAL FREQ & AMPTD routine, and then perform the CAL YTF routine again.

### **CAL: MAIN COIL SENSE FAIL (H)**

The analyzer could not set up span sensitivity of the main coil.

#### **Related Assemblies**

HP 8590L and HP 8591E spectrum analyzers only:  
A6 YTO, A7 analog interface.

All other HP 8590 E-Series and L-Series spectrum analyzers:  
A3A7 YTO, A7 analog interface.

#### **Troubleshooting Hints**

If this message appears, press **FREQUENCY**, **-37**, **Hz**, **CAL**, **More 1 of 4**, **More 2 of 4**, **DEFAULT CAL DATA**, and perform the CAL FREQ routine again.

### **CAL: NBW 200 Hz notch amp failed (H)**

Indicates that the 200 Hz resolution bandwidth is not the correct shape for the calibration routine.

#### **Related Assemblies**

A130 narrow resolution bandwidth card.

#### **Troubleshooting Hints**

Perform the **CAL AMPTD**.

### **CAL: NBW 200 Hz notch failed (H)**

Indicates that the 200 Hz resolution bandwidth is not the correct shape for the calibration routine.

#### **Related Assemblies**

A130 narrow resolution bandwidth card.

#### **Troubleshooting Hints**

Perform the **CAL AMPTD**.

### **CAL: NBW 200 Hz width failed (H)**

Indicates that the 200 Hz resolution bandwidth is not the correct bandwidth for the calibration routine.

#### **Related Assemblies**

A130 narrow resolution bandwidth card.

#### **Troubleshooting Hints**

Perform the `CAL AMPTD`.

### **CAL: NBW gain failed (H)**

Indicates that one of the resolution bandwidths is not the correct amplitude for the calibration routine.

#### **Related Assemblies**

A130 narrow resolution bandwidth card.

#### **Troubleshooting Hints**

Perform the `CAL AMPTD`.

### **CAL: NBW width failed (H)**

Indicates that one of the resolution bandwidths is not the correct width for the calibration routine.

#### **Related Assemblies**

A130 narrow resolution bandwidth card.

#### **Troubleshooting Hints**

Perform the `CAL AMPTD`.

### **CAL: PASSCODE NEEDED (M)**

The service function executed cannot be performed without the service passcode.

#### **Troubleshooting Hints**

Before performing any function that requires a service passcode, be sure you understand the consequences of the function. Improper use of functions that require a passcode can delete factory correction constants that are difficult to replace.

Refer to the passcode information in Chapter 13 for information about the proper use of the passcodes.

## CAL: RES BW AMPL FAIL (H)

During the **CAL AMPTD** routine, the insertion loss of a resolution bandwidth filter, relative to the amplitude of the 3 kHz resolution bandwidth filter, was greater than 2.2 dB.

### Related Assemblies

A7 analog interface, A11 bandwidth filter, A13 bandwidth filter, A14 log amplifier/detector.

### Troubleshooting Hints

The **CAL AMPTD** routine will stop at the resolution bandwidth that failed. If the A11/A13 bandwidth filter assemblies require realignment, use the crystal and LC bandwidth filter adjustment procedures in Chapter 2.

If a defective bandwidth filter board is suspected, refer to “IF Power-Level Measurement” in Chapter 5.

## CAL SIGNAL NOT FOUND (U)(H)

During a self-calibration routine, the CAL OUT signal cannot be found. The primary purpose of the CAL OUT check is to confirm that CAL OUT is connected to the input. A CAL OUT signal that is not within 300 MHz  $\pm$ 50 MHz, or is not greater than or equal to  $-45$  dBm, causes this error message to be displayed.

### Related Assemblies

A7 analog interface, A9 third converter.

### Troubleshooting Hints

If one of the following conditions are present, the error message is displayed.

- The CAL OUT signal is missing. Ensure that the CAL OUT is connected to the input connector using the CAL OUT cable supplied with the analyzer.

Refer to Table 1-4 for the part number of the CAL OUT cable.

If the calibration cable is connected properly, manually check the CAL OUT signal.

- The CAL OUT signal is not within  $\pm$ 50 MHz of 300 MHz, or it has an amplitude less than or equal to  $-45$  dBm. The test limits are large enough to indicate an obvious failure for either the CAL OUT signal or the analyzer.
- The **DEFAULT CAL DATA** is in use and the frequency of the CAL OUT signal appears out of tolerance.

The default data introduces frequency offsets that can make an accurate CAL OUT signal appear to be outside the test limits for the CAL OUT check. If desired, the instrument CAL OUT check can be bypassed. Enter the  $-37$  Hz passcode before pressing **CAL** and the desired self-calibration softkey.

Refer to the description of **DEFAULT CAL DATA** in Chapter 13 for additional information.

- The analyzer has extremely low gain. Refer to “Isolating an RF, LO, IF, or Video Problem” in Chapter 4.

Be sure to perform all internal self-calibration routines after resolving the calibration signal problem. Refer to the calibration guide for your instrument.

## **CAL: SPAN SENS FAIL (H)**

During the CAL FREQ self-calibration routine the main-coil span-sensitivity adjustment routine has failed, indicating that the spans controlled by the main coil (LO spans greater than 10 MHz) are not working correctly. The span-sensitivity adjustment routine checks for three displayed signals: 0 Hz, 300 MHz, and 600 MHz. If three signals are not found in a 750 MHz span, the error message is displayed.

### **Related Assemblies**

HP 8590L and HP 8591E spectrum analyzers only:  
A6 YTO, A7 analog interface, A9 third converter, A16 processor/video assembly.

All other HP 8590 E-Series and L-Series spectrum analyzers:  
A3A7 YTO, A7 analog interface, A9 third converter, A16 processor/video assembly.

### **Troubleshooting Hints**

Spurious signals can cause this routine to fail.

Refer to the MAIN SPAN softkey description for further information in Chapter 13.

## **CAL: USING DEFAULT DATA (M)**

The CAL AMPTD routine was not completed and default correction factors are being used.

### **Troubleshooting Hints**

Interruption of the CAL AMPTD routine can cause the routine to terminate and produce this message.

Refer to Chapter 13 for more information about DEFAULT CAL DATA.

## **CAL YTF FAILED (U)(H)**

Indicates that the CAL YTF routine could not be successfully completed.

### **Related Assemblies**

HP 8592L and HP 8593E model analyzers only:  
A3A2 microwave switch, A3A8 YIG-tuned filter, A7 analog interface assembly.

All other HP 8590 E-Series spectrum analyzers and HP 8591C cable TV analyzers: (*except HP 8594E and HP 8594Q*)  
A3A8 switched YIG-tuned filter, A7 analog interface assembly.

### **Troubleshooting Hints**

If this message appears, ensure that the CAL OUT connector (for the HP 8595E) or 100 MHz COMB OUT connector (for the HP 8592L, HP 8593E, or HP 8596E) is connected to the analyzer input, perform the CAL FREQ & AMPTD routine, and then perform the CAL YTF routine again.

## **CAL: ZERO FAIL (H)**

The analyzer could not set up the tuning sensitivity of the main coil.

### **Related Assemblies**

HP 8590L and HP 8591E spectrum analyzers only:  
A6 YTO, A7 analog interface assembly.

All other HP 8590 E-Series and L-Series spectrum analyzers:  
A3A7 YTO, A7 analog interface assembly.

### **Troubleshooting Hints**

If this message appears, press **FREQUENCY**, **-37**, **Hz**, **CAL**, **More 1 of 4**, **More 2 of 4**, **DEFAULT CAL DATA**, and perform the CAL FREQ routine again.

## **Cannot engage phase lock with current CAL FREQ data (U)**

Indicates that the CAL FREQ routine needs to be performed before phase locking can be turned on.

### **Related Assemblies**

A9 third converter assembly.

### **Troubleshooting Hints**

If this message appears, press **FREQUENCY**, **-37**, **Hz**, **CAL**, **More 1 of 4**, **More 2 of 4**, **DEFAULT CAL DATA**, and perform the CAL FREQ routine again.

## **Cannot reach N dB points (U)**

Indicates that the number of dB specified for the N dB PTS function is greater than the distance of the signal peak from the analyzer noise floor or peak threshold.

### **Related Assemblies**

A9 third converter, A16 processor/video assembly.

### **Troubleshooting Hints**

Access the detector by pressing **TRACE**, **More 1 of 3**, **DETECTOR SMP PK**. Toggle between **SAMPLE** and **PEAK** detector while looking for a difference in trace amplitude. If there appears to be a drastic difference in amplitude, the problem lies in the **PEAK** detector section of the A16 processor/video assembly.

### **Check trigger input (U)**

Indicates that the analyzer needs an external trigger signal to use the time-gating functions.

#### **Related Assemblies**

A16 processor/video assembly, A105 gated video board assembly.

#### **Troubleshooting Hints**

Ensure there is a trigger pulse connected to the GATE TRIGGER INPUT connector on the rear panel of analyzer and that the GATE OUTPUT is connected the EXT TRIG INPUT connector.

### **Comb harmonic at \_ \_ \_ GHz NOT found (U)(H)**

Indicates that the CAL YTF routine for the analyzer cannot find a harmonic of the comb generator at frequency displayed.

#### **Related Assemblies**

HP 8590L and HP 8591E spectrum analyzers only:  
A3A8 YIG-tuned filter, A7 analog interface assembly.

All other HP 8590 E-Series and L-Series spectrum analyzers: (*except HP 8594D*)  
A3A8 switched YIG-tuned filter, A7 analog interface assembly.

#### **Troubleshooting Hints**

Ensure that the 100 MHz COMB OUT connector (for an HP 8592L, HP 8593E, or HP 8596E) or the CAL OUT connector (for an HP 8595E) is connected to the analyzer input with a low-loss, short cable before the CAL YTF routine is performed.



## COMB SIGNAL NOT FOUND (U)(H)

This message applies to HP 8592L, 8593E, 8596E model analyzers only.

During the CAL YTF self-calibration routine, the comb signal cannot be found.

### Related Assemblies

A3A1 comb generator, A3A11 step-recovery diode, A3A12 3dB attenuator, J2 comb-generator output connector.

### Troubleshooting Hints

- Make sure that the 100 MHz COMB OUT is connected to the analyzer input using the comb generator cable (SMA to Type N) supplied with the analyzer. (A comb generator cable (SMA to SMA) is supplied with Option 026 instruments.)
- Perform the following steps to verify the comb-generator output manually.

1. Press the following keys.

**PRESET**

**FREQUENCY** 100 **MHz**

**SPAN** 500 **MHz**

2. Look for the 100 MHz comb-generator signal to the right of the local oscillator signal. When COMB GEN ON OFF is OFF, this signal has an amplitude of approximately  $-8$  dBm and the 100 MHz harmonics are less than  $-20$  dBc.
3. Press the following keys.

**AUX CTRL**

**COMB GEN ON OFF** (On)

4. When the comb-generator output amplifier is enabled, the amplitude of the 100 MHz signal and the 100 MHz harmonics increase. The 100 MHz signal amplitude increases to approximately  $+12$  dBm.
  - If the signal amplitude does not increase, check that the comb-generator control line from the A7 analog interface assembly is switching correctly.  
Refer to Foldout 9-2, 9-3, or 9-4, RF Section Overall Block Diagram for your analyzer, for the comb-generator control voltage values.
  - If the A7 control line is correct, suspect the A3A11 step-recovery diode or the A3A1 comb generator.

Refer to Foldout 9-2, 9-3, or 9-4, RF Section Overall Block Diagram for your analyzer, for more information.

### **COMMAND ERROR: \_ \_ \_ (U)**

The specified programming command is not recognized by the analyzer.

#### **Related Assemblies**

A16 processor/video assembly.

#### **Troubleshooting Hints**

Refer to the *HP 8590 E-Series and L-Series Spectrum Analyzers, and HP 8591C Cable TV Analyzer Programmer's Guide* for a description of legal commands.

### **CONF TEST FAIL (U)(H)**

Indicates that the confidence test failed. If this happens, ensure that the CAL OUT connector is connected to the analyzer input, perform the CAL FREQ & AMPTD routine, and then perform the confidence test again. This message also sets SRQ 110.

#### **Troubleshooting Hints**

The confidence test routine identifies the analyzer function that failed the test. Refer to the **CONF TEST** description in Chapter 13 for more information.

### **Factory DLP, not adaptable (U)**

Indicates that the downloadable program or variable that you have selected is used by a "personality" and cannot be edited. A personality is a program that is manufactured by Hewlett-Packard and is available for use with the HP 8590 Series analyzer. An example of a personality is the HP 85716A CATV system monitor personality.

### **FAIL: XXXX XXXXXXXXXXXX (H)**

A circuit-test failure was detected by the central processing unit (CPU) during power-up or instrument preset. A failure code has two major parts: a 4-digit code followed by a 10-digit code. The 10-digit code contains three separate failure codes. Each failure code must be converted from hexadecimal to binary before it can be interpreted, using Table 14-3 through Table 14-6.

Component-level information is provided with this error message description. Refer to the *HP 8590 Series Analyzers Component-Level Repair Service Guide* binder for further information about the indicated components.

## The Four-Digit Failure Code

The four-digit failure code identifies the circuit location of the failure on the A16 processor/video assembly. Component-level failure information is also provided. Each digit of the four-digit hexadecimal segment must be translated to its binary equivalent before using Table 14-3 to locate the probable failure.

The 16 LEDs along the right-hand side of the A16 assembly provide the same error information that is contained in the 4-digit failure code. Use Table 14-3 to interpret the illuminated LEDs for an instrument failure.

Here is an example of a failure code. It is unlikely that an analyzer would have so severe a failure involving all the components indicated. The example is for demonstration only.

FAIL: DF40 0625C1F72D

The four-digit failure code (DF40) is interpreted in Table 14-3. The three fail codes within the 10-digit section (0625C1F72D) are interpreted in the "The 10-Digit Failure Code" description.

**Table 14-3. Four-Digit Failure Code Interpretation**

Digits From Example	Equivalent Binary Value	A16 LEDs	A16 Circuit Tested	A16 Reference Designator
D →	8	16	Video RAM *	U305, U306
↵	4	15	I/O Bus Address *	U18
↵	2	14	CPU	U12
↵	1	13	68230	U57
F →	8	12 <sup>†</sup>	I/O Bus (Odd byte)	U2
↵	4	11	I/O Bus (Even byte)	U3
↵	2	10	User RAM	U5
↵	1	9	User RAM	U22
4 →	8	8	User RAM	U5
	4	7	User RAM	U22
		6	NOT USED	
		5	NOT USED	
0	8	4	ROM (Odd B LSB)	U6
	4	3	ROM (Even B LSB)	U23
	2	2	ROM (Odd A LSB)	U7
	1	1	ROM (Even A LSB)	U24
<p>* Refer to the 10-digit failure code description for more information.  <sup>†</sup> LED DS12 remains on after pressing <b>PRESET</b>.</p>				

### The 10-Digit Failure Code

The 10-digit segment provides further failure information for the I/O address bus, the I/O data bus, and the A16 video RAM circuitry. Each digit of the 10-digit hexadecimal segment must be translated to its binary equivalent to obtain the failure information.

The 10-digit failure code section is divided into three separate codes. The 10-digit failure code example (0625C1F72D) is separated into three codes as shown below.

FAIL: DF40 (06) (25C1) (F72D)

Each failure code from the example is converted from hexadecimal to binary and interpreted in Table 14-4, Table 14-5, and Table 14-6.

**The I/O Address Bus Failure Code.** The first two digits of the 10-digit code identify the failed address lines on the I/O address bus. Convert the two digits to binary and interpret them with Table 14-4.

**Table 14-4. I/O Bus Address Failure-Code Interpretation**

Digits From Example	Equivalent Binary Value	A16 Circuit Tested	A16 Reference Designator
0	8	Not Used	
	4	Not Used	
	2	Not Used	
	1	Error at ADR 4	U18
6 → ↵	8	Error at ADR 3	U18
	4	Error at ADR 2	U18
	2	Error at ADR 1	U18
	1	Error at ADR 0	U18

**The I/O Data-Bus Failure Code.** The next four digits identify failed data lines on the I/O data bus. Convert the four digits to binary and interpret them with Table 14-5.

**Table 14-5. I/O Data Bus Failure Code Interpretation**

Digits From Example	Equivalent Binary Value	A16 Circuit Tested	A16 Reference Designator
2 →	8	Error at IOB 15	U3
	4	Error at IOB 14	U3
	2	Error at IOB 13	U3
	1	Error at IOB 12	U3
5 → ↵	8	Error at IOB 11	U3
	4	Error at IOB 10	U3
	2	Error at IOB 9	U3
	1	Error at IOB 8	U3
C → ↵	8	Error at IOB 7	U2
	4	Error at IOB 6	U2
	2	Error at IOB 5	U2
	1	Error at IOB 4	U2
1 →	8	Error at IOB 3	U2
	4	Error at IOB 2	U2
	2	Error at IOB 1	U2
	1	Error at IOB 0	U2

**The Video RAM Failure Code.** The last four digits identify the failure address for the video RAM on the A16 assembly. A video RAM failure code indicates an internal failure on the A16 assembly; the section of the video RAM circuitry that is tested is not connected to other instrument assemblies. Convert the four digits to binary and interpret them with Table 14-6.

**Table 14-6. A16 Video Ram Address Failure Code Interpretation**

Digits From Example	Equivalent Binary Value	A16 Circuit Tested	A16 Reference Designator
F →	8	Error at MAD 15 *	U306
↳	4	Error at MAD 14	U305
↳	2	Error at MAD 13	U306
↳	1	Error at MAD 12	U305
7 →	8	Error at MAD 11	U306
↳	4	Error at MAD 10	U305
↳	2	Error at MAD 9	U306
↳	1	Error at MAD 8	U305
2 →	8	Error at MAD 7	U306
	4	Error at MAD 6	U305
	2	Error at MAD 5	U306
	1	Error at MAD 4	U305
D →	8	Error at MAD 3	U306
↳	4	Error at MAD 2	U305
	2	Error at MAD 1	U306
↳	1	Error at MAD 0	U305
* The acronym <i>MAD</i> stands for "Multiplexed Address and Data." There are no separate address and data lines within the A16 video RAM circuitry.			

### Related Assemblies

A7 analog interface, A16 processor/video assembly, A17 memory card, A25 counter lock, assemblies installed in the card cage.

### Troubleshooting Hints

Refer to Foldout 9-1, IF/Control Overall Block Diagram, and Foldout 9-2, 9-3, or 9-4, RF Section Overall Block Diagram for your analyzer, in Chapter 9 for an overview of the assemblies attached to the I/O bus. Refer also to "Troubleshooting the A15 Motherboard Assembly" in Chapter 5 for the location of specific I/O signal traces on related assemblies.

- If a failure code for an I/O bus address or data line occurs, remove the related assemblies one at a time until the failure message disappears. Be sure to turn the analyzer power off while removing and installing each assembly.
  - If the failure message disappears, suspect the assembly that was removed last.
  - If the failure message remains after all related assemblies have been removed, suspect the A16 assembly.
- If a A16 video RAM fail code occurs, the A16 assembly is defective.

## **File type incompatible (U)**

Indicates that the selected file is not a display image file. The file name for a display image file is always preceded by an "i."

## **FREQ UNCAL (U) (H)**

The YTO (YIG-tuned oscillator) frequency is more than 20 MHz from the desired frequency. If the FREQ UNCAL message appears constantly, it indicates a YTO-tuning error and the CAL FREQ routine should be performed. FREQ UNCAL appears briefly during the CAL FREQ routine; this is normal and does not indicate a problem. (U) and (H)

### **Related Assemblies**

HP 8590L and HP 8591E spectrum analyzers only:  
A6 YTO, A7 analog interface, A25 counter lock.

All other HP 8590 E-Series and L-Series spectrum analyzers:  
A3A7 YTO, A7 analog interface, A25 counter lock.

### **Troubleshooting Hints**

- This error message may occur when using correction data from **DEFAULT CAL DATA**. Refer to the **DEFAULT CAL DATA** description in Chapter 13 for more information.

If **DEFAULT CAL DATA** is in use, the instrument self-calibration routines must be run. Refer to the calibration guide for your instrument.

- The error message may occur if incomplete frequency calibration factors are used. Interrupting the **CAL FREQ** self-calibration routine produces incomplete frequency calibration data.

Performing the **CAL FREQ** routine may eliminate the problem. Be sure to press **CAL STORE** to store the correction factors produced by **CAL FREQ**.

- The error message may occur if either the reference oscillator or the sampling oscillator on the A25 assembly is unlocked.

Refer to "Isolating an RF, LO, IF, or Video Problem" in Chapter 4 for further information.

## **Function not available in current Mode (U)**

Indicates that the function that you have selected can only be used with the spectrum analyzer mode. You can use the **(MODE)** key to select the spectrum analyzer mode.

## **Function not available with analog display (U)**

Indicates that the function that you have selected is not compatible with the Analog+ display mode. To use the function, you must first turn off the Analog+ display mode with **ANALOG+ ON OFF**.

## **Gate card not calibrated (U)(H)**

This message can indicate that either the CAL AMPTD routine need to be performed before the time-gating functions can be used, or that something was connected to the GATE TRIGGER INPUT connector during the CAL AMPTD or CAL FREQ & AMPTD routines.

### **Related Assemblies**

A105 gated video board assembly.

### **Troubleshooting Hints**

If your analyzer is equipped with an Option 105, ensure that nothing is connected to the GATE TRIGGER INPUT connector when the CAL AMPTD or CAL FREQ & AMPTD routines are performed.

## **INTERNAL LOCKED (U)**

The analyzer internal trace and state registers have been locked. To unlock the trace or state registers, press SAV LOCK ON OFF so that OFF is underlined. For remote operation, use PSTATE OFF.

## **INVALID ACTDEF: \_ \_ \_ (U)**

The specified ACTDEF name is not valid. See the ACTDEF programming command.

## **INVALID AMPCOR: FREQ (U)**

For the AMPCOR command, the frequency data must be entered in increasing order. See the description for the AMPCOR programming command for more information.

## **INVALID BLOCK FORMAT: IF STATEMENT (U)**

An invalid block format appeared within the IF statement. See the description for the IF THEN ELSE ENDIF programming command for more information.

## **INVALID CARD (U)**

Indicates one of the following conditions: a card reader is not installed, the memory card is write-protected (check the position of the switch on the memory card), the memory card is a read-only memory (ROM) card, or a memory card has not been inserted. This message can also occur if remote programming commands for the memory card capability are executed with an HP 8590L or HP 8592L that does not have an Option 003.

**INVALID CARD: BAD MEDIA (U)(H)**

Indicates the formatting routine ( **FORMAT CARD** ) for the memory card could not be completed. See the description for INVALID CARD above for more information about the possible causes of this message.

**INVALID CARD: DATA ERROR (U)(H)**

Indicates the data could not be retrieved from the memory card.

**INVALID CARD: DIRECTORY (U)**

Indicates the memory card has not been formatted.

**INVALID CARD: NO CARD (U)**

Indicates a memory card has not been inserted.

**INVALID CARD: TYPE (U)**

Indicates one of the following conditions: a card reader is not installed, the memory card is write-protected (check the position of the switch on the memory card), the memory card is a read-only memory (ROM) card, or a memory card has not been inserted. This message can also occur if remote programming commands for the memory card capability are executed with an HP 8590L, HP 8592L, or HP 8594L that does not have an Option 003.

**INVALID CHECKSUM: USTATE (U)**

The user-defined state does not follow the expected format.

**INVALID COMPARE OPERATOR (U)**

An IF/THEN or REPEAT/UNTIL routine is improperly constructed. Specifically, the IF or UNTIL operands are incorrect.

**INVALID DET: FM or TV option only (U)**

Indicates that the selected detector cannot be used until the appropriate option is installed in the analyzer.

**INVALID ENTER FORMAT (U)**

The enter format is not valid. See the appropriate programming command description to determine the correct format.



**INVALID <file name> NOT FOUND (U)**

Indicates that the specified file could not be loaded into analyzer memory or purged from memory because the file name cannot be found.

**INVALID FILENAME \_ \_ \_ (U)**

Indicates the specified file name is invalid. A file name is invalid if there is no file name specified, if the first letter of the file name is not alphabetic, or if the specified file type does not match the type of file. See the description SAVRCLW or STOR programming command for more information.

**INVALID FILE: NO ROOM (U)**

Indicates that there is insufficient space available on the memory card to store the data.

**INVALID HP-IB ADRS/OPERATION (U)**

An HP-IB operation was aborted due to an incorrect address or invalid operation.

**Related Assemblies**

A16 processor/video assembly, A20 HP-IB interface board assembly.

**Troubleshooting Hints**

Check that there is only one controller (the analyzer) connected to the printer or plotter.

**INVALID HP-IB OPERATION REN TRUE (U)**

The HP-IB operation is not allowed.

**Related Assemblies**

A16 processor/video assembly, A20 HP-IB interface board assembly.

**Troubleshooting Hints**

This is usually caused by trying to print or plot when a controller is on the interface bus with the analyzer. To use the analyzer print or plot functions, you must disconnect any other controllers on the HP-IB. If you are using programming commands to print or plot, you can use an HP BASIC command instead of disconnecting the controller. Ensure the analyzer is configured properly for PRINT or PLOT, B/W or Paintjet, and the printer or plotter address is set correctly. See the *HP 8590 E-Series and L-Series Spectrum Analyzers, and HP 8591C Cable TV Analyzer Programmer's Guide* for more information.

**INVALID ITEM: \_ \_ \_ (U)**

Indicates an invalid parameter has been used in a programming command.

**INVALID KEYLBL: \_ \_ \_ (U)**

Indicates that the specified key label contains too many characters. A key label is limited to 8 printable characters per label line.

**INVALID KEYNAME: \_ \_ \_ (U)**

The specified key name is not allowed.

**Related Assemblies**

A16 processor/video assembly.

**Troubleshooting Hints**

The key name may have conflicted with an analyzer programming command. To avoid this problem, use an underscore as the second character in the key name, or avoid beginning the key name with the following pairs of letters: LB, OA, OL, TA, TB, TR, MA, MF, TS, OT, and DR.

**INVALID OUTPUT FORMAT (U)**

The output format is not valid. See the appropriate programming command description to determine the correct format.

**INVALID RANGE: Stop < Start (U)**

Indicates that the first trace element specified for a range of trace elements is larger than ending trace element. When specifying a trace range, the starting element must be less than the ending element. For example, TRA[2,300] is legal but TRA[300,2] is not.

**INVALID REGISTER NUMBER (U)**

The specified trace register number is invalid.

**INVALID REPEAT MEM OVFL (U)**

Memory overflow occurred due to a REPEAT routine. This can occur if there is not enough analyzer memory for the REPEAT UNTIL declaration, or if the REPEAT UNTIL declaration exceeds 2047 characters.

**INVALID REPEAT NEST LEVEL (U)**

The nesting level in the REPEAT routine is improperly constructed. This can occur if too many REPEAT routines are nested. When used within a downloadable program (DLP), the maximum number of REPEAT UNTIL statements that can be nested is 20.

### **INVALID RS-232 ADRS/OPERATION (U)**

An RS-232 operation was aborted due to an invalid operation.

#### **Related Assemblies**

A16 processor/video assembly.

#### **Troubleshooting Hints**

Reset all instruments attached to the bus.

### **INVALID SAVE REG (U)**

Data has not been saved in the specified state or trace register, or the data is corrupt.

### **INVALID SCRMOVE (H)**

Indicates the analyzer may have a hardware failure.

#### **Related Assemblies**

All internal assemblies.

#### **Troubleshooting Hints**

Remove instrument from bus. Perform an instrument preset.

### **INVALID START INDEX (U)**

Indicates that the first trace element specified for a range of trace elements is not within the trace range of the specified trace.

### **INVALID STOP INDEX (U)**

Indicates that the ending trace element specified for a range of trace elements is not within the trace range of the specified trace.

### **INVALID STORE DEST: \_ \_ \_ (U)**

The specified destination field is invalid.

## Memory Overflow: ERASE DLP MEM and reload (U)

This message indicates that too many user-defined items (functions, variables, key definitions), or downloadable programs have been loaded into analyzer memory.

### Related Assemblies

A16 processor/video assembly.

### Troubleshooting Hints

Use **DISPOSE USER MEM** and then load the user-defined item or downloadable program into analyzer memory.

Press the following analyzer keys.

**CONFIG** More 1 of 3

**DISPOSE USER MEM**

If the above keys are not accessible perform the following steps.

1. Press the following analyzer keys.

**DISPLAY**

**Change Title**

Use the knob to select the letters **DISPOSE ALL;**, be sure to include the semicolon (;).

2. Press the following analyzer keys.

**CAL** More 1 of 4 More 2 of 4

**SERVICE CAL**

**EXECUTE TITLE**

If the analyzer still appears to be locked up, refer to “Troubleshooting the A16 Processor/Video Board Assembly” in Chapter 4.

## INVALID TRACE: \_ \_ \_ (U)

The specified trace is invalid.

## INVALID TRACE NAME: \_ \_ \_ (U)

The specified trace name is not allowed. Use an underscore as the second character in the trace name, or avoid beginning the trace name with the following pairs of letters: LB, OA, OL, TA, TB, TR, MA, MF, TS, OT, and DR.

## INVALID TRACENAME: \_ \_ \_ (U)

Indicates the specified trace could not be saved because the trace name is not allowed. To avoid this problem, use an underscore as the second character in the trace name, or avoid beginning the trace name with the following pairs of letters: LB, OA, OL, TA, TB, TR, MA, MF, TS, OT, and DR.

**INVALID VALUE PARAMETER: - - - (U)**

The specified value parameter is invalid.

**INVALID VARDEF: - - - (U)**

The specified variable name is not allowed. To avoid this problem, use an underscore as the second character in the variable label, or avoid beginning the variable label with the following pairs of letters: LB, OA, OL, TA, TB, TR, MA, MF, TS, OT, and DR.

**INVALID WINDOW TYPE: - - - (U)**

The specified window is invalid. See the description for the TWINDOW programming command.

**LOST SIGNAL (U)**

For the HP 8592L, HP 8593E, or HP 8596E, this message indicates that the cable from the 100 MHz COMB OUT connector to the analyzer input is defective or has become disconnected during the CAL YTF routine. For the HP 8595E, this message indicates that the cable from the CAL OUT connector is defective or has been disconnected during the CAL YTF routine. Be sure to use a short, low-loss cable to connect the signal to the analyzer input when performing the CAL YTF routine.

**Related Assemblies**

A7 analog interface board.

**Troubleshooting Hints**

Concentrate on the RF control sections of the A7 analog interface board.

**LO UNLVL (U)(H)**

Indicates that the analyzer local oscillator distribution amplifier is not functioning properly. This message may appear on the HP 8592L, HP 8593E, HP 8594E, HP 8595E, and HP 8596E with Options 009/010, Option 009, or Option 010.

**Related Assemblies**

A10 LO distribution amplifier (LODA) control/tracking generator control.

**Troubleshooting Hints**

Check the LO<sub>sense</sub> and gate bias adjustments on A10. Bias voltages are marked on a label on the top of the high frequency RF.

### **Marker Count Reduce SPAN (U)**

Indicates the resolution bandwidth to span ratio is too small to use the marker count function. Check the span and resolution bandwidth settings.

### **Marker Count Widen RES BW (U)**

Indicates that the current resolution bandwidth setting is too narrow to use with the marker counter function. The marker counter function can be in narrow resolution bandwidths (bandwidths that are less than 1 kHz) with the following procedure.

1. Place the marker on the desired signal.
2. Increase the resolution bandwidth to 1 kHz and verify the marker is on the signal peak.
3. If the marker is on the signal peak, the marker count function can be used in either the 1 kHz resolution bandwidth or the original narrow resolution bandwidth setting. If the marker is not on the signal peak, it should be moved to the signal peak and the marker counter function should not be used with a resolution bandwidth setting of less than 1 kHz.

### **MEAS UNCAL (U)**

The measurement is uncalibrated. Check the sweep time, span, and bandwidth settings, or press **AUTO COUPLE**, **AUTO ALL**.

### **No card found (U)**

Indicates that the memory card is not inserted.

### **No points defined (U)**

Indicates the specified limit line or amplitude correction function cannot be performed because no limit line segments or amplitude correction factors have been defined.

## MIXER BIAS CAL FAILED

This message applies to HP 8592L, 8593E, 8595E, and 8596E spectrum analyzers only.

During the **CAL MXR** routine, the comb signal was not found at the displayed center frequency.

### Related Assemblies

A3A1 comb generator, A3A11 step-recovery diode, A3A12 3dB attenuator, J2 connector.

### Troubleshooting Hints

- Make sure that the 100 MHz COMB OUT is connected to the analyzer input using the comb generator cable (SMA to Type N) supplied with the analyzer. (A comb generator cable (SMA to SMA) is supplied with Option 026 instruments.)
- Perform the following steps to verify the comb-generator output manually.
  1. Press the following keys.

**PRESET**

**FREQUENCY** 100 **MHz**

**SPAN** 500 **MHz**

2. Look for the 100 MHz comb-generator signal to the right of the local oscillator signal. When **COMB GEN ON OFF** is OFF, this signal has an amplitude of approximately  $-8$  dBm and the 100 MHz harmonics are less than  $-20$  dBc.
3. Press the following keys.

**AUX CTRL**

**COMB GEN ON OFF** (On)

4. When the comb-generator output amplifier is enabled, the amplitude of the 100 MHz signal and the 100 MHz harmonics increase. The 100 MHz signal amplitude increases to approximately  $+12$  dBm.
  - If the signal amplitude does not increase, check that the comb-generator control line from the A7 analog interface assembly is switching correctly.  
Refer to Foldout 9-2, 9-3, or 9-4, RF Section Overall Block Diagram for your analyzer, for more information about the comb-generator control voltage values.
  - If the A7 control line is correct, suspect the A3A11 step-recovery diode or the A3A1 comb generator.

Refer to Foldout 9-2, 9-3, or 9-4, RF Section Overall Block Diagram for your analyzer, for more information.

## **OVEN COLD (M)**

This message is displayed for instruments equipped with Option 004, precision frequency reference.

The message is displayed for 5 minutes after the instrument is turned on. The message alerts the user that the oven in the A22 precision frequency reference has not been on long enough to warm the reference to its operating temperature.

### **Related Assemblies**

A22 precision frequency reference.

### **Troubleshooting Hints**

This is a timed message that comes on whenever the instrument is turned on; the temperature of the A22 precision frequency reference oven-controlled crystal oscillator (OCXO) is not measured.

The instrument firmware displays the message only when it senses that the A22 assembly is connected to its power supply through W15, the OCXO power cable. If the message does not appear, check the W15 cable.

## **PARAMETER ERROR: \_ \_ \_ (U)**

The specified parameter is not recognized by the analyzer. See the appropriate programming command description to determine the correct parameters.

## **PASSCODE NEEDED (U)**

Indicates that the function cannot be accessed without the pass code.

## **POS-PK FAIL (H)**

The positive-peak-detector check has failed during the confidence test routine, **CONF TEST**. The level of the noise floor for the positive-peak detector is statistically compared to that of the sample detector. The mean of the data from the positive-peak detector should be greater than the mean of the data from the sample detector.

### **Related Assemblies**

A16 processor/video assembly.

### **Troubleshooting Hints**

This test performs a functional check of switching for the positive-peak detector on the A16 processor/video assembly.

Refer to the **CONF TEST** description in Chapter 13 for more information about the confidence test routine.



## REF UNLOCK (M)(H)

The oscillator on the A9 third converter is not locked to a 10 MHz frequency reference. The analyzer must be connected to one of the following frequency references.

- 10 MHz standard timebase. The reference is a room-temperature crystal oscillator (RTXO) that is located on the A25 assembly.
- Precision frequency reference. The reference is a oven-controlled crystal oscillator (OCXO).
- External 10 MHz frequency reference.

### Related Assemblies

A22 precision frequency reference, standard 10 MHz reference, A25 counter lock.

### Troubleshooting Hints

Refer to Foldout 9-2, 9-3, or 9-4, RF Section Overall Block Diagram for your analyzer, for more information.

1. Check the rear-panel cable connections for the 10 MHz reference.

When using either the standard 10 MHz timebase or the precision frequency reference, make sure that the 10 MHz REF OUT on the rear panel is connected to the EXT REF IN. The W6 jumper is supplied with the analyzer for this purpose.

When using an external 10 MHz reference, make sure it is connected to the EXT REF IN on the rear panel.

2. If the rear panel connection is correct, check the power output of the 10 MHz frequency reference.
  - The A22 standard 10 MHz timebase (RTXO) has a typical output of  $0 \text{ dBm} \pm 6 \text{ dB}$ .
  - A22 precision frequency reference (OCXO), has a typical output of  $0 \text{ dBm} \pm 3 \text{ dB}$ .
  - An external 10 MHz reference should have an output between  $-2 \text{ dBm}$  and  $+10 \text{ dBm}$ .
3. If the output of the 10 MHz reference is correct, check the continuity of W18, the EXT REF IN cable, and W17, the 10 MHz OUT cable.
4. Check the continuity of the VTO\_TUNE control line.
5. Check the continuity of the W14 ribbon cable and the W21 coaxial cable.
6. Check the continuity of the A25 assembly connections to the A9 assembly that pass through the A15 motherboard.
7. If the error message is still present, suspect the A25 counter lock assembly.

### **Require 1 signal > PEAK EXCURSION above THRESHOLD (U)**

Indicates that the N dB PTS routine cannot locate a signal that is high enough to measure. The signal must be greater than the peak excursion above the threshold level to measure.

### **Require 3 signals > PEAK EXCURSION above THRESHOLD (U)**

Indicates that the % AM routine cannot locate three signals that are high enough to measure. The signals must be greater than the peak excursion above the threshold level to measure.

### **Require 4 signals > PEAK EXCURSION above THRESHOLD (U)**

Indicates that the TOI routine cannot locate four signals that are high enough to measure. The signals must be greater than the peak excursion above the threshold level to measure.

### **Required option not installed (U)**

Some analyzer functions require that an option be installed in the analyzer. See the description for the function in the *HP 8590 E-Series and L-Series Spectrum Analyzers User's Guide* for more information about which option is required.

### **RES-BW NOISE FAIL (H)**

During the confidence test routine, **CONF TEST**, the noise floor level was too high for the indicated resolution bandwidth.

Starting with the widest resolution bandwidth, the test compares the noise floor amplitude of each bandwidth to the noise floor amplitude of the next, narrower resolution bandwidth. If a decrease in noise-floor amplitude does not occur, the test displays the narrower bandwidth as a test failure.

### **Related Assemblies**

A11 bandwidth filter, A13 bandwidth filter.

### **Troubleshooting Hints**

Refer to the **CONF TEST** description in Chapter 13 for more information about the confidence test routine.

- A high noise floor can be caused by a defective bandwidth control line.  
Look for a change in noise floor level and bandwidth when manually switching between bandwidths. If no change occurs, check the bandwidth control lines from the A7 analog interface assembly.  
Refer to Foldout 9-1, IF/Control Overall Block Diagram, and bandwidth control line information in Chapter 5 for further information.
- A high noise floor can also be caused by loose screws in the IF assembly section. Make sure the IF assembly cover screws are properly tightened.

## RES-BW SHAPE FAIL (H)

During the confidence test routine, **CONF TEST**, the 3 dB bandwidth of a resolution bandwidth was not within 20% of its nominal value. The 10 kHz, 30 kHz, 100 kHz, 300 kHz, 1 MHz, and 3 MHz bandwidths are checked and the bandwidths that fail are displayed.

### Related Assemblies

A7 analog interface, A11 bandwidth filter, A13 bandwidth filter.

### Troubleshooting Hints

- The bandwidth of the failed resolution bandwidths may have drifted since the last time the self-calibration routines were run. The **CAL AMPTD** self-calibration routine corrects for bandwidth error.

If a bandwidth drifts out of tolerance soon after performing **CAL AMPTD**, a bandwidth-filter assembly or bandwidth control line may be unstable.

1. Check the 3 dB bandwidth of the failed resolution bandwidths using the **3 dB POINTS** softkey.
2. Use **DISPLAY CAL DATA** to view the current bandwidth control factors.
3. Perform the **CAL AMPTD** self-calibration routine. Use **DISPLAY CAL DATA** to monitor changes in the bandwidth control factors each time the **CAL AMPTD** routine is performed.
4. Repeat the **CONF TEST** routine. If the error message is still present, look for an unstable bandwidth-filter assembly or bandwidth control line.

Refer to bandwidth control line information in Chapter 5 when troubleshooting the bandwidth control lines.

- The bandpass shape of the failed resolution bandwidths may have drifted since the last time the self-calibration routines were run.
  1. Look at the bandpass shape of each failed bandwidth. If realignment is needed, refer to the crystal and LC bandwidth filter adjustment procedure in Chapter 2.
  2. Run the **CAL AMPTD** self-calibration routine and store the data using **CAL STORE**.
  3. Repeat the **CONF TEST** routine. If the error message is still present, one of the bandwidth-filter assemblies may be defective.

Refer to the **CONF TEST** description in Chapter 13 for more information about the confidence test routine.

## **RF PRESEL ERROR (H)**

Indicates that the preselector peak routine cannot be performed.  
For HP 8592L, 8593E, 8595E, and 8596E spectrum analyzers only.

### **Related Assemblies**

A7 analog interface assembly, A3A8 (switched) YIG-tuned filter.

### **Troubleshooting Hints**

Ensure that the signal source is connected to the RF input.

## **RF PRESEL TIMEOUT (H)**

Indicates that the preselector peak routine cannot be performed.

### **Related Assemblies**

A7 analog interface assembly, A3A8 (switched) YIG-tuned filter.

### **Troubleshooting Hints**

Ensure that the signal source is connected to the RF input.

## **SAMPLE FAIL (H)**

During the confidence test routine, **CONF TEST**, the sample-detector test, has failed. The test makes a statistical comparison between the peak-to-peak amplitude of the noise floor for the positive-peak detector and the noise floor for the sample detector.

The error message is displayed if the standard deviation of the data for the sample detector is less than the standard deviation of data for the positive-peak detector.

### **Related Assemblies**

A16 processor/video assembly.

### **Troubleshooting Hints**

This test performs a functional check of switching for the sample detector on the A16 processor/video assembly.

Refer to the **CONF TEST** description in Chapter 13 for more information about the confidence test routine.

## **SETUP ERROR (U)**

Indicates that the span, channel bandwidth, or channel spacing are not set correctly for the adjacent channel power or channel power measurement.

## **SIGNAL CLIPPED (U)**

Indicates that the current FFT measurement sweep resulted in a trace that is above the top graticule line on the analyzer display. If this happens, the input trace (trace A) has been “clipped,” and the FFT data is not valid.

## **Signals do not fit expected % AM pattern (U)**

Indicates that the % AM routine cannot perform the percent AM measurement because the on-screen signals do not have the characteristics of a carrier with two sidebands.

## **Signals do not fit expected TOI pattern (U)**

Indicates that the TOI routine cannot perform the third-order intermodulation measurement because the on-screen signals do not have the characteristics of two signals and two distortion products.

## **SMPLR UNLCK (U)(H)**

Indicates that the sampling oscillator circuitry is not functioning properly.

### **Related Assemblies**

HP 8591E and HP 8590L spectrum analyzers and HP 8591C cable TV analyzers only:  
A6 YTO, A25 counter lock board assembly.

All other HP 8590 E-Series and L-Series spectrum analyzers and HP 8591C cable TV analyzers:  
A3A7 YTO, A25 counter lock board assembly.

### **Troubleshooting Hints**

Check that the external frequency reference is correctly connected to the EXT REF INPUT. Observe the frequency diagnostics. Look for numbers that are out of tolerance.

## **SOFTKEY OVFL (U)**

Softkey nesting exceeds the maximum number of levels.

## **SRQ \_ \_ \_ (M)**

The specified service request is active. Service requests are a form of informational message and are explained in Appendix A of the *HP 8590 E-Series and L-Series Spectrum Analyzers User's Guide*.

## **STEP GAIN/ATTEN FAIL (H)**

During the confidence test routine, `CONF TEST`, the step-gain switching check, has failed. Looking at displayed noise, the test steps the reference level from  $-60$  dBm to  $+30$  dBm, in 10 dB increments, with the input attenuator set to 60 dB. The error message is displayed if the noise level does not increase for each 10 dB step in reference level.

### **Related Assemblies**

A12 amplitude control.

### **Troubleshooting Hints**

The confidence test performs a functional check of the A12 assembly step gains; it does not check the function of the A12 step attenuators. The test passes if it detects any increase in noise floor level for each 10 dB change in reference level.

There is no manual adjustment for the 10 dB step gains. The `CAL AMPTD` self-calibration routine corrects for the 10 dB step gains and input attenuator errors. Refer to the `CAL AMPTD` description in Chapter 13 for more information.

If one of the 10 dB step gains appears to be faulty, check the step-gain control lines from the A7 analog interface assembly.

Refer to “Troubleshooting the A15 Motherboard Assembly” in Chapter 5 for the location of the step gain control lines.

If the control lines function correctly, suspect a A12 amplitude control assembly failure.

Refer to the IF section gain control information in Chapter 5 for further information about the operation of the 10 dB step gains.

Refer to the `CONF TEST` description in Chapter 13 for more information about the confidence test routine.

## **Stop at marker not available with negative detection (U)**

Indicates that the marker counter cannot be used when negative peak detection is selected. To use the marker counter, turn off negative peak detection with `DETECTOR PK SP NG`.

## **SYMTAB EMPTY (U)**

Indicates that the user-defined items (user-defined functions, user-defined variables, user-defined traces, user-defined softkeys) and any personalities (for example, the HP 85716A CATV System Monitor Personality) in the analyzer memory have been deleted.

### **Related Assemblies**

A16 processor/video assembly.

### **Troubleshooting Hints**

Use `DISPOSE USER MEM` to clear analyzer memory. Perform instrument calibrations. If the message is still displayed, it may indicate a hardware failure.

## TABLE FULL (U)

Indicates the upper or lower table of limit lines contains the maximum number of entries allowed. Additional entries to the table are ignored.

## TG SIGNAL NOT FOUND (U)

This error message applies to analyzers equipped with Option 010, 50  $\Omega$  Output Tracking Generator, and Option 011, 75  $\Omega$  Output Tracking Generator.

### Description

During the CAL TRK GEN self-calibration routine, a signal response above the first division from bottom screen is not present. The primary purpose of the error message is to indicate that the CAL cable is not connected from the tracking generator RF OUT to the RF INPUT.

### Related Assemblies

A7A1 tracking control, A24 FL1, A24A1 tripler, A24A2 tracking converter, A24A3 amplifier detector, A24A4 output attenuator.

### Troubleshooting Hints

- If a low signal response is present within the first division from bottom screen, check the cable connection from the RF OUT to the RF INPUT.

A cable with excessive loss can cause a low-level signal. Use the CAL cable that is supplied with the instrument. Be sure to use the same CAL cable when performing all the self-calibration routines.

Refer to Table 1-4 for the part number of the CAL cable.

- If no signal response is present, check the output of the tracking generator at the RF OUT connector. Refer to Foldout 9-5, Tracking Generator Block Diagram, in Chapter 9 for more information.

## TG UNLVL (U)(H)

This message can indicate the following: that the source power is set higher or lower than the analyzer can provide, that the frequency span extends beyond the specified frequency range of the tracking generator, or that the calibration data for the tracking generator is incorrect. See the *HP 8590 E-Series and L-Series Spectrum Analyzers User's Guide* for more information.

### Related Assemblies

HP 8590L and HP 8591E spectrum analyzers only:

A7A1 tracking generator control assembly, A24 tracking generator control assembly.

### Troubleshooting Hints

Perform the tracking generator control routine.

### **Too many signals with valid N dB points (U)**

Indicates the N dB PTS function has located two or more signals that have amplitudes within the specified dB from the signal peak. If this happens, you should decrease the span of the analyzer so that only the signal that you want to measure is displayed.

### **Trace A is not available (U)**

Indicates that trace A is in the store-blank mode and cannot be used for limit-line testing. Use **CLEAR WRITE A** or **VIEW A** to change trace A from the store-blank mode to the clear write mode, and then turn on limit-line testing.

### **UNDF KEY (U)**

The softkey number is not recognized by the analyzer.

### **USING DEFAULTS: \_ \_ \_**

The analyzer has determined that the contents of certain RAM locations are not within the expected values. The number following the colon corresponds to the location that caused the default condition. This number was used during the initial design and is not applicable to troubleshooting.

### **Related Assemblies**

A16 processor/video assembly.

### **Troubleshooting Hints**

This message may indicate that the battery used to power the RAM is dead. Refer to restoring analyzer memory.

### **USING DEFAULTS self cal needed (U)**

Indicates that the current correction factors are the default correction factors and that the CAL FREQ & AMPTD routine needs to be performed. For the HP 8592L, HP 8593E, HP 8595E, or HP 8596E, the CAL YTF routine is also required.

### **Verify gate trigger input is disconnected before CAL AMPTD (U)**

This message is meant to remind you that nothing should be connected to the GATE TRIGGER INPUT connector on the analyzer rear panel during the CAL AMPTD routine.



## **VID-BW FAIL (H)**

During the **CONF TEST** routine, the video bandwidth check has failed. The test checks for a decrease in the peak-to-peak excursion of the noise trace as the video bandwidth is decreased.

### **Related Assemblies**

A14 log amplifier/detector, A16 processor/video assembly.

### **Troubleshooting Hints**

The **CONF TEST** routine performs a functional check of switching for the video bandwidth circuitry on the A16 processor/video assembly.

Refer to **CONF TEST** description in Chapter 13 for more information about the confidence test routine.

Problems with the low-pass filter on the A14 log amplifier/detector assembly can cause the video bandwidths to appear to be incorrect.

## **Waiting for gate input ... (U)**

Indicates that the analyzer needs an external trigger signal to use the time-gating functions.

### **Related Assemblies**

A16 processor/video assembly, A105 gated video board assembly.

### **Troubleshooting Hints**

Before using the time-gating functions, ensure there is a trigger pulse connected to the GATE TRIGGER INPUT connector on the rear panel of analyzer and that the GATE OUTPUT is connected to the EXT TRIG INPUT connector. If the connections are correct and, after an instrument preset, the error message is still displayed, the internal triggering circuitry on the A16 processor/video assembly may not be functioning correctly. If you do not want to use the time-gating functions, press **PRESET**.

## **YTF is not available (U)**

The YTF is only available for the HP 8592L, HP 8593E, HP 8595E, and HP 8596E.

## Service Equipment and Tools

---

This chapter contains information about service equipment and tools needed to perform analyzer calibration, adjustments, and troubleshooting.

---

### Static-Safe Accessories

Electrostatic discharge (ESD) can damage or destroy electronic components. All work performed on assemblies containing electronic components should be done *only* at a static-safe workstation.

Table 15-1 provides information on ordering static-safe accessories and shows an example of a static-safe workstation using two types of ESD protection.

- Conductive table-mat and wrist-strap combination.
- Conductive floor-mat and heel-strap combination.

The two types must be used together to ensure adequate ESD protection.

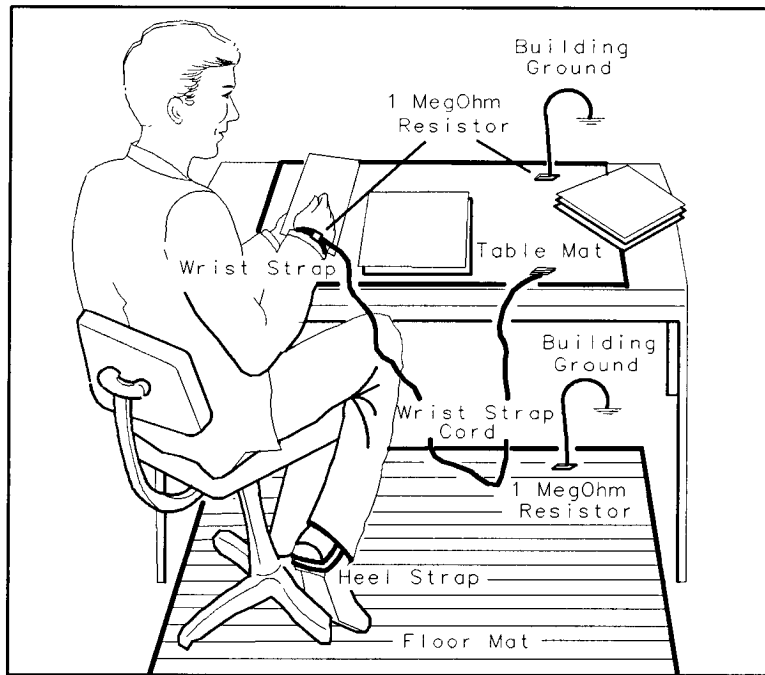
---

**Warning**      **These techniques for a static-safe workstation should not be used when working on circuitry that has a voltage potential greater than 500 volts.**

---

For more information about preventing ESD damage, contact the Electrical Overstress/Electrostatic Discharge (EOS/ESD) Association, Inc. The ESD standards developed by this agency are sanctioned by the American National Standards Institute (ANSI).

**Table 15-1. Static-Safe Accessories**



FORMAT46

HP Part Number	Description
9300-0797	Set includes: 3M static control mat 0.6 m x 1.2 m (2 ft x 4 ft) and 4.6 m (15 ft) ground wire. (The wrist-strap and wrist-strap cord are not included. They must be ordered separately.)
9300-0980	Wrist-strap cord 1.5 m (5 ft)
9300-1383	Wrist-strap, color black, stainless steel, without cord, has four adjustable links and a 7 mm post-type connection.
9300-1169	ESD heel-strap (reusable 6 to 12 months).

## Recommended Test Equipment

Refer to the calibration guide for your analyzer for a list of equipment required to perform the performance test, adjustments, and troubleshooting.

## Recommended Service Tools

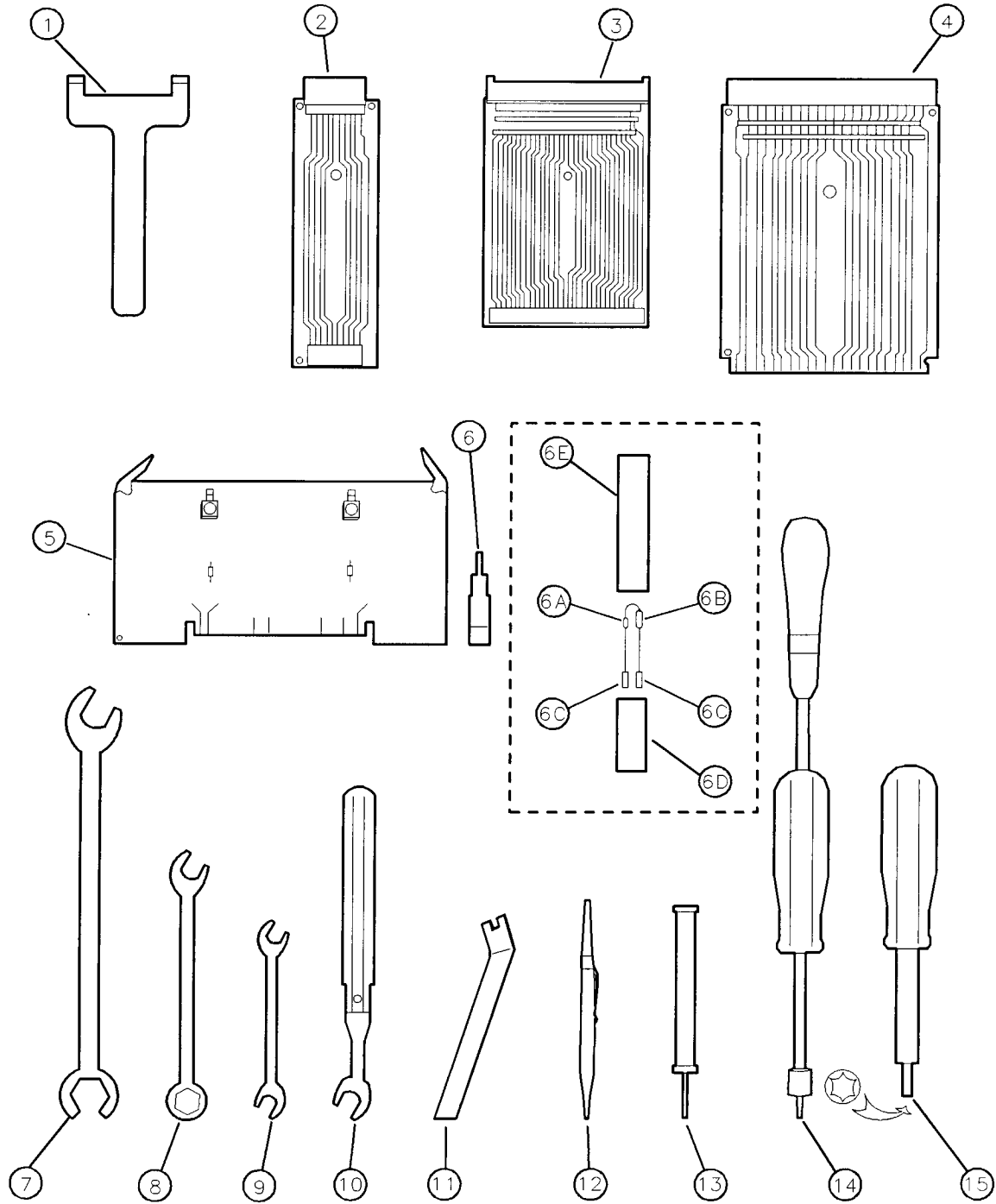
Table 15-2 and Figure 15-1 provide descriptions and HP part numbers for special service tools that are used throughout this manual.

Table 15-3 provides an additional list of common hand tools that are also recommended for repairing the HP 8590 D-Series and E-Series spectrum analyzers, HP 8591C cable TV analyzers, and HP 8594Qs.

Refer to "Ordering Information" in Chapter 12 when ordering service tools and accessories.

**Table 15-2. Special Service Tools**

Item	Description	HP Part Number	Use*
1	Board puller, two prongs to lift PC boards	03950-4001	A,T
2	Extender board, pin and socket, 20 contacts (two required)	5062-1999	T
3	Extender board, pin and socket, 60 contacts	5062-2000	T
4	Extender board, 22 pin edge connector, 44 contacts	08565-60107	T
5	Injector board	5062-6421	A,T
6	Crystal bandwidth shorts (set of three)	5062-4855	A,T
	<i>Components Needed to Build One Crystal Short</i>		
6a	0.01 $\mu$ F capacitor	0160-4832	
6b	90.0 $\Omega$ resistor	0757-0400	
6c	Square, single-connector terminal (two required)	1251-4182	
6d	Two-terminal connector body	1251-0689	
6e	3/16 inch dia. heat shrink tubing, 1 1/8 inches long	0890-0029	
7	Combination wrench, 5/16 inch, with slotted box end (two required)	08555-20097	A,R
8	Combination wrench, 1/4 inch	8720-0014	R
9	Open end wrench, 15/64 inch, open end	8710-0946	R
10	Torque wrench, break-away, 10 inch-pounds, 5/16 inch, open end	40-60271 †	R
11	Cable puller, pry-bar style	5021-6773	A,T,R
12	Alignment tool, metal tip, plastic body	8710-0630	A,T
13	Alignment tool, nonmetallic tip, fiber body	8710-0033	A,T
14	Alignment tool		A,T
15	TORX hand driver with required T8 and T10 bits, included in TORX driver kit with multiple bits (See tool-tip illustration)	8710-1426	A,R
<p>*A = Adjustment, T = Troubleshooting, R = Replacement Procedure</p> <p>† The part number provided is a non-HP part number. This tool can be ordered from:            Assembly Systems Inc.            16595 Englewood Avenue            Los Gatos, California 95032            (408) 395-5313</p> <p>If you order a similar tool from your local supplier, it is important that the outside dimension of the wrench be no wider than 0.518 inches. This allows the wrench to be used on semirigid cable connectors in confined areas.</p>			



FORMAT94

**Figure 15-1. Special Service Tools**

**Table 15-3. Required Common Hand Tools**

Description	HP Part Number	Use*
Hex (Allen) wrench, 3mm	8710-1392	R
Hex (Allen) wrench, 4mm	8710-1755	A,R
Hex (Allen) wrench, no. 4	5020-0288	R
Hex (Allen) wrench, no. 6	5020-0289	R
Nut driver, 7mm	8710-1217	R
Nut driver, 3/8 inch	8720-0005	R
Nut driver, 5/16 inch	8720-0003	R
Nut driver, 7/16 inch	8720-0006	R
Nut driver, 9/16 inch, drilled out, end covered with heatshrink tubing to protect front/rear-panel surface	8720-0008	R
Phillips Screwdriver, small no. 0	8710-0978	R
Poizidriv screwdriver, small no. 1	8710-0899	A,R
Poizidriv screwdriver, large no. 2	8710-0900	A,R
Long-nose pliers	8710-0003	R
Wire cutters	8710-0012	R
Wire strippers	8710-0058	R
* A = Adjustment, R = Replacement Procedure		